



## 1 Company Profile



► 3

## 1 New products



► 11

## 2 Position switches for heavy duty applications



FD series

► 15

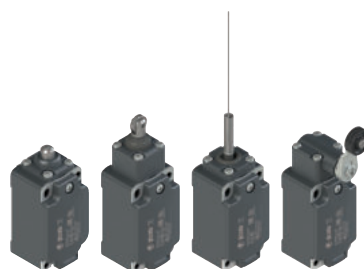

FP series

► 25



FL series

► 35



FC series

► 45

## 3 Position switches with and without reset for standard applications

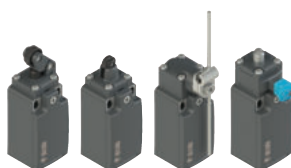

FR series

► 55



FM series

► 67

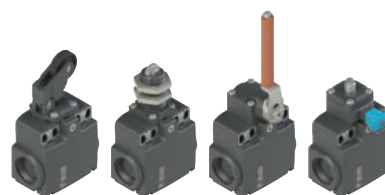

FX series

► 79



FZ series

► 91



FK series

► 103

**4 Modular pre-wired position switches**

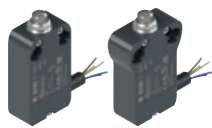

NA-NB series

► 115



NF series

► 125

**5 Microswitches**



MK series

► 141



MS-MF series

► 151

**6 Switches for special applications**



Switches compliant with ATEX directive

► 157

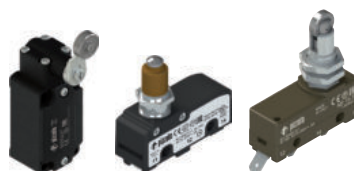

Switches for high temperatures

► 185



Electronic contact block

► 195



Position switches with open design

► 197



Position switches for special applications

► 199



Switches with external parts in stainless steel

► 201

**Devices for lifts**



The dedicated catalogue is available.

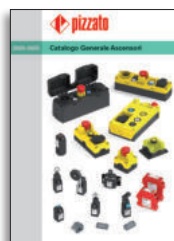

**7 Accessories**



► 207

**8 Appendix**

- Utilization requirements ► 227
- Contact blocks ► 243
- Assembled connectors ► 255
- Introduction to safety engineering ► 257
- Technical definitions ► 283
- General terms and conditions of sale ► 290



## MORE THAN 300 PROFESSIONALS WITH PASSION

It is people, with their professionalism and dedication that make a great company. This profound conviction has always guided Pizzato Elettrica in their choice of employees and partners.

Today, Giuseppe and Marco Pizzato lead a tireless team providing the fastest and most efficient response to the demands of the market. This team has grown over the last 10 years and has achieved a considerable increase in sales in all the countries where Pizzato Elettrica is present.

The various strategic sectors of the business are headed by professionals with significant experience and expertise. Many of these people have developed over years with the company.



Others are experts in their specific field and have integrated personal experience with the Pizzato Elettrica ethos to extend the company's capability and knowledge.

From the design office to the technical assistance department, from managers to workers, every employee believes in the company and its future. Pizzato Elettrica employees all give the best of themselves secure in the knowledge they are the fundamental elements of a highly valuable enterprise.



## 100% MADE IN ITALY

Pizzato Elettrica is one of the leading European manufacturers of position switches, microswitches, safety devices, safety modules, foot switches, control and signalling devices, and devices for lifts. An entrepreneurial company such as Pizzato Elettrica bases its foundations on a solid and widely shared value system. The pillars that form the basis of the company's work have remained constant, and constitute the fundamental guiding principles for all company activities.

### PASSION FOR QUALITY

Passion for product quality, orientation towards excellence, innovation, and continuous development, represent the key principles of Pizzato Elettrica's everyday work.

Anyone using Pizzato Elettrica's products does so in the certainty that these devices are of certified quality, since they are the result of a process that is scrupulously controlled at every stage of the production.

The company's goal is to offer the market safe, reliable, and innovative solutions.

### CARE FOR THE CUSTOMER

In order to be successful, a product must respond to the specific needs of those who will use it. Market developments must be carefully monitored in order to understand, in advance, which new applications will prove themselves truly useful. This is why Pizzato Elettrica has always cultivated close synergies with the companies that have chosen it

as a supplier, using this continuous dialogue to identify the potential developments of the own product range in order to make it highly flexible, complete and capable to respond to the most diverse needs.

### 100% MADE IN ITALY

All Pizzato Elettrica products are designed, developed, and tested entirely at the company plants in Marostica, in the province of Vicenza in Italy. The company is thus able to meet specific customer requirements at all times, by offering a comprehensive range of products and technologically advanced solutions.

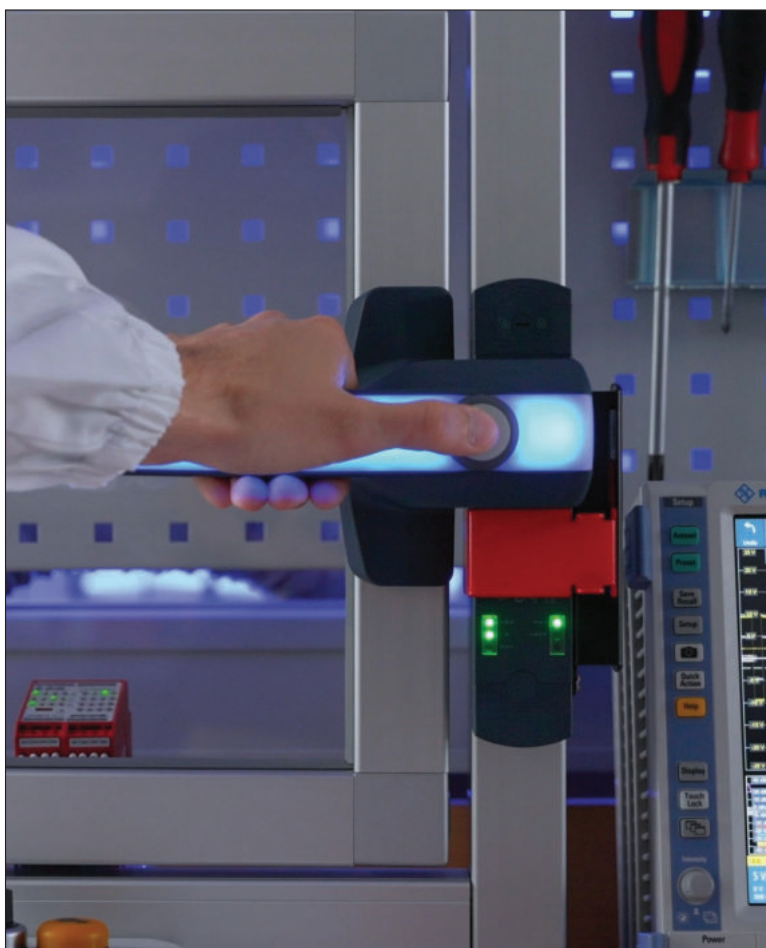



## 1984: AN ENTREPRENEURIAL STORY BEGINS

- 1984** The company Pizzato di Pizzato B. & C. snc. manufacturer of position switches is founded.
- 1988** The company becomes a limited liability partnership, and is renamed Pizzato Elettrica, a brand shortly destined to become renowned and valued nationwide. The first company-owned plant (P1) geared towards mechanical processing was built.
- 1990** By the end of the decade, thanks to the development of quality products and the experience built on the Italian market, Pizzato Elettrica turns to the international market.
- 1995** Building of the second plant (P3) geared towards the moulding of plastic materials. Development of the position switch range continues in parallel. Start of significant years in terms of safety devices planning. The safety sector becomes a key sector to the company.
- 1998** Construction of the third plant (P4), housing the assembly department.
- 2002** Achievement of the ISO 9001:2000 certification. Launching of the first safety modules. The new factory headquarters and logistics centre (P5) is built and will remain the company's headquarters for many years. Continued expansion of the industrial safety and automation product range.
- 2007** Pizzato Elettrica faces its first generational change: Giuseppe and Marco Pizzato take over the company directorship.
- 2010** Extension of Pizzato Elettrica product portfolio, with the launch of the innovative EROUND line consisting of control and signalling devices. This product range accompanies position switches and safety devices, thus offering complete solutions to customers.
- 2012** Introduction of Gemnis Studio, the first software produced by Pizzato Elettrica. A graphic development environment for the creation, simulation, and debugging of programs that can be integrated in the Gemnis line modules.
- 2013** Foundation of first subsidiary of Pizzato Elettrica, Pizzato Deutschland GmbH, in Germany.
- 2014** A new production facility (P8) dedicated to switches and automatic machines is opened, spanning a surface area of 6000 m<sup>2</sup>.
- 2016** The new NS series of safety switches with electromagnets and RFID technology is introduced, fruit of the company's experience, spanning more than thirty years in the field of industrial safety. To date it is the state of the art in its industry. Foundation of second subsidiary of Pizzato Elettrica, Pizzato France SARL, in France.
- 2017** The company continues to expand and achieves the quality certification based on the more recent version of standard ISO 9001 of 2015. In Spain, the third Pizzato Elettrica subsidiary is founded: Pizzato Iberica SL. The foundation stone is laid for the new factory (P6), which is to become the company's headquarters.
- 2018** The safety handle P-KUBE Krome is launched, a brand new product in the market, confirming that Pizzato Elettrica thrives on innovation in the sectors of automation and industrial safety. Foundation of fourth subsidiary of Pizzato Elettrica, Pizzato USA Inc, in the United States.
- 2019** The new factory (P6) is opened, a modern building of 28,000 m<sup>2</sup> realized with the most advanced Industry 4.0 technologies, where all offices and production divisions are transferred, allowing to further improve the flow of material and information. The logistics and shipment department is optimised with the introduction of a new completely automated warehouse.
- 2021** Pizzato Elettrica India Ltd. and Pizzato Korea Ltd., commercial branches of Pizzato Elettrica, are established in India and South Korea, respectively.
- 2022** Foundation of Pizzato Academy, Pizzato Elettrica's new training site for getting better acquainted with our products and following the constant regulatory developments in the sector.
- Today**, Giuseppe and Marco Pizzato lead a company in constant growth in terms of new product launches, number of employees, turnover, and new markets. Pizzato Elettrica is continuing its new product internationalisation and development process.



## 100 MILLION PARTS SOLD WORLDWIDE

Pizzato Elettrica's product catalogue contains more than 10,000 articles, with more than 1,500 special codes developed for devices personalised according to clients' specific needs. Pizzato Elettrica devices can be grouped, according to typology, into three main macro-categories.

### POSITION SWITCHES

Pizzato Elettrica position switches are daily installed in every type of industrial machinery all over the world for applications in the sector of wood, metal, plastic, automotive, packaging, lifting, medicinal, naval, etc.

In order to be used in a such wide variety of sectors and countries, Pizzato Elettrica position switches are made to be assembled in a lot of configurations thanks to the various body shapes, dozens of contact blocks, hundreds of actuators and materials, forces, assembling versions.

Pizzato Elettrica can offer one of the widest product range of position switches in the world. Moreover, the use of high quality materials, high reliability technologies (e.g. twin bridge contact blocks) as well as the IP67 protection degree make this range of position switches one of the most technologically evolved.

### SAFETY DEVICES

The company Pizzato Elettrica has been one of the first Italian companies developing dedicated items for this sector, creating and patenting dozens of innovative products, thus becoming one of the main European manufacturers of safety devices.

The vast range of products aimed specifically at the safety of machinery, fully designed and assembled at the Marostica (VI) company premises, includes not only more traditional safety switches with separate actuator (with or without locking mechanism) and hinge switches but also state-of-the-art anti-tampering devices with RFID technology, such as the ST series sensors, and NG and NS series locking devices.

The product range is complemented by safety handles for guards, with the innovative P-KUBE Krome model whose grip can be illuminated with multicolour signalling LEDs, as well as by the CS series safety modules, available in single function versions, or user-programmable with the use of the Gemnis Studio software; fully implemented by Pizzato Elettrica and distributed with a free licence.

### MAN-MACHINE INTERFACE

Pizzato Elettrica's control and signalling devices of the EROUND line are designed for the use in the human-machine interface sector. Thanks to the elegant design, the care for details and the elegance of the product combined with its maximum safety and reliability, this series is one of the most complete and cutting-edge on the market.

In order to satisfy its customers' needs and requests, Pizzato Elettrica offers a lot of accessories purposely designed not only to complete its wide range of products, but also to help device installation on machineries.



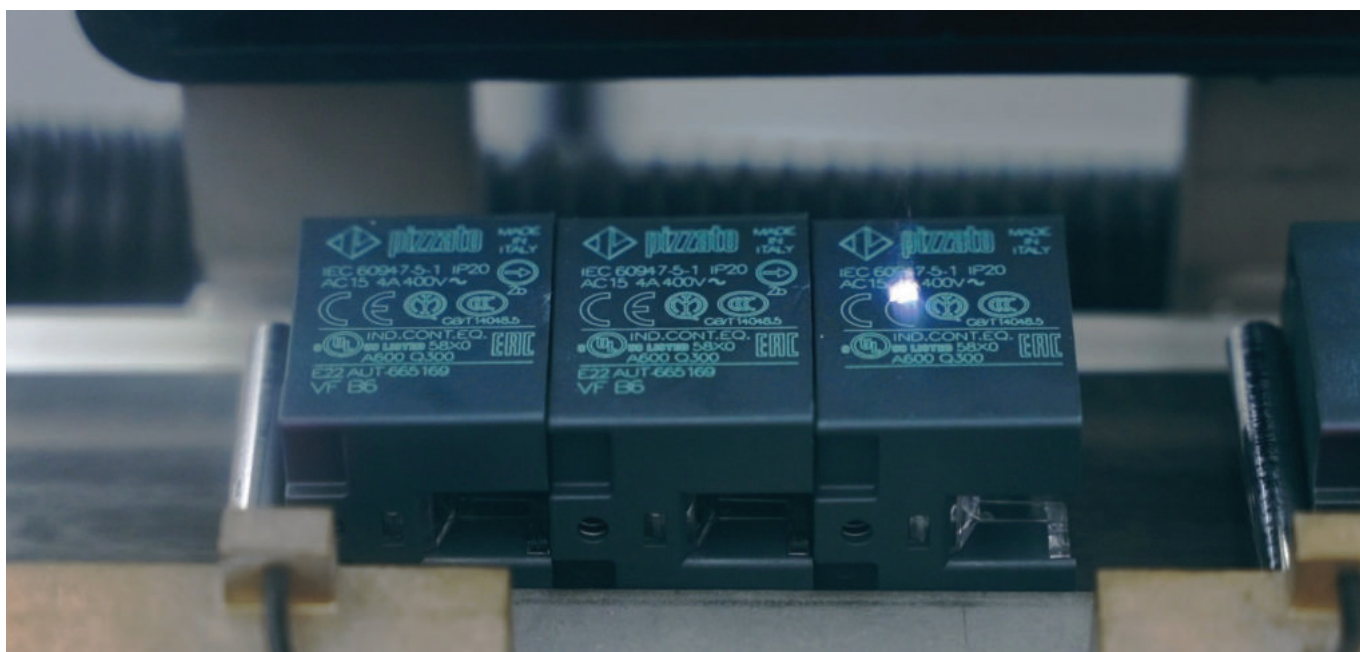

## MILLIONS OF CERTIFIED PRODUCT CODES

A simple brand isn't enough: the company is aiming for the Pizzato Elettrica brand to be widely recognised as a synonym for absolute quality and certainty.

A result that has been reached and consolidated over the years, updating and expanding the series of certifications obtained from the most important Italian and international control organisations. Product quality is assessed by seven accredited external bodies: IMQ, UL, CCC, TÜV SÜD, EAC, BSI, BV. These bodies lay out high technical and qualitative standards for the company to achieve and maintain, verified yearly with several inspections: these are performed, without prior notice, by qualified inspectors, who extract samples of products and materials destined for sale from plants, or from the market directly, to subject them to apposite tests.

- **CE MARK.** All Pizzato Elettrica products bear the CE marking in conformity with the European Directives in force.
- **UKCA MARK.** All Pizzato Elettrica products bear the UKCA marking in conformity with the United Kingdom directives in force.
- **ISO 9001 CERTIFICATION.** The company's production system is compliant with the international ISO 9001 standard, in its most recent 2015 revision. The certification covers all of the company's plants and their production and managerial activities: entry checks,

technical, purchasing and commercial department activities, manufacturing operations assessments, final pre-shipping product tests and checks, equipment reviews and the management of the metrological lab.

The Pizzato Elettrica quality management system ensures that all sensitive company processes – from component design to implementation, from materials provisioning to verification of non-compliant products – are carried out according to the procedures laid down, with the aim of providing our customers with continuously improved and reliable products.

- **CERTIFICATION OF COMPANY QUALITY SYSTEMS.** Pizzato Elettrica has obtained the certificate of compliance with the UNI EN ISO 9000 regulations in force in Italy and abroad. It is issued by a recognised independent body that guarantees the quality and reliability of the service offered to clients worldwide.
- **CSQ, CISQ AND IQNET.** The CSQ system is part of the CISQ (Italian Certification of Quality Systems) federation, which consists of the primary certification bodies operating in Italy in the various product sectors. CISQ is the Italian representative body within IQNet, the biggest international Quality Systems and Company Management certification network, which is adhered to by 25 certification organs in as many countries.







## GLOBAL SUBSIDIARIES

**Pizzato Deutschland GmbH**  
Munich  
Founding year: 2013  
info@pizzato.com

**Pizzato France Sarl**  
Villeurbanne - Lyon  
Founding year: 2016  
info@pizzato.com

**Pizzato Iberica SL**  
Barcelona  
Founding year: 2017  
info@pizzato.com

**Pizzato USA**  
East Syracuse, NY  
Founding year: 2018  
info@pizzatousa.com

**Pizzato Elettrica India Ltd.**  
Pune  
Founding year: 2021  
info@pizzato.com

**Pizzato Korea Ltd.**  
Seoul  
Founding year: 2021  
info@pizzato.com

The purpose of these subsidiaries is to coordinate and support the activities of representative agencies, or distributors, present in the various countries, managing marketing and sales activities, with further objectives of increasing brand visibility and penetration capacity of Pizzato Elettrica products in markets considered strategic.

Products from Pizzato Elettrica are currently used in over 80 countries: The commercial support network, which is made up of local professional and experienced representatives, combined with the productive capacity of the headquarters in Italy, are the basis for the formation of a group that, together with its partners, has all the necessary requirements to become one of the most important companies in the field of automation and industrial safety.

## TECHNICAL AND SALES ASSISTANCE



### TECHNICAL DEPARTMENT

The Pizzato Elettrica technical department provides direct technical and qualified assistance in Italian and English, helping in this way the customers to choose the suitable product for their own application explaining the characteristics and the correct installation.

Office hours: Monday to Friday  
08:00 am - 12:30 pm / 02:00 pm - 05:30 pm CET

Telephone: +39.0424.470.930

E-mail: tech@pizzato.com

Spoken languages:  

### SALES DEPARTMENT

Among the strengths in the company relationship with the commercial network, the direct assistance guaranteed in five languages: Italian, English, French, German and Spanish. A service that confirms Pizzato Elettrica quality and attention to the needs of customers from around the world.

Office hours: Monday to Friday  
08:00 am - 12:30 pm / 02:00 pm - 05:30 pm CET

Telephone: +39.0424.470.930

E-mail: info@pizzato.com

Spoken languages:     





## TRADE FAIRS AND EVENTS

### TRADE FAIRS

Pizzato Elettrica regularly participate to many trade fairs in Italy and abroad, presenting in this way to the market the products, the latest news, etc.

### EVENTS

Besides offering qualified technical assistance, Pizzato Elettrica presents itself as a dynamic partner who is attentive to the needs of its customers. For this reason, the company organises several meetings and training courses with particular attention to the regulatory aspect of machinery safety.

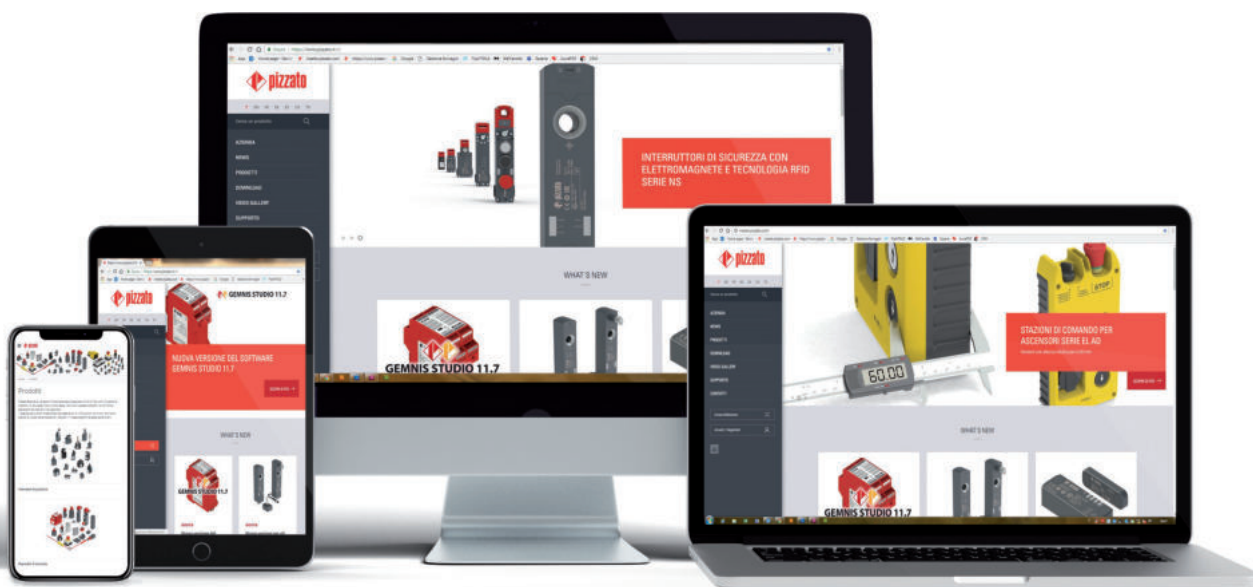

## WEBSITE WWW.PIZZATO.IT

### PRODUCT NEWS

Visit the website at [www.pizzato.com](http://www.pizzato.com) to stay updated on all the news regarding product launches, to view the entire range of products created by Pizzato Elettrica, and to consult all the documentation provided.

### SEARCH USING FILTERS

You can find the product you want by entering the relative item code, or use the filters provided to create the item most adapted to your particular requirements, by choosing the features it needs to offer.

### BROWSABLE, DOWNLOADABLE CATALOGUE

Users can download the complete catalogue or alternatively browse it directly online, an extremely handy solution for those wishing to consult the range of products simply and rapidly.

### HIGH RESOLUTION IMAGES

The information provided for each product is complete with high resolution images to offer visitors to the website a clear, accurate view of the items in close detail, also offering them the possibility to zoom in and out on the image.

### USAGE INSTRUCTIONS

You can download product usage or installation instructions, in PDF format, to your computer.

### 2D AND 3D FILES

2D and 3D drawings are available for every item; in formats that are compatible with the widest variety of drawing programs.

### CERTIFICATES AND EC DECLARATIONS OF CONFORMITY

The latest product type approval certificates, and EC declarations of conformity in accordance with applicable European product directives, are published on the website.

### LARGE VIDEO SECTION

The large video section of the website is capable of showcasing the main characteristics, functions and use of the various products.

### MULTILINGUAL TRANSLATIONS

The website's multilingual versions allow the clients of the global market to find all the information they need in one place.

### WEBINARS

The webinars from Pizzato Elettrica go into detail in the area of machine safety with focus on the further development of standards. The speakers are experts with targeted specialisation and detailed knowledge of standards and directives in the industry.

### CROSS-REFERENCE

It is possible to find a Pizzato Elettrica product as an alternative to others on the market in terms of functionality.

## Restyling of position switches for standard applications

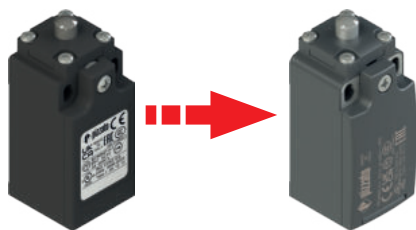

- Modern design with rounded shapes
- Housing in anthracite-grey technopolymer
- Laser engraving, which is indelible and weather resistant
- Hinged cover, equipped with built-in gasket and fixed with single captive screw for easier wiring (series FR, FK, FM and FX).
- Metal plates (available in stainless steel on request) on mounting holes of the housing, in order to guarantee even more secure fixing (series FR, FK and FX).
- Protection degree IP67, and up to IP69K for switches without exposed rubber parts.
- New levers with the option to adjust the height of the actuator and its radial position.
- Standard M20 thread also for FK series.



## New actuator 17

- Compatible with FD, FP, FL, FC series.
- Short actuator with roller plunger: the reduced length of this new actuator allows the switch to be used in applications with little available space.
- AISI 316 stainless steel roller.



## High reliability contacts with "V" design for series NA, NB

- Better reliability of the contact.
- Self-cleaning against dust and dirt.
- Contact points doubled compared to flat contacts.
- Suitable for reduced currents.
- Suitable for applications in the rail sector.

► 114



## Connectors M8, M12 with new fixing ring, M23

- Large selection of connectors for cables and switch panels: optimal solution for use in combination with Pizzato switches.
- M12 connectors with new fixing ring with grooved circular and hexagonal attachment for tightening with torque-controlled tools. Available in male and female versions.
- Gold-plated contacts for increased reliability.
- Anti-vibration self-locking ring nuts.
- Highly flexible cables, suitable for use in drag chains, with oil-resistant PVC or PUR sheath acc. to IEC 60332-1-2.

► 209



AISI 316L

## New AISI 316L stainless steel rollers

- AISI 316L stainless steel rollers are ideal for use in especially acidic or saline environments.
- The rollers are available with diameters of 20, 14, 12 mm.
- Available for position switches for normal and harsh applications as an option for prewired switches with codes R41, R43, R44.

► 13



## UL approval: outdoor

- Although the quality of Pizzato products has been proven for some time now, they are constantly updated to guarantee higher quality and reliability.
- With this in mind, product approvals are continuously renewed and extended by certified authorities.
- The UL approval of Pizzato switches has been updated to the outdoor category, with ratings up to type 4X, 6, 12, 13: this indicates maximum levels of protection against corrosion, oil, atmospheric influence and ingress of liquids.
- These results are achieved thanks to constant research and development and precise evaluations of every single detail, involving design, choice of materials and coatings, up to the many required conformity tests.



## UKCA declaration of conformity

- Following the withdrawal of the United Kingdom from the European Union, the UKCA mark (UK Conformity Assessment) for products that are placed on the market in Great Britain must be used instead of the European CE marking. For products that previously required a CE marking, the new UKCA mark for Great Britain (England, Scotland and Wales), in effect since 1 January 2021, is required.
- At the time of printing this catalogue, the British government specified 1 January 2025 as the date from which the UKCA mark will be mandatory for products that are placed on the market in Great Britain; the UKCA mark can also be used prior to this date.
- Pizzato Elettrica has already started to update the mark and will mark its own products with the newly required mark within the time frame specified in the last legislative changes.



## New tamper-proof protections for M12 connectors, VF PC series

- New version ensuring additional protection against tampering with the electrical connections.
- Quick assembly with two interlocking shells.
- Removal possible only by breaking the shells.
- Different versions available for connector - device and male connector - female connector connections.
- Versions available in detectable blue plastic, suitable for the food industry.

► 223



## Stock items

An overview of stock items is available at [www.pizzato.com](http://www.pizzato.com)

## Description

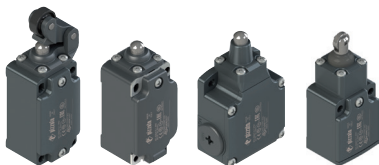

Pizzato Elettrica position switches are daily installed in every type of industrial machinery all over the world for applications in the sector of wood, metal, plastic, automotive, packaging, lifting, medicinal, naval, etc.

In order to be used in a wide variety of sectors and countries, Pizzato Elettrica position switches are designed to be assembled in a lot of configurations, thanks to a wide range of body shapes, dozens of contact blocks, hundreds of actuators and materials, different actuating forces and several fixing methods.

Pizzato Elettrica can offer one of the widest product range of position switches in the world. Moreover, the use of high quality materials, high reliability technologies (e.g. twin bridge contact blocks) as well as the IP67 protection degree make this range of position switches one of the most technologically evolved.

## Protection degree IP67

**IP67** These devices are designed to be used under the toughest environmental conditions, and they pass the IP67 immersion test acc. to EN 60529. They can therefore be used in all environments where the maximum degree of protection is required for the housing.

## Extended temperature range

**-40°C** These devices are also available in a special version suitable for an ambient operating temperature range from -40°C up to +80°C.

They can therefore be used for applications in cold stores, sterilisers, and other equipment operated in very low-temperature environments. The special materials used to produce these versions retain their characteristics even under these conditions, thereby expanding the installation possibilities.

## Laser engraving



All devices are marked using a dedicated indelible laser system. These engravings are therefore suitable for extreme environments too. Thanks to this system that does not use labels, the loss of plate data is prevented and a greater resistance of the marking is achieved over time.

## Reversible levers

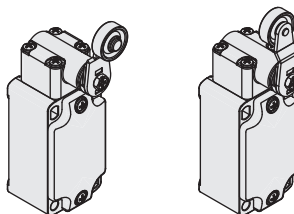

For switches with swivelling lever, the lever can be fastened on straight or reverse side maintaining the positive coupling. In this way two different working planes of the lever are possible.

## Adjustable levers

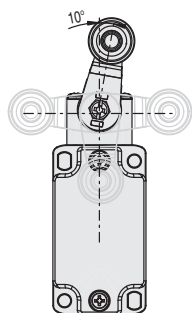

For switches with swivelling lever, the lever can be adjusted in 10° steps over the entire 360° range. The positive movement transmission is always guaranteed thanks to the particular geometrical coupling between the lever and the revolving shaft as prescribed for safety applications by the German standard BG-GS-ET-15.

## Adjustable safety lever

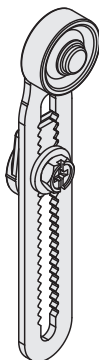

The adjustable lever code 56 (and variants) is provided with a notching that prevents the sliding also in case the fastening screw becomes loose. Thanks to the special geometrical coupling it is suitable for safety applications.

## Head with variable orientation

For all switches the head can be rotated in 90° steps.

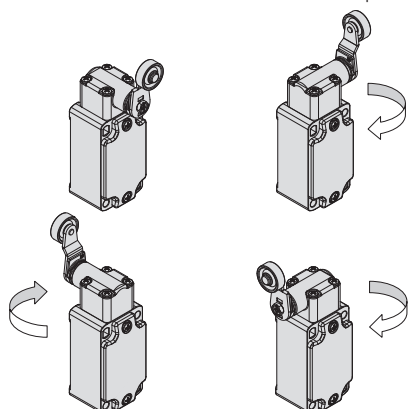

## Increased or reduced actuating force

For actuators with swivelling lever, versions with increased or reduced actuating force are available upon request, in order to have a switch perfectly tailored for the application. For further information contact our technical department.

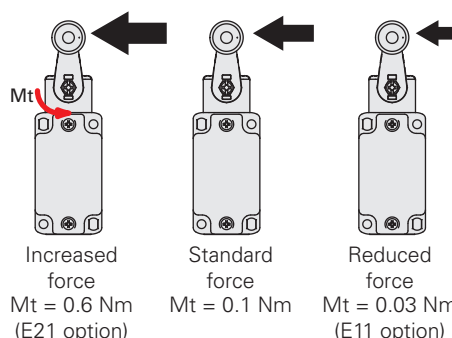

### Independent contacts

The contact block 16 is provided with two NC contacts, **both with positive opening**, that can be independently switched depending on the lever turning direction.

Lever turned to left

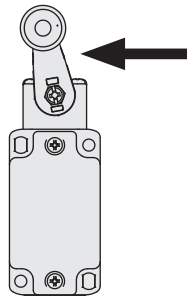
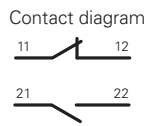

Lever not actuated

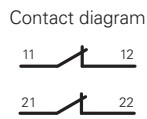

Lever turned to right

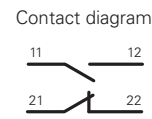

### Unidirectional heads

For switches with swivelling lever, the unidirectional operation can be set by removing the four head screws and rotating the internal plunger (except contact block 16).

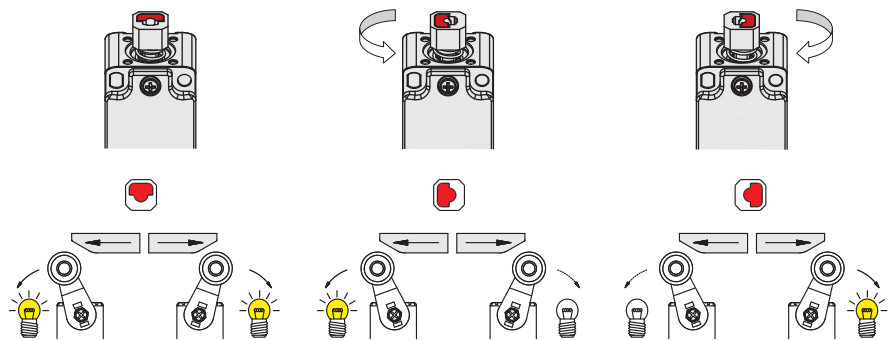
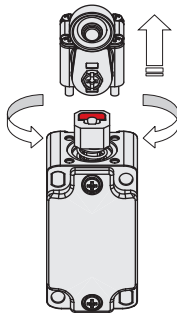

### Actuator for wall or ceiling applications



For the heavy-duty FD, FP, FL, FC series, actuator 09 is available which, thanks to a sturdy actuation lever, allows the switch to be activated with a rope or stay bolt. This type of actuation is particularly useful, where the device requires wall or ceiling installation for particular applications; such as control of sectional or overhead gates.

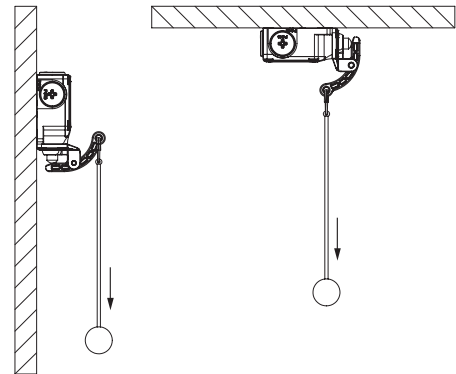

### Contact blocks

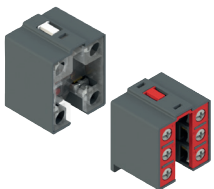

Contact blocks with captive screws, finger protection, twin bridge contacts and double interruption for higher contact reliability. They are available in multiple variants with shifted activation travels, simultaneous or overlapping. They are suitable for many different applications.

### Stainless steel fixing plates

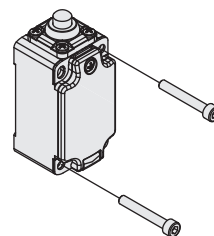

The technopolymer switches of the FP series are provided with two robust stainless steel fixing plates. In this way no washer is needed under the head and still the fixing of the switch is more stable over time.

### Gold-plated contacts

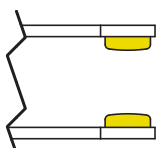

The contact blocks of these devices can be supplied gold-plated upon request. Ideal for applications with low voltages or currents; it ensures increased contact reliability. Available in two thicknesses (1 or 2.5 microns), it adapts perfectly to the various fields of application, ensuring a long endurance over time.

### Stainless steel external metallic parts

**STAINLESS STEEL**

Upon request, some of these devices can be supplied with stainless steel external metallic parts instead of the usual zinc-plated steel. This solution is particularly suited for environments where aggressive chemical agents or saline mist are present. The steel rollers of the actuators are available in the standard version made of steel with self-lubrication or in the version made of 316L stainless steel, which is preferred if even higher corrosion resistance is necessary. See page 201.

## Selection diagram

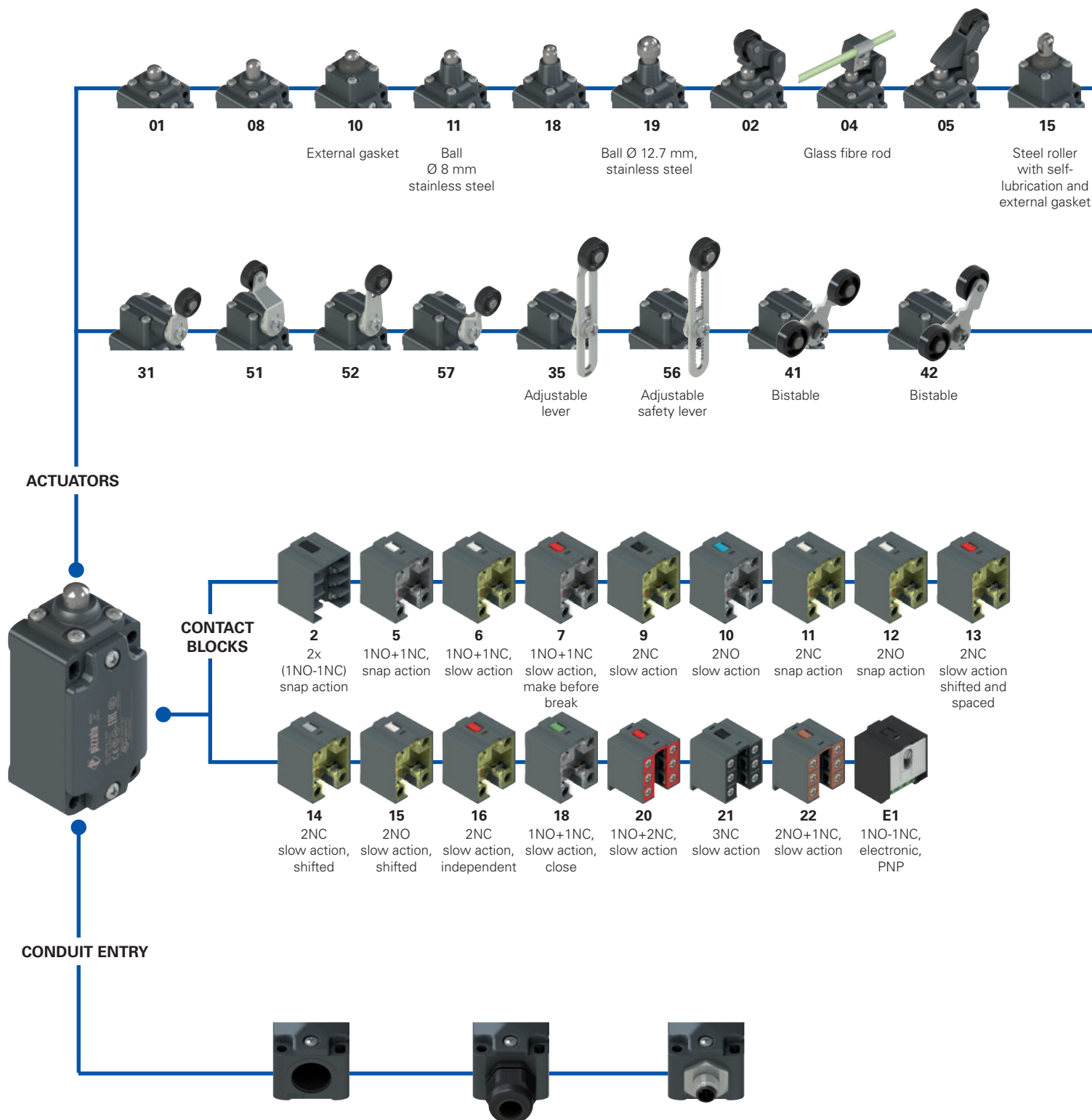

Threaded conduit entry	
<b>M2</b>	M20x1.5 (standard) PG 13.5

With cable gland	
<b>K23</b>	for cables Ø 6 ... 12 mm
<b>K27</b>	for cables Ø 3 ... 7 mm

With M12 metal connector	
<b>K40</b>	8-pole
<b>K50</b>	5-pole

- Product options
- Sold separately as accessory



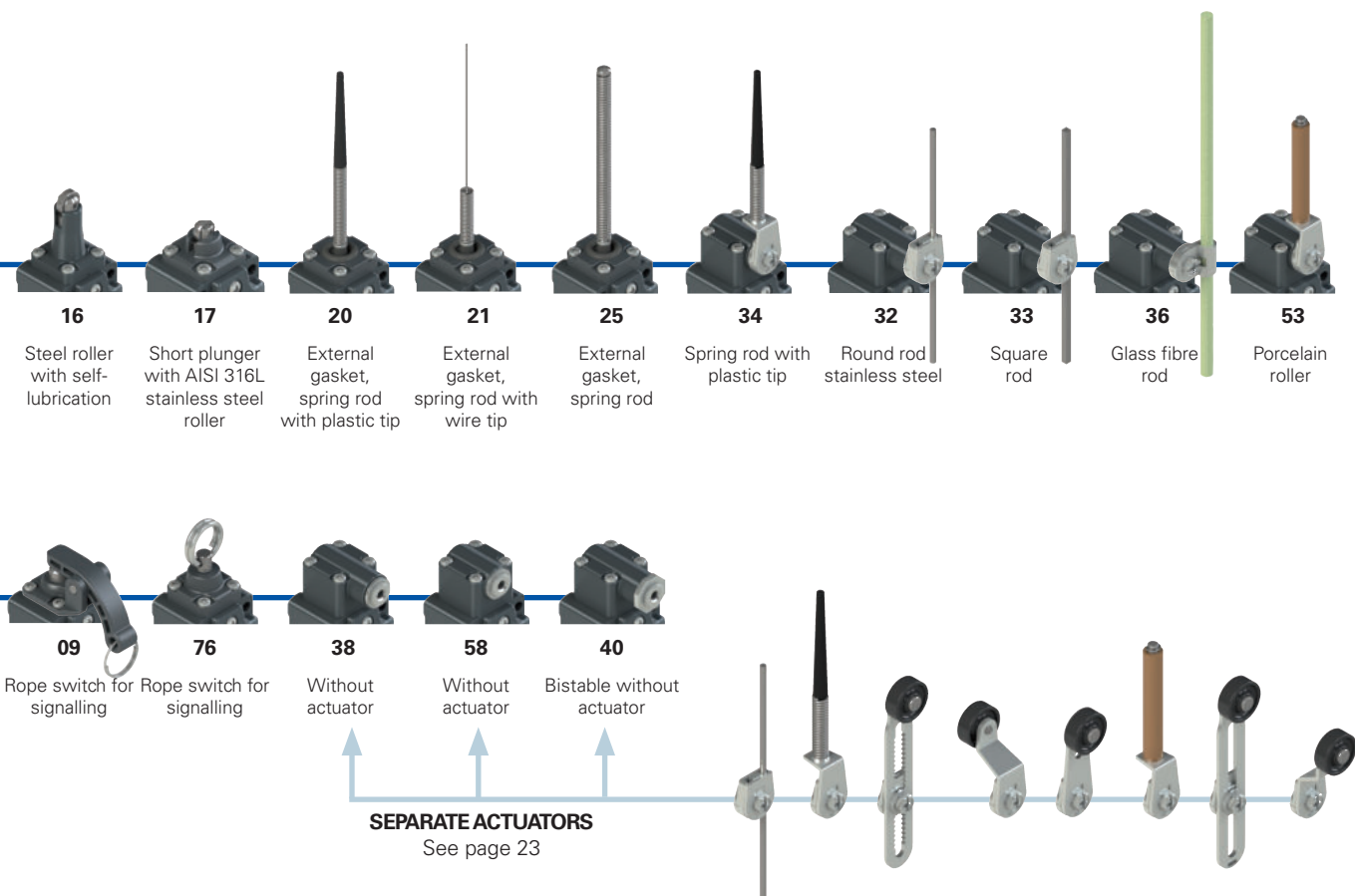

**Code structure** **Attention!** The feasibility of a code number does not mean the effective availability of a product. Please contact our sales office.

article
options
options  
**FD 502-GM2K50R24T6**

<b>Housing</b>		<b>Ambient temperature</b>	
<b>FD</b>	metal, one conduit entry		-25°C ... +80°C (standard)
<b>Contact block</b>		<b>T6</b>	-40°C ... +80°C
<b>5</b>	1NO+1NC, snap action	<b>Rollers</b>	
<b>6</b>	1NO+1NC, slow action		standard roller
<b>7</b>	1NO+1NC, slow action, make before break	<b>R24</b>	Steel, with self-lubrication, Ø 20 mm (for actuators 02, 05, 31, 35, 51, 52, 56, 57)
...	...	<b>R41</b>	316L stainless steel, Ø 20 mm (for actuators 02, 05, 31, 35, 51, 52, 56, 57)
<b>Actuators</b>		<b>R25</b>	technopolymer, Ø 35 mm (for actuators 31, 35, 51, 52, 56, 57)
<b>01</b>	short plunger	<b>R5</b>	rubber, Ø 40 mm (for actuators 31, 35, 51, 52, 56, 57)
<b>02</b>	roller lever	<b>R26</b>	rubber, Ø 50 mm (for actuators 31, 35, 51, 52, 56, 57)
<b>05</b>	angled lever with roller	<b>R27</b>	rubber, protruding, Ø 50 mm (for actuators 35 and 56)
...	...	<b>Pre-installed cable glands or connectors</b>	
<b>Contact type</b>			no cable gland or connector (standard)
	silver contacts (standard)	<b>K23</b>	cable gland for cables Ø 6 ... 12 mm
<b>G</b>	silver contacts, 1 µm gold coating	<b>K27</b>	cable gland for cables Ø 3 ... 7 mm
<b>G1</b>	silver contacts, 2.5 µm gold coating (not for contact block 2, 20, 21, 22)	<b>K40</b>	M12 metal connector, 8-pole
<b>Threaded conduit entry</b>		<b>K50</b>	M12 metal connector, 5-pole
<b>M2</b>	M20x1.5 (standard)	For the complete list of possible combinations please contact our technical department.	
	PG 13.5		



### Main features

- Metal housing, one conduit entry
- Protection degree IP67
- 17 contact blocks available
- 29 actuators available
- Versions with M12 connector
- Versions with gold-plated silver contacts

### Technical data

#### Housing

Metal housing, powder-coated  
 One threaded conduit entry: M20x1.5 (standard)  
 Protection degree acc. to EN 60529: IP67 with cable gland of equal or higher protection degree

#### General data

Ambient temperature: -25°C ... +80°C (standard)  
 -40°C ... +80°C (T6 option)  
 Max. actuation frequency: 3600 operating cycles/hour  
 Mechanical endurance: 20 million operating cycles  
 Mounting position: any  
 Safety parameter B<sub>10D</sub>: 40,000,000 for NC contacts  
 Mechanical interlock, not coded: type 1 acc. to EN ISO 14119  
 Tightening torques for installation: see page 229  
 Wire cross-sections and wire stripping lengths: see page 249

#### In compliance with standards:

IEC 60947-5-1, EN 60947-5-1, EN 60947-1, EN 50041, IEC 60204-1, EN 60204-1, EN ISO 14119, EN ISO 12100, IEC 60529, EN 60529, EN IEC 63000, UL 508, CSA C22.2 No. 14.

#### Approvals:

IEC 60947-5-1, UL 508, CSA C22.2 No. 14, GB/T14048.5.

#### Compliance with the requirements of:

Low Voltage Directive 2014/35/EU, EMC Directive 2014/30/EU, RoHS Directive 2011/65/EU.

#### Positive contact opening in conformity with standards:

IEC 60947-5-1, EN 60947-5-1.

### Quality marks:



IMQ approval: EG605  
 UL approval: E131787  
 CCC approval: 2021000305000099  
 EAC approval: RU C-IT.YT03.B.00035/19

### Installation for safety applications:

Use only switches marked with the  $\ominus$  symbol beside the product code. Always connect the safety circuit to the **NC contacts** (normally closed contacts: 11-12, 21-22 or 31-32) as required by **EN ISO 14119, paragraph 5.4** for specific interlock applications and **EN ISO 13849-2 tables D3** (well-tried components) and **D.8** (fault exclusions) for safety applications in general. Actuate the switch **at least up to the positive opening travel** shown in the travel diagrams on page 230. Actuate the switch **at least with the positive opening force**, reported in brackets below each article, next to the actuating force value.

**⚠ If not expressly indicated in this chapter, for correct installation and utilization of all articles see the instructions given on pages 227 to 242.**

	Electrical data	Utilization category
without connector	Thermal current (I <sub>th</sub> ):	10 A
	Rated insulation voltage (U <sub>i</sub> ):	500 Vac 600 Vdc 400 Vac 500 Vdc (contact blocks 2, 11, 12, 20, 21, 22)
	Rated impulse withstand voltage (U <sub>imp</sub> ):	6 kV 4 kV (contact blocks 20, 21, 22)
	Conditional short circuit current: Protection against short circuits: Pollution degree:	1000 A acc. to EN 60947-5-1 type aM fuse 10 A 500 V 3
with M12 connector, 5-pole	Thermal current (I <sub>th</sub> ):	4 A
	Rated insulation voltage (U <sub>i</sub> ):	250 Vac 300 Vdc
	Protection against short circuits: Pollution degree:	type gG fuse 4 A 500 V 3
		Alternating current: AC15 (50±60 Hz) U <sub>e</sub> (V) 250 400 500 I <sub>e</sub> (A) 6 4 1 Direct current: DC13 U <sub>e</sub> (V) 24 125 250 I <sub>e</sub> (A) 3 0.55 0.3
with M12 connector, 8-pole	Thermal current (I <sub>th</sub> ):	2 A
	Rated insulation voltage (U <sub>i</sub> ):	30 Vac 36 Vdc
	Protection against short circuits: Pollution degree:	type gG fuse 2 A 500 V 3
		Alternating current: AC15 (50±60 Hz) U <sub>e</sub> (V) 24 I <sub>e</sub> (A) 2 Direct current: DC13 U <sub>e</sub> (V) 24 I <sub>e</sub> (A) 2



### Features approved by IMQ

Rated insulation voltage (Ui): 500 Vac  
400 Vac (for contact blocks 2, 11, 12, 20, 21, 22, 28, 29, 30, 33, 34, 37)

Conventional free air thermal current (Ith): 10 A

Protection against short circuits: type aM fuse 10 A 500 V

Rated impulse withstand voltage (U<sub>imp</sub>): 6 kV  
4 kV (for contact blocks 20, 21, 22, 28, 29, 30, 33, 34)

Protection degree of the housing: IP67

MV terminals (screw terminals): 3

Pollution degree: AC15

Utilization category: 3 A

Operating voltage (Ue): 400 Vac (50 Hz)

Operating current (Ie): 3 A

Forms of the contact element: Za, Za+Za, X+X, Zb, Y+Y, Y+Y+X, Y+Y+Y, Y+X+X, Y, X.

Positive opening of contacts on contact blocks 5, 6, 7, 8, 9, 11, 13, 14, 16, 17, 18, 19, 20, 21, 22, 28, 29, 30, 33, 34, 37, 38, 39, 66.

In compliance with standards: EN 60947-1, EN 60947-5-1, fundamental requirements of the Low Voltage Directive 2014/35/EU.

Please contact our technical department for the list of approved products.

### Features approved by UL

Electrical Ratings: Q300 pilot duty (69 VA, 125-250 V dc)  
A600 pilot duty (720 VA, 120-600 V ac)

Environmental Ratings: Types 1, 4X, 12, 13

For all contact blocks except 2 and 3 use 60 or 75°C copper (Cu) conductors, rigid or flexible, wire size 12, 14 AWG. Tightening torque for terminal screws of 7.1 lb in (0.8 Nm).

For contact blocks 2 and 3 use 60 or 75°C copper (Cu) conductors, rigid or flexible, wire size 14 AWG. Tightening torque for terminal screws of 12 lb in (1.4 Nm).

Please contact our technical department for the list of approved products.

### Wiring diagram for M12 connectors

Contact block 2 2x(1NO-1NC)	Contact block 5 1NO+1NC	Contact block 6 1NO+1NC	Contact block 7 1NO+1NC	Contact block 9 2NC	Contact block 10 2NO	Contact block 11 2NC	Contact block 12 2NO	Contact block 13 2NC
<b>Contacts</b> Pin no. NO 3-4 NC 5-6 NC 7-8 NO 1-2	<b>Contacts</b> Pin no. NC 1-2 NO 3-4 ground 5	<b>Contacts</b> Pin no. NC 1-2 NO 3-4 ground 5	<b>Contacts</b> Pin no. NC 1-2 NO 3-4 ground 5	<b>Contacts</b> Pin no. NC 1-2 NC 3-4 ground 5	<b>Contacts</b> Pin no. NO 1-2 NO 3-4 ground 5	<b>Contacts</b> Pin no. NC 1-2 NC 3-4 ground 5	<b>Contacts</b> Pin no. NO 1-2 NO 3-4 ground 5	<b>Contacts</b> Pin no. NC (1°) 1-2 NC (2°) 3-4 ground 5

Contact block 14 2NC	Contact block 15 2NO	Contact block 16 2NC	Contact block 18 1NO+1NC	Contact block 20 1NO+2NC	Contact block 21 3NC	Contact block 22 2NO+1NC	Contact block 33 1NO+1NC	Contact block 34 2NC
<b>Contacts</b> Pin no. NC (1°) 1-2 NC (2°) 3-4 ground 5	<b>Contacts</b> Pin no. NO (1°) 1-2 NO (2°) 3-4 ground 5	<b>Contacts</b> Pin no. NC, lever to the right 1-2 NC, lever to the left 3-4 ground 5	<b>Contacts</b> Pin no. NC 1-2 NO 3-4 ground 5	<b>Contacts</b> Pin no. NC 3-4 NC 5-6 NO 7-8 ground 1	<b>Contacts</b> Pin no. NC 3-4 NC 5-6 NC 7-8 ground 1	<b>Contacts</b> Pin no. NC 3-4 NO 5-6 NO 7-8 ground 1	<b>Contacts</b> Pin no. NC 1-2 NO 3-4 ground 5	<b>Contacts</b> Pin no. NC 1-2 NC 3-4 ground 5

Contact block E1  
PNP

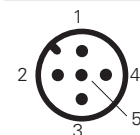

M12 connector, 5-pole

Contacts	Pin no.
+	1
-	3
NC	2
NO	4
ground	5

Contact type		With steel roller with self-lubrication or 316L stainless steel on request		With steel roller with self-lubrication or 316L stainless steel on request		With steel roller with self-lubrication or 316L stainless steel on request	
<b>R</b>	= snap action						
<b>L</b>	= slow action						
<b>LO</b>	= slow action, make before break						
<b>LS</b>	= slow action, shifted						
<b>LV</b>	= slow action, shifted and spaced						
<b>LI</b>	= slow action, independent						
<b>LA</b>	= slow action, close						
<b>E</b>	= electronic, PNP						
Contact block		With steel roller with self-lubrication or 316L stainless steel on request		With steel roller with self-lubrication or 316L stainless steel on request		With steel roller with self-lubrication or 316L stainless steel on request	
2	<b>R</b> FD 201-M2 2x(1NO-1NC)	FD 202-M2 2x(1NO-1NC)	FD 204-M2 2x(1NO-1NC)	FD 205-M2 2x(1NO-1NC)			
5	<b>R</b> FD 501-M2 1NO+1NC	FD 502-M2 1NO+1NC	FD 504-M2 1NO+1NC	FD 505-M2 1NO+1NC			
6	<b>L</b> FD 601-M2 1NO+1NC	FD 602-M2 1NO+1NC	FD 604-M2 1NO+1NC	FD 605-M2 1NO+1NC			
7	<b>LO</b> FD 701-M2 1NO+1NC	FD 702-M2 1NO+1NC	FD 704-M2 1NO+1NC	FD 705-M2 1NO+1NC			
9	<b>L</b> FD 901-M2 2NC	FD 902-M2 2NC	FD 904-M2 2NC	FD 905-M2 2NC			
10	<b>L</b> FD 1001-M2 2NO	FD 1002-M2 2NO	FD 1004-M2 2NO	FD 1005-M2 2NO			
11	<b>R</b> FD 1101-M2 2NC	FD 1102-M2 2NC	FD 1104-M2 2NC	FD 1105-M2 2NC			
12	<b>R</b> FD 1201-M2 2NO	FD 1202-M2 2NO	FD 1204-M2 2NO	FD 1205-M2 2NO			
13	<b>LV</b> FD 1301-M2 2NC	FD 1302-M2 2NC	FD 1304-M2 2NC	FD 1305-M2 2NC			
14	<b>LS</b> FD 1401-M2 2NC	FD 1402-M2 2NC	FD 1404-M2 2NC	FD 1405-M2 2NC			
15	<b>LS</b> FD 1501-M2 2NO	FD 1502-M2 2NO	FD 1504-M2 2NO	FD 1505-M2 2NO			
18	<b>LA</b> FD 1801-M2 1NO+1NC	FD 1802-M2 1NO+1NC	FD 1804-M2 1NO+1NC	FD 1805-M2 1NO+1NC			
20	<b>L</b> FD 2001-M2 1NO+2NC	FD 2002-M2 1NO+2NC	FD 2004-M2 1NO+2NC	FD 2005-M2 1NO+2NC			
21	<b>L</b> FD 2101-M2 3NC	FD 2102-M2 3NC	FD 2104-M2 3NC	FD 2105-M2 3NC			
22	<b>L</b> FD 2201-M2 2NO+1NC	FD 2202-M2 2NO+1NC	FD 2204-M2 2NO+1NC	FD 2205-M2 2NO+1NC			
E1	<b>E</b> FD E101-M2 1NO-1NC	FD E102-M2 1NO-1NC	FD E104-M2 1NO-1NC	FD E105-M2 1NO-1NC			
Max. speed	page 229 - type 4	page 229 - type 3	0.5 m/s	page 229 - type 3			
Actuating force	8 N (25 N ⊕)	6 N (25 N ⊕)	0.17 Nm	6 N (25 N ⊕)			
Travel diagrams	page 230 - group 1	page 230 - group 2	page 230 - group 1	page 230 - group 2			

Contact type		Rope switch for signalling		External gasket		External gasket	
<b>R</b>	= snap action						
<b>L</b>	= slow action						
<b>LO</b>	= slow action, make before break						
<b>LS</b>	= slow action, shifted						
<b>LV</b>	= slow action, shifted and spaced						
<b>LI</b>	= slow action, independent						
<b>LA</b>	= slow action, close						
<b>E</b>	= electronic, PNP						
Contact block		Rope switch for signalling		External gasket		External gasket	
2	<b>R</b> FD 208-M2 2x(1NO-1NC)	FD 209-M2 2x(1NO-1NC)	FD 210-M2 2x(1NO-1NC)	FD 211-M2 2x(1NO-1NC)			
5	<b>R</b> FD 508-M2 1NO+1NC	FD 509-M2 1NO+1NC	FD 510-M2 1NO+1NC	FD 511-M2 1NO+1NC			
6	<b>L</b> FD 608-M2 1NO+1NC	FD 609-M2 1NO+1NC	FD 610-M2 1NO+1NC	FD 611-M2 1NO+1NC			
7	<b>LO</b> FD 708-M2 1NO+1NC	FD 709-M2 1NO+1NC	FD 710-M2 1NO+1NC	FD 711-M2 1NO+1NC			
9	<b>L</b> FD 908-M2 2NC	FD 909-M2 2NC	FD 910-M2 2NC	FD 911-M2 2NC			
10	<b>L</b> FD 1008-M2 2NO	FD 1009-M2 2NO	FD 1010-M2 2NO	FD 1011-M2 2NO			
11	<b>R</b> FD 1108-M2 2NC	FD 1109-M2 2NC	FD 1110-M2 2NC	FD 1111-M2 2NC			
12	<b>R</b> FD 1208-M2 2NO	FD 1209-M2 2NO	FD 1210-M2 2NO	FD 1211-M2 2NO			
13	<b>LV</b> FD 1308-M2 2NC	FD 1309-M2 2NC	FD 1310-M2 2NC	FD 1311-M2 2NC			
14	<b>LS</b> FD 1408-M2 2NC	FD 1409-M2 2NC	FD 1410-M2 2NC	FD 1411-M2 2NC			
15	<b>LS</b> FD 1508-M2 2NO	FD 1509-M2 2NO	FD 1510-M2 2NO	FD 1511-M2 2NO			
18	<b>LA</b> FD 1808-M2 1NO+1NC	FD 1809-M2 1NO+1NC	FD 1810-M2 1NO+1NC	FD 1811-M2 1NO+1NC			
20	<b>L</b> FD 2008-M2 1NO+2NC	FD 2009-M2 1NO+2NC	FD 2010-M2 1NO+2NC	FD 2011-M2 1NO+2NC			
21	<b>L</b> FD 2108-M2 3NC	FD 2109-M2 3NC	FD 2110-M2 3NC	FD 2111-M2 3NC			
22	<b>L</b> FD 2208-M2 2NO+1NC	FD 2209-M2 2NO+1NC	FD 2210-M2 2NO+1NC	FD 2211-M2 2NO+1NC			
E1	<b>E</b> FD E108-M2 1NO-1NC	FD E109-M2 1NO-1NC	FD E110-M2 1NO-1NC	FD E111-M2 1NO-1NC			
Max. speed	page 229 - type 4	0.5 m/s	page 229 - type 4	page 229 - type 4			
Actuating force	8 N (25 N ⊕)	7 N	11 N (25 N ⊕)	8 N (25 N ⊕)			
Travel diagrams	page 230 - group 1	/	page 230 - group 1	page 230 - group 1			

All values in the drawings are in mm

Accessories See page 207

→ The 2D and 3D files are available at [www.pizzato.com](http://www.pizzato.com)



Contact type	External gasket		Ball, Ø 8 mm, stainless steel		Ball, Ø 12.7 mm, stainless steel										
<b>R</b> = snap action	<b>L</b> = slow action	<b>LO</b> = slow action, make before break	<b>LS</b> = slow action, shifted	<b>LV</b> = slow action, shifted and spaced	<b>LI</b> = slow action, independent	<b>LA</b> = slow action, close	<b>A</b> = electronic, PNP								
<b>2</b>	<b>5</b>	<b>6</b>	<b>7</b>	<b>9</b>	<b>10</b>	<b>11</b>	<b>12</b>	<b>13</b>	<b>14</b>	<b>15</b>	<b>18</b>	<b>20</b>	<b>21</b>	<b>22</b>	<b>E1</b>
<b>FD 215-M2</b>	<b>FD 515-M2</b>	<b>FD 615-M2</b>	<b>FD 715-M2</b>	<b>FD 915-M2</b>	<b>FD 1015-M2</b>	<b>FD 1115-M2</b>	<b>FD 1215-M2</b>	<b>FD 1315-M2</b>	<b>FD 1415-M2</b>	<b>FD 1515-M2</b>	<b>FD 1815-M2</b>	<b>FD 2015-M2</b>	<b>FD 2115-M2</b>	<b>FD 2215-M2</b>	<b>FD E115-M2</b>
2x(1NO-1NC)	1NO+1NC	1NO+1NC	1NO+1NC	2NC	2NO	2NC	2NO	2NC	2NC	2NO	1NO+1NC	1NO+2NC	3NC	2NO+1NC	1NO-1NC
page 229 - type 2		page 229 - type 2		page 229 - type 4		page 229 - type 4		page 229 - type 4		page 229 - type 4		page 229 - type 4		page 229 - type 4	
11 N (25 N		8 N (25 N		8 N (25 N		8 N (25 N		8 N (25 N		8 N (25 N		8 N (25 N		8 N (25 N	
page 230 - group 1		page 230 - group 1		page 230 - group 1		page 230 - group 1		page 230 - group 1		page 230 - group 1		page 230 - group 1		page 230 - group 1	

Contact type	External gasket		External gasket		External gasket		Other rollers available. See page 24												
<b>R</b> = snap action	<b>L</b> = slow action	<b>LO</b> = slow action, make before break	<b>LS</b> = slow action, shifted	<b>LV</b> = slow action, shifted and spaced	<b>LI</b> = slow action, independent	<b>LA</b> = slow action, close	<b>A</b> = electronic, PNP												
<b>2</b>	<b>5</b>	<b>6</b>	<b>7</b>	<b>9</b>	<b>10</b>	<b>11</b>	<b>12</b>	<b>13</b>	<b>14</b>	<b>15</b>	<b>16</b>	<b>18</b>	<b>20</b>	<b>21</b>	<b>22</b>	<b>E1</b>			
<b>FD 220-M2</b>	<b>FD 520-M2</b>	/	/	/	<b>FD 1020-M2</b>	/	/	/	/	/	/	<b>FD 1820-M2</b>	<b>FD 2020-M2</b>	<b>FD 2120-M2</b>	<b>FD 2220-M2</b>	<b>FD E120-M2</b>			
2x(1NO-1NC)	1NO+1NC	/	/	/	2NO	/	/	/	/	/	/	1NO+1NC	1NO+2NC	3NC	2NO+1NC	1NO-1NC			
1 m/s		1 m/s		1 m/s		page 229 - type 1		page 229 - type 1		page 229 - type 1		0.09 Nm		0.08 Nm		0.14 Nm		0.1 Nm (0.25 Nm	
page 230 - group 3		page 230 - group 3		page 230 - group 3		page 230 - group 3		page 230 - group 3		page 230 - group 3		page 230 - group 3		page 230 - group 3		page 230 - group 3		page 230 - group 4	

All values in the drawings are in mm

Accessories See page 207

➔ The 2D and 3D files are available at [www.pizzato.com](http://www.pizzato.com)

# FD series position switches

- Contact type
- R** = snap action
  - L** = slow action
  - LO** = slow action, make before break
  - LS** = slow action, shifted
  - LV** = slow action, shifted and spaced
  - LI** = slow action, independent
  - LA** = slow action, close
  - △** = electronic, PNP

Contact block

		Round rod, Ø 3 mm, stainless steel	Square rod, 3x3 mm			Other rollers available. See page 24			
2	<b>R</b>	FD 232-M2	2x(1NO-1NC)	FD 233-M2	2x(1NO-1NC)	FD 234-M2	2x(1NO-1NC)	FD 235-M2	2x(1NO-1NC)
5	<b>R</b>	FD 532-M2	1NO+1NC	FD 533-M2	1NO+1NC	FD 534-M2	1NO+1NC	FD 535-M2	⊕ <sup>(1)</sup> 1NO+1NC
6	<b>L</b>	FD 632-M2	1NO+1NC	FD 633-M2	1NO+1NC	FD 634-M2	1NO+1NC	FD 635-M2	⊕ <sup>(1)</sup> 1NO+1NC
7	<b>LO</b>	FD 732-M2	1NO+1NC	FD 733-M2	1NO+1NC	FD 734-M2	1NO+1NC	FD 735-M2	⊕ <sup>(1)</sup> 1NO+1NC
9	<b>L</b>	FD 932-M2	2NC	FD 933-M2	2NC	FD 934-M2	2NC	FD 935-M2	⊕ <sup>(1)</sup> 2NC
10	<b>L</b>	FD 1032-M2	2NO	FD 1033-M2	2NO	FD 1034-M2	2NO	FD 1035-M2	2NO
11	<b>R</b>	FD 1132-M2	2NC	FD 1133-M2	2NC	FD 1134-M2	2NC	FD 1135-M2	⊕ <sup>(1)</sup> 2NC
12	<b>R</b>	FD 1232-M2	2NO	FD 1233-M2	2NO	FD 1234-M2	2NO	FD 1235-M2	2NO
13	<b>LV</b>	FD 1332-M2	2NC	FD 1333-M2	2NC	FD 1334-M2	2NC	FD 1335-M2	⊕ <sup>(1)</sup> 2NC
14	<b>LS</b>	FD 1432-M2	2NC	FD 1433-M2	2NC	FD 1434-M2	2NC	FD 1435-M2	⊕ <sup>(1)</sup> 2NC
15	<b>LS</b>	FD 1532-M2	2NO	FD 1533-M2	2NO	FD 1534-M2	2NO	FD 1535-M2	2NO
16	<b>LI</b>	FD 1632-M2	2NC	FD 1633-M2	2NC	FD 1634-M2	2NC	FD 1635-M2	⊕ <sup>(1)</sup> 2NC
18	<b>LA</b>	FD 1832-M2	1NO+1NC	FD 1833-M2	1NO+1NC	FD 1834-M2	1NO+1NC	FD 1835-M2	⊕ <sup>(1)</sup> 1NO+1NC
20	<b>L</b>	FD 2032-M2	1NO+2NC	FD 2033-M2	1NO+2NC	FD 2034-M2	1NO+2NC	FD 2035-M2	⊕ <sup>(1)</sup> 1NO+2NC
21	<b>L</b>	FD 2132-M2	3NC	FD 2133-M2	3NC	FD 2134-M2	3NC	FD 2135-M2	⊕ <sup>(1)</sup> 3NC
22	<b>L</b>	FD 2232-M2	2NO+1NC	FD 2233-M2	2NO+1NC	FD 2234-M2	2NO+1NC	FD 2235-M2	⊕ <sup>(1)</sup> 2NO+1NC
E1	<b>△</b>	FD E132-M2	1NO-1NC	FD E133-M2	1NO-1NC	FD E134-M2	1NO-1NC	FD E135-M2	1NO-1NC
Max. speed		1.5 m/s		1.5 m/s		1 m/s		page 229 - type 1	
Actuating force		0.1 Nm		0.1 Nm		0.1 Nm		0.1 Nm (0.25 Nm ⊖)	
Travel diagrams		page 230 - group 4		page 230 - group 4		page 230 - group 4		page 230 - group 4	

- Contact type
- R** = snap action
  - L** = slow action
  - LO** = slow action, make before break
  - LS** = slow action, shifted
  - LV** = slow action, shifted and spaced
  - LI** = slow action, independent
  - LA** = slow action, close
  - △** = electronic, PNP

Contact block

		Glass fibre rod	Other rollers available. See page 24	Other rollers available. See page 24		Porcelain roller			
2	<b>R</b>	FD 236-M2	2x(1NO-1NC)	FD 251-M2	2x(1NO-1NC)	FD 252-M2	2x(1NO-1NC)	FD 253-E11M2	2x(1NO-1NC)
5	<b>R</b>	FD 536-M2	1NO+1NC	FD 551-M2	⊕ <sup>(1)</sup> 1NO+1NC	FD 552-M2	⊕ <sup>(1)</sup> 1NO+1NC	FD 553-E11M2V9	⊕ <sup>(1)</sup> 1NO+1NC
6	<b>L</b>	FD 636-M2	1NO+1NC	FD 651-M2	⊕ <sup>(1)</sup> 1NO+1NC	FD 652-M2	⊕ <sup>(1)</sup> 1NO+1NC	FD 653-E11M2V9	⊕ <sup>(1)</sup> 1NO+1NC
7	<b>LO</b>	FD 736-M2	1NO+1NC	FD 751-M2	⊕ <sup>(1)</sup> 1NO+1NC	FD 752-M2	⊕ <sup>(1)</sup> 1NO+1NC	FD 753-E11M2V9	⊕ <sup>(1)</sup> 1NO+1NC
9	<b>L</b>	FD 936-M2	2NC	FD 951-M2	⊕ <sup>(1)</sup> 2NC	FD 952-M2	⊕ <sup>(1)</sup> 2NC	FD 953-E11M2V9	⊕ <sup>(1)</sup> 2NC
10	<b>L</b>	FD 1036-M2	2NO	FD 1051-M2	2NO	FD 1052-M2	2NO	FD 1053-E11M2V9	2NO
11	<b>R</b>	FD 1136-M2	2NC	FD 1151-M2	⊕ <sup>(1)</sup> 2NC	FD 1152-M2	⊕ <sup>(1)</sup> 2NC	/	/
12	<b>R</b>	FD 1236-M2	2NO	FD 1251-M2	2NO	FD 1252-M2	2NO	FD 1253-E11M2V9	2NO
13	<b>LV</b>	FD 1336-M2	2NC	FD 1351-M2	⊕ <sup>(1)</sup> 2NC	FD 1352-M2	⊕ <sup>(1)</sup> 2NC	FD 1353-E11M2V9	⊕ <sup>(1)</sup> 2NC
14	<b>LS</b>	FD 1436-M2	2NC	FD 1451-M2	⊕ <sup>(1)</sup> 2NC	FD 1452-M2	⊕ <sup>(1)</sup> 2NC	FD 1453-E11M2V9	⊕ <sup>(1)</sup> 2NC
15	<b>LS</b>	FD 1536-M2	2NO	FD 1551-M2	2NO	FD 1552-M2	2NO	FD 1553-E11M2V9	2NO
16	<b>LI</b>	FD 1636-M2	2NC	/	/	/	/	/	/
18	<b>LA</b>	FD 1836-M2	1NO+1NC	FD 1851-M2	⊕ <sup>(1)</sup> 1NO+1NC	FD 1852-M2	⊕ <sup>(1)</sup> 1NO+1NC	FD 1853-E11M2V9	⊕ <sup>(1)</sup> 1NO+1NC
20	<b>L</b>	FD 2036-M2	1NO+2NC	FD 2051-M2	⊕ <sup>(1)</sup> 1NO+2NC	FD 2052-M2	⊕ <sup>(1)</sup> 1NO+2NC	FD 2053-E11M2V9	⊕ <sup>(1)</sup> 1NO+2NC
21	<b>L</b>	FD 2136-M2	3NC	FD 2151-M2	⊕ <sup>(1)</sup> 3NC	FD 2152-M2	⊕ <sup>(1)</sup> 3NC	FD 2153-E11M2V9	⊕ <sup>(1)</sup> 3NC
22	<b>L</b>	FD 2236-M2	2NO+1NC	FD 2251-M2	⊕ <sup>(1)</sup> 2NO+1NC	FD 2252-M2	⊕ <sup>(1)</sup> 2NO+1NC	FD 2253-E11M2V9	⊕ <sup>(1)</sup> 2NO+1NC
E1	<b>△</b>	FD E136-M2	1NO-1NC	FD E151-M2	1NO-1NC	FD E152-M2	1NO-1NC	FD E153-E11M2V9	1NO-1NC
Max. speed		1.5 m/s		page 229 - type 1		page 229 - type 1		0.5 m/s	
Actuating force		0.1 Nm		0.06 Nm (0.25 Nm ⊖)		0.06 Nm (0.25 Nm ⊖)		0.03 Nm (0.25 Nm ⊖)	
Travel diagrams		page 230 - group 4		page 230 - group 4		page 230 - group 4		page 230 - group 5	

<sup>(1)</sup> Positive opening only with actuator set to max. See page 24.

All values in the drawings are in mm

Accessories See page 207

→ The 2D and 3D files are available at [www.pizzato.com](http://www.pizzato.com)



Contact type	Other rollers available. See page 24		Other rollers available. See page 24		With steel roller with self-lubrication or 316L stainless steel on request	With steel roller with self-lubrication or 316L stainless steel on request		
<ul style="list-style-type: none"> <li><b>R</b> = snap action</li> <li><b>L</b> = slow action</li> <li><b>LO</b> = slow action, make before break</li> <li><b>LS</b> = slow action, shifted</li> <li><b>LV</b> = slow action, shifted and spaced</li> <li><b>LI</b> = slow action, independent</li> <li><b>LA</b> = slow action, close</li> <li><b>A</b> = electronic, PNP</li> </ul>								
Contact block								
2	<b>R</b>	FD 256-M2	2x(1NO-1NC)	FD 257-M2	2x(1NO-1NC)	/	/	
5	<b>R</b>	FD 556-M2	1NO+1NC	FD 557-M2	1NO+1NC	FD 541-M2	1NO+1NC	
6	<b>L</b>	FD 656-M2	1NO+1NC	FD 657-M2	1NO+1NC	 Bistable switch with lyra lever, single track  S = mechanical switching point positive opening on contacts 21-22 only	 Bistable switch with lyra lever, dual track  S = mechanical switching point positive opening on contacts 21-22 only	
7	<b>LO</b>	FD 756-M2	1NO+1NC	FD 757-M2	1NO+1NC			
9	<b>L</b>	FD 956-M2	2NC	FD 957-M2	2NC			
10	<b>L</b>	FD 1056-M2	2NO	FD 1057-M2	2NO			
11	<b>R</b>	FD 1156-M2	2NC	FD 1157-M2	2NC			
12	<b>R</b>	FD 1256-M2	2NO	FD 1257-M2	2NO			
13	<b>LV</b>	FD 1356-M2	2NC	FD 1357-M2	2NC			
14	<b>LS</b>	FD 1456-M2	2NC	FD 1457-M2	2NC			
15	<b>LS</b>	FD 1556-M2	2NO	FD 1557-M2	2NO			
16	<b>LI</b>	FD 1656-M2	2NC	FD 1657-M2	2NC			
18	<b>LA</b>	FD 1856-M2	1NO+1NC	FD 1857-M2	1NO+1NC			
20	<b>L</b>	FD 2056-M2	1NO+2NC	FD 2057-M2	1NO+2NC			
21	<b>L</b>	FD 2156-M2	3NC	FD 2157-M2	3NC			
22	<b>L</b>	FD 2256-M2	2NO+1NC	FD 2257-M2	2NO+1NC			
E1	<b>A</b>	FD E156-M2	1NO-1NC	FD E157-M2	1NO-1NC			
Max. speed	page 229 - type 1		page 229 - type 1		0.5 m/s with cam at 30°			0.5 m/s with cam at 30°
Actuating force	0.1 Nm (0.25 Nm ⊕)		0.1 Nm (0.25 Nm ⊕)		0.21 Nm (0.36 Nm ⊕)			0.21 Nm (0.36 Nm ⊕)
Travel diagrams	page 230 - group 4		page 230 - group 4		/			/

Contact type	Rope switch for signalling		
<ul style="list-style-type: none"> <li><b>R</b> = snap action</li> <li><b>L</b> = slow action</li> <li><b>LO</b> = slow action, make before break</li> <li><b>LS</b> = slow action, shifted</li> <li><b>LV</b> = slow action, shifted and spaced</li> <li><b>LI</b> = slow action, independent</li> <li><b>LA</b> = slow action, close</li> <li><b>A</b> = electronic, PNP</li> </ul>			
Contact block			
2	<b>R</b>	FD 276-M2	2x(1NO-1NC)
5	<b>R</b>	FD 576-M2	1NO+1NC
6	<b>L</b>	FD 676-M2	1NO+1NC
7	<b>LO</b>	FD 776-M2	1NO+1NC
9	<b>L</b>	FD 976-M2	2NO
10	<b>L</b>	FD 1076-M2	2NC
11	<b>R</b>	FD 1176-M2	2NO
12	<b>R</b>	FD 1276-M2	2NC
13	<b>LV</b>	FD 1376-M2	2NO
14	<b>LS</b>	FD 1476-M2	2NO
15	<b>LS</b>	FD 1576-M2	2NC
16	<b>LI</b>	/	
18	<b>LA</b>	FD 1876-M2	1NO+1NC
20	<b>L</b>	FD 2076-M2	2NO+1NC
21	<b>L</b>	FD 2176-M2	3NO
22	<b>L</b>	FD 2276-M2	1NO+2NC
E1	<b>A</b>	/	
Max. speed	0.5 m/s		
Actuating force	initial 20 N - final 40 N		
Travel diagrams	page 230 - group 6		

All values in the drawings are in mm

Accessories See page 207

→ The 2D and 3D files are available at [www.pizzato.com](http://www.pizzato.com)

# 2 FD series position switches

## Position switches with swivelling lever without actuator

- Contact type
- R** = snap action
  - L** = slow action
  - LO** = slow action, make before break
  - LS** = slow action, shifted
  - LV** = slow action, shifted and spaced
  - LI** = slow action, independent
  - LA** = slow action, close
  - △** = electronic, PNP

Contact block

	Regular head	Compact head	
2	<b>R</b> FD 238-M2	2x(1NO-1NC)	FD 258-M2 2x(1NO-1NC)
5	<b>R</b> FD 538-M2	1NO+1NC	FD 558-M2 1NO+1NC
6	<b>L</b> FD 638-M2	1NO+1NC	FD 658-M2 1NO+1NC
7	<b>LO</b> FD 738-M2	1NO+1NC	FD 758-M2 1NO+1NC
9	<b>L</b> FD 938-M2	2NC	FD 958-M2 2NC
10	<b>L</b> FD 1038-M2	2NO	FD 1058-M2 2NO
11	<b>R</b> FD 1138-M2	2NC	FD 1158-M2 2NC
12	<b>R</b> FD 1238-M2	2NO	FD 1258-M2 2NO
13	<b>LV</b> FD 1338-M2	2NC	FD 1358-M2 2NC
14	<b>LS</b> FD 1438-M2	2NC	FD 1458-M2 2NC
15	<b>LS</b> FD 1538-M2	2NO	FD 1558-M2 2NO
16	<b>LI</b> FD 1638-M2	2NC	/
18	<b>LA</b> FD 1838-M2	1NO+1NC	FD 1858-M2 1NO+1NC
20	<b>L</b> FD 2038-M2	1NO+2NC	FD 2058-M2 1NO+2NC
21	<b>L</b> FD 2138-M2	3NC	FD 2158-M2 3NC
22	<b>L</b> FD 2238-M2	2NO+1NC	FD 2258-M2 2NO+1NC
E1	<b>△</b> FD E138-M2	1NO-1NC	FD E158-M2 1NO-1NC
Actuating force	0.1 Nm (0.25 Nm $\rightarrow$ )	0.06 Nm (0.25 Nm $\rightarrow$ )	0.21 Nm (0.36 Nm $\rightarrow$ )
Travel diagrams	page 230 - group 4	page 230 - group 4	/

**IMPORTANT**  
**For safety applications:** join only switches and actuators marked with symbol  $\rightarrow$  next to the product code.  
 For more information about safety applications see details on page 225.

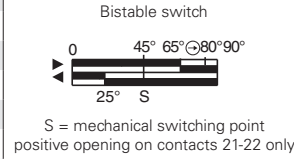

## Separate actuators

**IMPORTANT:** These separate actuators can be used only with items of the FD, FP, FL, FC series.

Technopolymer roller Ø 20 mm	Adjustable round rod Ø 3x125 mm	Adjustable square rod, 3x3x125 mm	Spring rod with plastic tip	Adjustable actuator with technopolymer roller	Adjustable glass fibre rod	
 VF L31 $\rightarrow$	 VF L32 (3)	 VF L33 (3)	 VF L34	 VF L35 $\rightarrow$ (1) (3)	 VF L36 (3)	
Lyra actuator, single track	Lyra actuator, dual track	Technopolymer roller, Ø 20 mm	Technopolymer roller, Ø 20 mm	Porcelain roller	Adjustable safety actuator with technopolymer roller	Technopolymer roller, Ø 20 mm
 VF L41 $\rightarrow$	 VF L42 $\rightarrow$	 VF L51 $\rightarrow$	 VF L52 $\rightarrow$	 VF L53 $\rightarrow$ (2)	 VF L56 $\rightarrow$ (3)	 VF L57 $\rightarrow$

All values in the drawings are in mm

Accessories See page 207

$\rightarrow$  The 2D and 3D files are available at [www.pizzato.com](http://www.pizzato.com)





## Special separate actuators

**IMPORTANT:** These separate actuators can be used only with items of the FD, FP, FL, FC series.

Steel rollers, Ø 20 mm, with self-lubrication

VF L31-R24 (1) (3)	VF L35-R24 (1) (3)	VF L51-R24 (3)	VF L52-R24 (3)	VF L56-R24 (3)	VF L57-R24 (3)

**Note:** To order with 316L stainless steel roller: replace R24 with R41 in the order numbers.

Technopolymer rollers, Ø 35 mm

VF L31-R25 (4)	VF L35-R25 (1) (3)	VF L51-R25 (4)	VF L52-R25 (3)	VF L56-R25 (3)	VF L57-R25 (3)

Rubber rollers, Ø 40 mm

VF L31-R5 (4)	VF L35-R5 (1) (3)	VF L51-R5 (4)	VF L52-R5 (3)	VF L56-R5 (3)	VF L57-R5 (4)

Rubber rollers, Ø 50 mm

VF L31-R26 (4)	VF L35-R26 (1) (3)	VF L51-R26 (4)	VF L52-R26 (4)	VF L56-R26 (3)	VF L57-R26 (4)

Protruding rubber rollers, Ø 50 mm

VF L35-R27 (1) (3)	VF L56-R27 (3)

- (1) Lever VF L35 can only be used in safety applications if adjusted to its max. length, as shown in the figure to the right. If an adjustable lever is required for safety applications, use the VF L56 adjustable safety lever.
- (2) The position switch obtained by assembling switch FD •58-M2 (e.g. FD 558-M2, FD 658-M2, ...) with actuator VF L53 will not present the same travel diagrams and actuating forces as switch FD •53-E11M2V9 (e.g. FD 553-E11M2V9, FD 653-E11M2V9, ...)
- (3) If installed with switch FD •58-M2 (e.g. FD 558-M2, FD 658-M2, ...) the actuator may hit the housing of the switch upon actuation. This possible interference depends on the fixing position of actuator and switch head.
- (4) The actuator cannot be rotated to the inside because it will hit the switch head upon actuation.

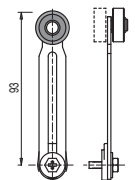

All values in the drawings are in mm

Accessories See page 207

→ The 2D and 3D files are available at [www.pizzato.com](http://www.pizzato.com)

## Selection diagram

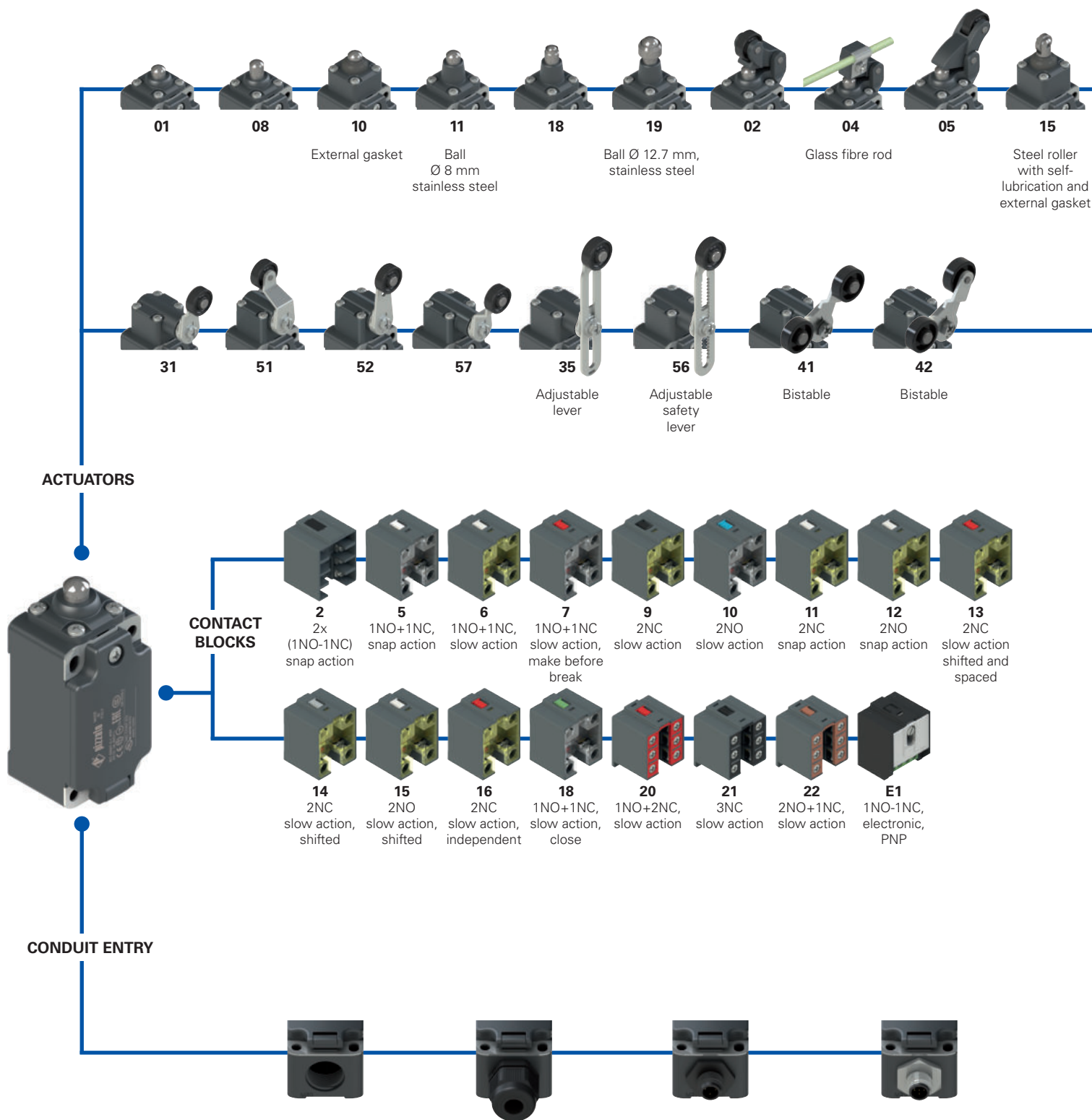

**Threaded conduit entry**

<b>M2</b>	M20x1.5 (standard) PG 13.5
-----------	-------------------------------

**With cable gland**

<b>K23</b>	for cables Ø 6 ... 12 mm
<b>K27</b>	for cables Ø 3 ... 7 mm

**With M12 plastic connector**

<b>K70</b>	4-pole, bottom
<b>K45</b>	8-pole, bottom

**With M12 metal connector**

<b>K40</b>	8-pole, bottom
<b>K60</b>	4-pole, bottom

● Product options  
→ Sold separately as accessory

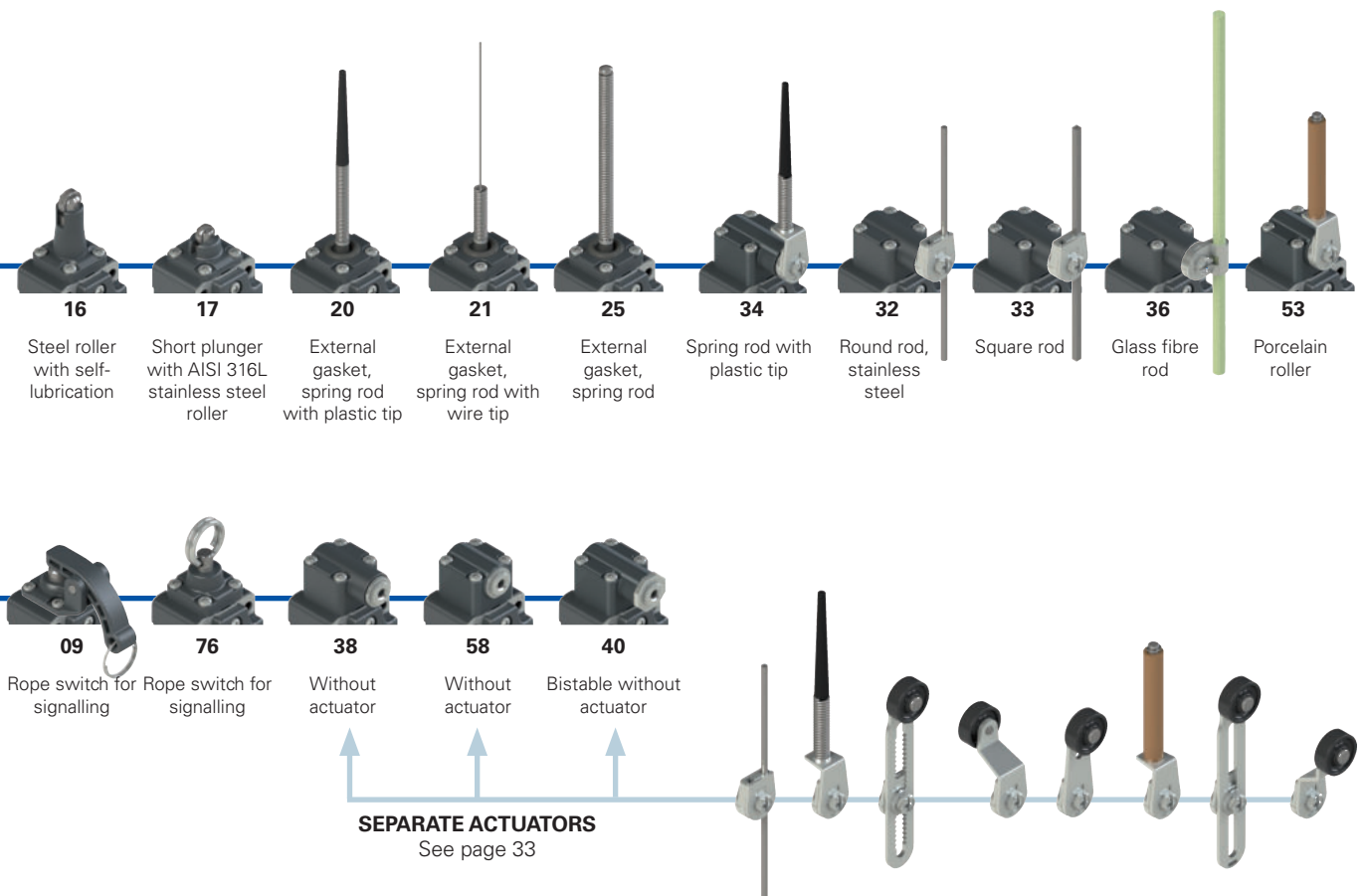
**Code structure**
**Attention!** The feasibility of a code number does not mean the effective availability of a product. Please contact our sales office.

article
options
options  
**FP 502-GM2K70R24T6**

<b>Housing</b>		<b>Ambient temperature</b>	
<b>FP</b>	technopolymer, one conduit entry		-25°C ... +80°C (standard)
<b>Contact block</b>		<b>T6</b>	-40°C ... +80°C
<b>5</b>	1NO+1NC, snap action	<b>Rollers</b>	
<b>6</b>	1NO+1NC, slow action		standard roller
<b>7</b>	1NO+1NC, slow action, make before break	<b>R24</b>	Steel, with self-lubrication, Ø 20 mm (for actuators 02, 05, 31, 35, 51, 52, 56, 57)
...	...	<b>R41</b>	316L stainless steel, Ø 20 mm (for actuators 02, 05, 31, 35, 51, 52, 56, 57)
<b>Actuators</b>		<b>R25</b>	technopolymer, Ø 35 mm (for actuators 31, 35, 51, 52, 56, 57)
<b>01</b>	short plunger	<b>R5</b>	rubber, Ø 40 mm (for actuators 31, 35, 51, 52, 56, 57)
<b>02</b>	roller lever	<b>R26</b>	rubber, Ø 50 mm (for actuators 31, 35, 51, 52, 56, 57)
<b>05</b>	angled lever with roller	<b>R27</b>	rubber, protruding, Ø 50 mm (for actuators 35 and 56)
...	...	<b>Pre-installed cable glands or connectors</b>	
<b>Contact type</b>			no cable gland or connector (standard)
	silver contacts (standard)	<b>K23</b>	cable gland for cables Ø 6 ... 12 mm
<b>G</b>	silver contacts, 1 µm gold coating	<b>K27</b>	cable gland for cables Ø 3 ... 7 mm
<b>G1</b>	silver contacts, 2.5 µm gold coating (not for contact block 2, 20, 21, 22)	<b>K45</b>	M12 plastic connector, 8-pole
<b>Threaded conduit entry</b>		<b>K70</b>	M12 plastic connector, 4-pole
<b>M2</b>	M20x1.5 (standard)	For the complete list of possible combinations please contact our technical department.	
	PG 13.5		

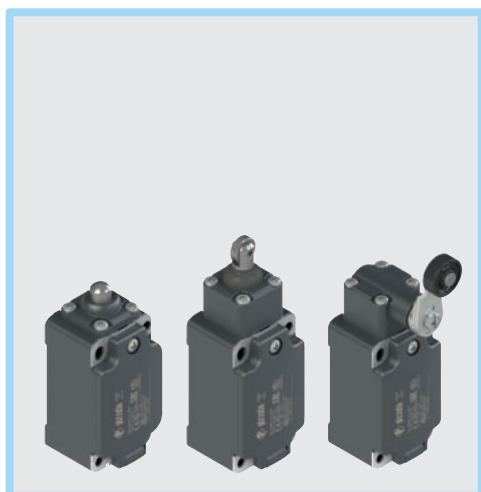

### Main features

- Technopolymer housing, one conduit entry
- Protection degree IP67
- Stainless steel fixing plates
- 17 contact blocks available
- 29 actuators available
- Versions with M12 connector
- Versions with gold-plated silver contacts

### Technical data

#### Housing

Housing made of glass fibre reinforced technopolymer, self-extinguishing, shock-proof and with double insulation:

One threaded conduit entry:

M20x1.5 (standard)

Protection degree acc. to EN 60529:

IP67 with cable gland of equal or higher protection degree

#### General data

Ambient temperature: -25°C ... +80°C (standard)

-40°C ... +80°C (T6 option)

Max. actuation frequency: 3600 operating cycles/hour

Mechanical endurance: 20 million operating cycles

Mounting position: any

Safety parameter  $B_{10D}$ : 40,000,000 for NC contacts

Mechanical interlock, not coded: type 1 acc. to EN ISO 14119

Tightening torques for installation: see page 229

Wire cross-sections and wire stripping lengths: see page 249

#### In compliance with standards:

IEC 60947-5-1, EN 60947-5-1, EN 60947-1, EN 50041, IEC 60204-1, EN 60204-1, EN ISO 14119, EN ISO 12100, IEC 60529, EN 60529, EN IEC 63000, UL 508, CSA C22.2 No. 14.

#### Approvals:

IEC 60947-5-1, UL 508, CSA C22.2 No. 14, GB/T14048.5

#### Compliance with the requirements of:

Low Voltage Directive 2014/35/EU, EMC Directive 2014/30/EU,

RoHS Directive 2011/65/EU.

#### Positive contact opening in conformity with standards:

IEC 60947-5-1, EN 60947-5-1.

### Quality marks:



IMQ approval: EG605

UL approval: E131787

CCC approval: 2021000305000099

EAC approval: RU C-IT.YT03.B.00035/19

### Installation for safety applications:

Use only switches marked with the  $\ominus$  symbol beside the product code. Always connect the safety circuit to the **NC contacts** (normally closed contacts: 11-12, 21-22 or 31-32) as required by **EN ISO 14119, paragraph 5.4** for specific interlock applications and **EN ISO 13849-2 tables D3** (well-tried components) and **D.8** (fault exclusions) for safety applications in general. Actuate the switch **at least up to the positive opening travel** shown in the travel diagrams on page 230. Actuate the switch **at least with the positive opening force**, reported in brackets below each article, next to the actuating force value.

**⚠ If not expressly indicated in this chapter, for correct installation and utilization of all articles see the instructions given on pages 227 to 242.**

	Electrical data	Utilization category
without connector	Thermal current ( $I_{th}$ ):	10 A
	Rated insulation voltage (U):	500 Vac 600 Vdc 400 Vac 500 Vdc (contact blocks 2, 11, 12, 20, 21, 22)
	Rated impulse withstand voltage ( $U_{imp}$ ):	6 kV 4 kV (contact blocks 20, 21, 22)
with M12 connector, 4-pole	Thermal current ( $I_{th}$ ):	4 A
	Rated insulation voltage (U):	250 Vac 300 Vdc
	Protection against short circuits:	type gG fuse 4 A 500 V
with M12 connector, 8-pole	Thermal current ( $I_{th}$ ):	2 A
	Rated insulation voltage (U):	30 Vac 36 Vdc
	Protection against short circuits:	type gG fuse 2 A 500 V
	Pollution degree:	3
		Alternating current: AC15 (50±60 Hz)
		Ue (V) 250 400 500
		Ie (A) 6 4 1
		Direct current: DC13
		Ue (V) 24 125 250
		Ie (A) 3 0.55 0.3
		Alternating current: AC15 (50±60 Hz)
		Ue (V) 24 120 250
		Ie (A) 4 4 4
		Direct current: DC13
		Ue (V) 24 125 250
		Ie (A) 3 0.55 0.3
		Alternating current: AC15 (50±60 Hz)
		Ue (V) 24
		Ie (A) 2
		Direct current: DC13
		Ue (V) 24
		Ie (A) 2



### Features approved by IMQ

Rated insulation voltage (U<sub>i</sub>): 500 Vac  
 400 Vac (for contact blocks 2, 11, 12, 20, 21, 22, 28, 29, 30, 33, 34, 37)

Conventional free air thermal current (I<sub>th</sub>): 10 A

Protection against short circuits: type aM fuse 10 A 500 V

Rated impulse withstand voltage (U<sub>imp</sub>): 6 kV  
 4 kV (for contact blocks 20, 21, 22, 28, 29, 30, 33, 34)

Protection degree of the housing: IP67

MV terminals (screw terminals)

Pollution degree: 3

Utilization category: AC15

Operating voltage (U<sub>e</sub>): 400 Vac (50 Hz)

Operating current (I<sub>e</sub>): 3 A

Forms of the contact element: Za, Za+Za, X+X, Zb, Y+Y, Y+Y+X, Y+Y+Y, Y+X+X, Y, X.

Positive opening of contacts on contact blocks 5, 6, 7, 8, 9, 11, 13, 14, 16, 17, 18, 19, 20, 21, 22, 28, 29, 30, 33, 34, 37, 38, 39, 66.

In compliance with standards: EN 60947-1, EN 60947-5-1, fundamental requirements of the Low Voltage Directive 2014/35/EU.

Please contact our technical department for the list of approved products.

### Features approved by UL

Electrical Ratings: Q300 pilot duty (69 VA, 125-250 V dc)  
 A600 pilot duty (720 VA, 120-600 V ac)

Environmental Ratings: Types 1, 4X, 12, 13

For all contact blocks except 2 and 3 use 60 or 75°C copper (Cu) conductors, rigid or flexible, wire size 12, 14 AWG. Tightening torque for terminal screws of 7.1 lb in (0.8 Nm).

For contact blocks 2 and 3 use 60 or 75°C copper (Cu) conductors, rigid or flexible, wire size 14 AWG. Tightening torque for terminal screws of 12 lb in (1.4 Nm).

The hub is to be connected to the conduit before the hub is connected to the enclosure.

Please contact our technical department for the list of approved products.

### Wiring diagram for M12 connectors

Contact block 2 2x(1NO-1NC)	Contact block 5 1NO+1NC	Contact block 6 1NO+1NC	Contact block 7 1NO+1NC	Contact block 9 2NC	Contact block 10 2NO	Contact block 11 2NC	Contact block 12 2NO	Contact block 13 2NC	
M12 connector, 8-pole	M12 connector, 4-pole	M12 connector, 4-pole	M12 connector, 4-pole	M12 connector, 4-pole	M12 connector, 4-pole	M12 connector, 4-pole	M12 connector, 4-pole	M12 connector, 4-pole	
Contacts	Pin no.	Contacts	Pin no.	Contacts	Pin no.	Contacts	Pin no.	Contacts	Pin no.
NO	3-4	NC	1-2	NC	1-2	NC	1-2	NO	1-2
NC	5-6	NO	3-4	NO	3-4	NO	3-4	NC (1°)	1-2
NC	7-8							NO (2°)	3-4
NO	1-2								

Contact block 14 2NC	Contact block 15 2NO	Contact block 16 2NC	Contact block 18 1NO+1NC	Contact block 20 1NO+2NC	Contact block 21 3NC	Contact block 22 2NO+1NC	Contact block 33 1NO+1NC	Contact block 34 2NC		
M12 connector, 4-pole	M12 connector, 4-pole	M12 connector, 4-pole	M12 connector, 4-pole	M12 connector, 8-pole	M12 connector, 8-pole	M12 connector, 8-pole	M12 connector, 4-pole	M12 connector, 4-pole		
Contacts	Pin no.	Contacts	Pin no.	Contacts	Pin no.	Contacts	Pin no.	Contacts	Pin no.	
NC (1°)	1-2	NO (1°)	1-2	NC, lever to the right	1-2	NC	3-4	NC	1-2	
NC (2°)	3-4	NO (2°)	3-4	NC, lever to the left	3-4	NO	5-6	NO	3-4	
					NO	7-8	NC	7-8	NO	7-8

Contact block E1  
PNP

M12 connector, 4-pole

Contacts	Pin no.
+	1
-	3
NC	2
NO	4

# 2 FP series position switches

- Contact type
- R** = snap action
  - L** = slow action
  - LO** = slow action, make before break
  - LS** = slow action, shifted
  - LV** = slow action, shifted and spaced
  - LI** = slow action, independent
  - LA** = slow action, close
  -  = electronic, PNP

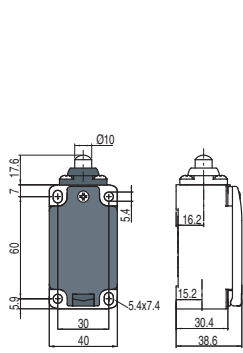

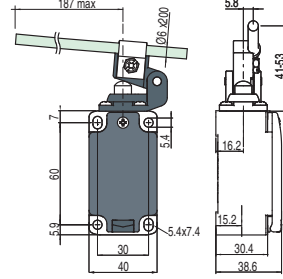
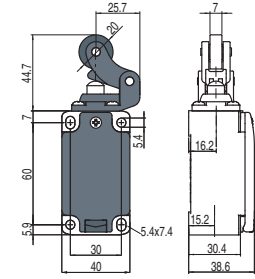

With steel roller with self-lubrication or 316L stainless steel on request

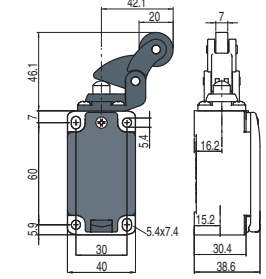

With steel roller with self-lubrication or 316L stainless steel on request



Contact block	FP 201-M2	2x(1NO-1NC)	FP 202-M2	2x(1NO-1NC)	FP 204-M2	2x(1NO-1NC)	FP 205-M2	2x(1NO-1NC)
2	<b>R</b>	FP 201-M2	2x(1NO-1NC)	FP 202-M2	2x(1NO-1NC)	FP 204-M2	2x(1NO-1NC)	FP 205-M2
5	<b>R</b>	FP 501-M2	1NO+1NC	FP 502-M2	1NO+1NC	FP 504-M2	1NO+1NC	FP 505-M2
6	<b>L</b>	FP 601-M2	1NO+1NC	FP 602-M2	1NO+1NC	FP 604-M2	1NO+1NC	FP 605-M2
7	<b>LO</b>	FP 701-M2	1NO+1NC	FP 702-M2	1NO+1NC	FP 704-M2	1NO+1NC	FP 705-M2
9	<b>L</b>	FP 901-M2	2NC	FP 902-M2	2NC	FP 904-M2	2NC	FP 905-M2
10	<b>L</b>	FP 1001-M2	2NO	FP 1002-M2	2NO	FP 1004-M2	2NO	FP 1005-M2
11	<b>R</b>	FP 1101-M2	2NC	FP 1102-M2	2NC	FP 1104-M2	2NC	FP 1105-M2
12	<b>R</b>	FP 1201-M2	2NO	FP 1202-M2	2NO	FP 1204-M2	2NO	FP 1205-M2
13	<b>LV</b>	FP 1301-M2	2NC	FP 1302-M2	2NC	FP 1304-M2	2NC	FP 1305-M2
14	<b>LS</b>	FP 1401-M2	2NC	FP 1402-M2	2NC	FP 1404-M2	2NC	FP 1405-M2
15	<b>LS</b>	FP 1501-M2	2NO	FP 1502-M2	2NO	FP 1504-M2	2NO	FP 1505-M2
18	<b>LA</b>	FP 1801-M2	1NO+1NC	FP 1802-M2	1NO+1NC	FP 1804-M2	1NO+1NC	FP 1805-M2
20	<b>L</b>	FP 2001-M2	1NO+2NC	FP 2002-M2	1NO+2NC	FP 2004-M2	1NO+2NC	FP 2005-M2
21	<b>L</b>	FP 2101-M2	3NC	FP 2102-M2	3NC	FP 2104-M2	3NC	FP 2105-M2
22	<b>L</b>	FP 2201-M2	2NO+1NC	FP 2202-M2	2NO+1NC	FP 2204-M2	2NO+1NC	FP 2205-M2
E1		FP E101-M2	1NO-1NC	FP E102-M2	1NO-1NC	FP E104-M2	1NO-1NC	FP E105-M2
Max. speed	page 229 - type 4		page 229 - type 3		0.5 m/s		page 229 - type 3	
Actuating force	8 N (25 N ⊕)		6 N (25 N ⊕)		0.17 Nm		6 N (25 N ⊕)	
Travel diagrams	page 230 - group 1		page 230 - group 2		page 230 - group 1		page 230 - group 2	

- Contact type
- R** = snap action
  - L** = slow action
  - LO** = slow action, make before break
  - LS** = slow action, shifted
  - LV** = slow action, shifted and spaced
  - LI** = slow action, independent
  - LA** = slow action, close
  -  = electronic, PNP

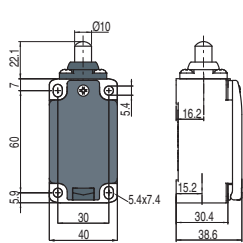

Rope switch for signalling

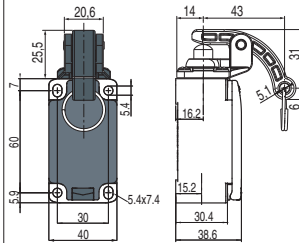

External gasket

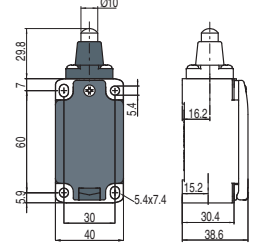
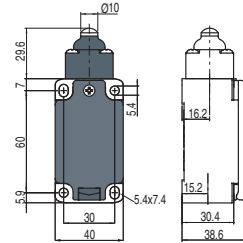

Contact block	FP 208-M2	2x(1NO-1NC)	FP 209-M2	2x(1NO-1NC)	FP 210-M2	2x(1NO-1NC)	FP 211-M2	2x(1NO-1NC)
2	<b>R</b>	FP 208-M2	2x(1NO-1NC)	FP 209-M2	2x(1NO-1NC)	FP 210-M2	2x(1NO-1NC)	FP 211-M2
5	<b>R</b>	FP 508-M2	1NO+1NC	FP 509-M2	1NO+1NC	FP 510-M2	1NO+1NC	FP 511-M2
6	<b>L</b>	FP 608-M2	1NO+1NC	FP 609-M2	1NO+1NC	FP 610-M2	1NO+1NC	FP 611-M2
7	<b>LO</b>	FP 708-M2	1NO+1NC	FP 709-M2	1NO+1NC	FP 710-M2	1NO+1NC	FP 711-M2
9	<b>L</b>	FP 908-M2	2NC	FP 909-M2	2NC	FP 910-M2	2NC	FP 911-M2
10	<b>L</b>	FP 1008-M2	2NO	FP 1009-M2	2NO	FP 1010-M2	2NO	FP 1011-M2
11	<b>R</b>	FP 1108-M2	2NC	FP 1109-M2	2NC	FP 1110-M2	2NC	FP 1111-M2
12	<b>R</b>	FP 1208-M2	2NO	FP 1209-M2	2NO	FP 1210-M2	2NO	FP 1211-M2
13	<b>LV</b>	FP 1308-M2	2NC	FP 1309-M2	2NC	FP 1310-M2	2NC	FP 1311-M2
14	<b>LS</b>	FP 1408-M2	2NC	FP 1409-M2	2NC	FP 1410-M2	2NC	FP 1411-M2
15	<b>LS</b>	FP 1508-M2	2NO	FP 1509-M2	2NO	FP 1510-M2	2NO	FP 1511-M2
18	<b>LA</b>	FP 1808-M2	1NO+1NC	FP 1809-M2	1NO+1NC	FP 1810-M2	1NO+1NC	FP 1811-M2
20	<b>L</b>	FP 2008-M2	1NO+2NC	FP 2009-M2	1NO+2NC	FP 2010-M2	1NO+2NC	FP 2011-M2
21	<b>L</b>	FP 2108-M2	3NC	FP 2109-M2	3NC	FP 2110-M2	3NC	FP 2111-M2
22	<b>L</b>	FP 2208-M2	2NO+1NC	FP 2209-M2	2NO+1NC	FP 2210-M2	2NO+1NC	FP 2211-M2
E1		FP E108-M2	1NO-1NC	FP E109-M2	1NO-1NC	FP E110-M2	1NO-1NC	FP E111-M2
Max. speed	page 229 - type 4		0.5 m/s		page 229 - type 4		page 229 - type 4	
Actuating force	8 N (25 N ⊕)		7 N		11 N (25 N ⊕)		8 N (25 N ⊕)	
Travel diagrams	page 230 - group 1		/		page 230 - group 1		page 230 - group 1	

All values in the drawings are in mm



Contact type	External gasket		Ball, Ø 8 mm, stainless steel		Ball, Ø 12.7 mm, stainless steel				
	<ul style="list-style-type: none"> <li><b>R</b> = snap action</li> <li><b>L</b> = slow action</li> <li><b>LO</b> = slow action, make before break</li> <li><b>LS</b> = slow action, shifted</li> <li><b>LV</b> = slow action, shifted and spaced</li> <li><b>LI</b> = slow action, independent</li> <li><b>LA</b> = slow action, close</li> <li><b>Λ</b> = electronic, PNP</li> </ul>								
Contact block									
2	<b>R</b>	FP 215-M2	2x(1NO-1NC)	FP 216-M2	2x(1NO-1NC)	FP 218-M2	2x(1NO-1NC)	FP 219-M2	2x(1NO-1NC)
5	<b>R</b>	FP 515-M2	⊕ 1NO+1NC	FP 516-M2	⊕ 1NO+1NC	FP 518-M2	⊕ 1NO+1NC	FP 519-M2	⊕ 1NO+1NC
6	<b>L</b>	FP 615-M2	⊕ 1NO+1NC	FP 616-M2	⊕ 1NO+1NC	FP 618-M2	⊕ 1NO+1NC	FP 619-M2	⊕ 1NO+1NC
7	<b>LO</b>	FP 715-M2	⊕ 1NO+1NC	FP 716-M2	⊕ 1NO+1NC	FP 718-M2	⊕ 1NO+1NC	FP 719-M2	⊕ 1NO+1NC
9	<b>L</b>	FP 915-M2	⊕ 2NC	FP 916-M2	⊕ 2NC	FP 918-M2	⊕ 2NC	FP 919-M2	⊕ 2NC
10	<b>L</b>	FP 1015-M2	2NO	FP 1016-M2	2NO	FP 1018-M2	2NO	FP 1019-M2	2NO
11	<b>R</b>	FP 1115-M2	⊕ 2NC	FP 1116-M2	⊕ 2NC	FP 1118-M2	⊕ 2NC	FP 1119-M2	⊕ 2NC
12	<b>R</b>	FP 1215-M2	2NO	FP 1216-M2	2NO	FP 1218-M2	2NO	FP 1219-M2	2NO
13	<b>LV</b>	FP 1315-M2	⊕ 2NC	FP 1316-M2	⊕ 2NC	FP 1318-M2	⊕ 2NC	FP 1319-M2	⊕ 2NC
14	<b>LS</b>	FP 1415-M2	⊕ 2NC	FP 1416-M2	⊕ 2NC	FP 1418-M2	⊕ 2NC	FP 1419-M2	⊕ 2NC
15	<b>LS</b>	FP 1515-M2	2NO	FP 1516-M2	2NO	FP 1518-M2	2NO	FP 1519-M2	2NO
18	<b>LA</b>	FP 1815-M2	⊕ 1NO+1NC	FP 1816-M2	⊕ 1NO+1NC	FP 1818-M2	⊕ 1NO+1NC	FP 1819-M2	⊕ 1NO+1NC
20	<b>L</b>	FP 2015-M2	⊕ 1NO+2NC	FP 2016-M2	⊕ 1NO+2NC	FP 2018-M2	⊕ 1NO+2NC	FP 2019-M2	⊕ 1NO+2NC
21	<b>L</b>	FP 2115-M2	⊕ 3NC	FP 2116-M2	⊕ 3NC	FP 2118-M2	⊕ 3NC	FP 2119-M2	⊕ 3NC
22	<b>L</b>	FP 2215-M2	⊕ 2NO+1NC	FP 2216-M2	⊕ 2NO+1NC	FP 2218-M2	⊕ 2NO+1NC	FP 2219-M2	⊕ 2NO+1NC
E1	<b>Λ</b>	FP E115-M2	1NO-1NC	FP E116-M2	1NO-1NC	FP E118-M2	1NO-1NC	FP E119-M2	1NO-1NC
Max. speed	page 229 - type 2		page 229 - type 2		page 229 - type 4		page 229 - type 4		
Actuating force	11 N (25 N ⊕)		8 N (25 N ⊕)		8 N (25 N ⊕)		8 N (25 N ⊕)		
Travel diagrams	page 230 - group 1		page 230 - group 1		page 230 - group 1		page 230 - group 1		

Contact type	External gasket		External gasket		External gasket		Other rollers available. See page 34		
	<ul style="list-style-type: none"> <li><b>R</b> = snap action</li> <li><b>L</b> = slow action</li> <li><b>LO</b> = slow action, make before break</li> <li><b>LS</b> = slow action, shifted</li> <li><b>LV</b> = slow action, shifted and spaced</li> <li><b>LI</b> = slow action, independent</li> <li><b>LA</b> = slow action, close</li> <li><b>Λ</b> = electronic, PNP</li> </ul>								
Contact block									
2	<b>R</b>	FP 220-M2	2x(1NO-1NC)	FP 221-M2	2x(1NO-1NC)	FP 225-M2	2x(1NO-1NC)	FP 231-M2	2x(1NO-1NC)
5	<b>R</b>	FP 520-M2	1NO+1NC	FP 521-M2	1NO+1NC	FP 525-M2	1NO+1NC	FP 531-M2	⊕ 1NO+1NC
6	<b>L</b>	/	/	/	/	/	FP 631-M2	⊕ 1NO+1NC	
7	<b>LO</b>	/	/	/	/	/	FP 731-M2	⊕ 1NO+1NC	
9	<b>L</b>	/	/	/	/	/	FP 931-M2	⊕ 2NC	
10	<b>L</b>	FP 1020-M2	2NO	FP 1021-M2	2NO	FP 1025-M2	2NO	FP 1031-M2	2NO
11	<b>R</b>	/	/	/	/	/	FP 1131-M2	⊕ 2NC	
12	<b>R</b>	/	/	/	/	/	FP 1231-M2	2NO	
13	<b>LV</b>	/	/	/	/	/	FP 1331-M2	⊕ 2NC	
14	<b>LS</b>	/	/	/	/	/	FP 1431-M2	⊕ 2NC	
15	<b>LS</b>	/	/	/	/	/	FP 1531-M2	2NO	
16	<b>LI</b>	/	/	/	/	/	FP 1631-M2	⊕ 2NC	
18	<b>LA</b>	FP 1820-M2	1NO+1NC	FP 1821-M2	1NO+1NC	FP 1825-M2	1NO+1NC	FP 1831-M2	⊕ 1NO+1NC
20	<b>L</b>	FP 2020-M2	1NO+2NC	FP 2021-M2	1NO+2NC	FP 2025-M2	1NO+2NC	FP 2031-M2	⊕ 1NO+2NC
21	<b>L</b>	FP 2120-M2	3NC	FP 2121-M2	3NC	FP 2125-M2	3NC	FP 2131-M2	⊕ 3NC
22	<b>L</b>	FP 2220-M2	2NO+1NC	FP 2221-M2	2NO+1NC	FP 2225-M2	2NO+1NC	FP 2231-M2	⊕ 2NO+1NC
E1	<b>Λ</b>	FP E120-M2	1NO-1NC	FP E121-M2	1NO-1NC	FP E125-M2	1NO-1NC	FP E131-M2	1NO-1NC
Max. speed	1 m/s		1 m/s		1 m/s		page 229 - type 1		
Actuating force	0.09 Nm		0.08 Nm		0.14 Nm		0.1 Nm (0.25 Nm ⊕)		
Travel diagrams	page 230 - group 3		page 230 - group 3		page 230 - group 3		page 230 - group 4		

All values in the drawings are in mm

Accessories See page 207

➔ The 2D and 3D files are available at [www.pizzato.com](http://www.pizzato.com)

# FP series position switches

- Contact type
- R** = snap action
  - L** = slow action
  - LO** = slow action, make before break
  - LS** = slow action, shifted
  - LV** = slow action, shifted and spaced
  - LI** = slow action, independent
  - LA** = slow action, close
  - ⏏** = electronic, PNP

Contact block

		Round rod, Ø 3 mm, stainless steel	Square rod, 3x3 mm			Other rollers available. See page 34			
2	<b>R</b>	FP 232-M2	2x(1NO-1NC)	FP 233-M2	2x(1NO-1NC)	FP 234-M2	2x(1NO-1NC)	FP 235-M2	2x(1NO-1NC)
5	<b>R</b>	FP 532-M2	1NO+1NC	FP 533-M2	1NO+1NC	FP 534-M2	1NO+1NC	FP 535-M2	⊕ <sup>(1)</sup> 1NO+1NC
6	<b>L</b>	FP 632-M2	1NO+1NC	FP 633-M2	1NO+1NC	FP 634-M2	1NO+1NC	FP 635-M2	⊕ <sup>(1)</sup> 1NO+1NC
7	<b>LO</b>	FP 732-M2	1NO+1NC	FP 733-M2	1NO+1NC	FP 734-M2	1NO+1NC	FP 735-M2	⊕ <sup>(1)</sup> 1NO+1NC
9	<b>L</b>	FP 932-M2	2NC	FP 933-M2	2NC	FP 934-M2	2NC	FP 935-M2	⊕ <sup>(1)</sup> 2NC
10	<b>L</b>	FP 1032-M2	2NO	FP 1033-M2	2NO	FP 1034-M2	2NO	FP 1035-M2	2NO
11	<b>R</b>	FP 1132-M2	2NC	FP 1133-M2	2NC	FP 1134-M2	2NC	FP 1135-M2	⊕ <sup>(1)</sup> 2NC
12	<b>R</b>	FP 1232-M2	2NO	FP 1233-M2	2NO	FP 1234-M2	2NO	FP 1235-M2	2NO
13	<b>LV</b>	FP 1332-M2	2NC	FP 1333-M2	2NC	FP 1334-M2	2NC	FP 1335-M2	⊕ <sup>(1)</sup> 2NC
14	<b>LS</b>	FP 1432-M2	2NC	FP 1433-M2	2NC	FP 1434-M2	2NC	FP 1435-M2	⊕ <sup>(1)</sup> 2NC
15	<b>LS</b>	FP 1532-M2	2NO	FP 1533-M2	2NO	FP 1534-M2	2NO	FP 1535-M2	2NO
16	<b>LI</b>	FP 1632-M2	2NC	FP 1633-M2	2NC	FP 1634-M2	2NC	FP 1635-M2	⊕ <sup>(1)</sup> 2NC
18	<b>LA</b>	FP 1832-M2	1NO+1NC	FP 1833-M2	1NO+1NC	FP 1834-M2	1NO+1NC	FP 1835-M2	⊕ <sup>(1)</sup> 1NO+1NC
20	<b>L</b>	FP 2032-M2	1NO+2NC	FP 2033-M2	1NO+2NC	FP 2034-M2	1NO+2NC	FP 2035-M2	⊕ <sup>(1)</sup> 1NO+2NC
21	<b>L</b>	FP 2132-M2	3NC	FP 2133-M2	3NC	FP 2134-M2	3NC	FP 2135-M2	⊕ <sup>(1)</sup> 3NC
22	<b>L</b>	FP 2232-M2	2NO+1NC	FP 2233-M2	2NO+1NC	FP 2234-M2	2NO+1NC	FP 2235-M2	⊕ <sup>(1)</sup> 2NO+1NC
E1	<b>⏏</b>	FP E132-M2	1NO-1NC	FP E133-M2	1NO-1NC	FP E134-M2	1NO-1NC	FP E135-M2	1NO-1NC
Max. speed		1.5 m/s		1.5 m/s		1 m/s		page 229 - type 1	
Actuating force		0.1 Nm		0.1 Nm		0.1 Nm		0.1 Nm (0.25 Nm ⊕)	
Travel diagrams		page 230 - group 4		page 230 - group 4		page 230 - group 4		page 230 - group 4	

- Contact type
- R** = snap action
  - L** = slow action
  - LO** = slow action, make before break
  - LS** = slow action, shifted
  - LV** = slow action, shifted and spaced
  - LI** = slow action, independent
  - LA** = slow action, close
  - ⏏** = electronic, PNP

Contact block

		Glass fibre rod	Other rollers available. See page 34	Other rollers available. See page 34		Porcelain roller			
2	<b>R</b>	FP 236-M2	2x(1NO-1NC)	FP 251-M2	2x(1NO-1NC)	FP 252-M2	2x(1NO-1NC)	FP 253-E11M2	2x(1NO-1NC)
5	<b>R</b>	FP 536-M2	1NO+1NC	FP 551-M2	⊕ <sup>(1)</sup> 1NO+1NC	FP 552-M2	⊕ <sup>(1)</sup> 1NO+1NC	FP 553-E11M2V9	⊕ <sup>(1)</sup> 1NO+1NC
6	<b>L</b>	FP 636-M2	1NO+1NC	FP 651-M2	⊕ <sup>(1)</sup> 1NO+1NC	FP 652-M2	⊕ <sup>(1)</sup> 1NO+1NC	FP 653-E11M2V9	⊕ <sup>(1)</sup> 1NO+1NC
7	<b>LO</b>	FP 736-M2	1NO+1NC	FP 751-M2	⊕ <sup>(1)</sup> 1NO+1NC	FP 752-M2	⊕ <sup>(1)</sup> 1NO+1NC	FP 753-E11M2V9	⊕ <sup>(1)</sup> 1NO+1NC
9	<b>L</b>	FP 936-M2	2NC	FP 951-M2	⊕ <sup>(1)</sup> 2NC	FP 952-M2	⊕ <sup>(1)</sup> 2NC	FP 953-E11M2V9	⊕ <sup>(1)</sup> 2NC
10	<b>L</b>	FP 1036-M2	2NO	FP 1051-M2	2NO	FP 1052-M2	2NO	FP 1053-E11M2V9	2NO
11	<b>R</b>	FP 1136-M2	2NC	FP 1151-M2	⊕ <sup>(1)</sup> 2NC	FP 1152-M2	⊕ <sup>(1)</sup> 2NC	/	/
12	<b>R</b>	FP 1236-M2	2NO	FP 1251-M2	2NO	FP 1252-M2	2NO	FP 1253-E11M2V9	2NO
13	<b>LV</b>	FP 1336-M2	2NC	FP 1351-M2	⊕ <sup>(1)</sup> 2NC	FP 1352-M2	⊕ <sup>(1)</sup> 2NC	FP 1353-E11M2V9	⊕ <sup>(1)</sup> 2NC
14	<b>LS</b>	FP 1436-M2	2NC	FP 1451-M2	⊕ <sup>(1)</sup> 2NC	FP 1452-M2	⊕ <sup>(1)</sup> 2NC	FP 1453-E11M2V9	⊕ <sup>(1)</sup> 2NC
15	<b>LS</b>	FP 1536-M2	2NO	FP 1551-M2	2NO	FP 1552-M2	2NO	FP 1553-E11M2V9	2NO
16	<b>LI</b>	FP 1636-M2	2NC	/	/	/	/	/	/
18	<b>LA</b>	FP 1836-M2	1NO+1NC	FP 1851-M2	⊕ <sup>(1)</sup> 1NO+1NC	FP 1852-M2	⊕ <sup>(1)</sup> 1NO+1NC	FP 1853-E11M2V9	⊕ <sup>(1)</sup> 1NO+1NC
20	<b>L</b>	FP 2036-M2	1NO+2NC	FP 2051-M2	⊕ <sup>(1)</sup> 1NO+2NC	FP 2052-M2	⊕ <sup>(1)</sup> 1NO+2NC	FP 2053-E11M2V9	⊕ <sup>(1)</sup> 1NO+2NC
21	<b>L</b>	FP 2136-M2	3NC	FP 2151-M2	⊕ <sup>(1)</sup> 3NC	FP 2152-M2	⊕ <sup>(1)</sup> 3NC	FP 2153-E11M2V9	⊕ <sup>(1)</sup> 3NC
22	<b>L</b>	FP 2236-M2	2NO+1NC	FP 2251-M2	⊕ <sup>(1)</sup> 2NO+1NC	FP 2252-M2	⊕ <sup>(1)</sup> 2NO+1NC	FP 2253-E11M2V9	⊕ <sup>(1)</sup> 2NO+1NC
E1	<b>⏏</b>	FP E136-M2	1NO-1NC	FP E151-M2	1NO-1NC	FP E152-M2	1NO-1NC	FP E153-E11M2V9	1NO-1NC
Max. speed		1.5 m/s		page 229 - type 1		page 229 - type 1		0.5 m/s	
Actuating force		0.1 Nm		0.06 Nm (0.25 Nm ⊕)		0.06 Nm (0.25 Nm ⊕)		0.03 Nm (0.25 Nm ⊕)	
Travel diagrams		page 230 - group 4		page 230 - group 4		page 230 - group 4		page 230 - group 5	

<sup>(1)</sup> Positive opening only with actuator set to max. See page 34.

All values in the drawings are in mm

Accessories See page 207

→ The 2D and 3D files are available at [www.pizzato.com](http://www.pizzato.com)





Contact type	Other rollers available. See page 34		Other rollers available. See page 34		With steel roller with self-lubrication or 316L stainless steel on request	With steel roller with self-lubrication or 316L stainless steel on request			
2		FP 256-M2	2x(1NO-1NC)	FP 257-M2	2x(1NO-1NC)	/	/		
5		FP 556-M2	1NO+1NC	FP 557-M2	1NO+1NC	FP 541-M2	1NO+1NC	FP 542-M2	1NO+1NC
6		FP 656-M2	1NO+1NC	FP 657-M2	1NO+1NC	Bistable switch with lyra lever, single track		Bistable switch with lyra lever, dual track	
7		FP 756-M2	1NO+1NC	FP 757-M2	1NO+1NC				
9		FP 956-M2	2NC	FP 957-M2	2NC	0 45° 65° 80° 90° 25° S		0 45° 65° 80° 90° 25° S	
10		FP 1056-M2	2NO	FP 1057-M2	2NO	S = mechanical switching point positive opening on contacts 21-22 only		S = mechanical switching point positive opening on contacts 21-22 only	
11		FP 1156-M2	2NC	FP 1157-M2	2NC				
12		FP 1256-M2	2NO	FP 1257-M2	2NO				
13		FP 1356-M2	2NC	FP 1357-M2	2NC				
14		FP 1456-M2	2NC	FP 1457-M2	2NC				
15		FP 1556-M2	2NO	FP 1557-M2	2NO				
16		FP 1656-M2	2NC	FP 1657-M2	2NC				
18		FP 1856-M2	1NO+1NC	FP 1857-M2	1NO+1NC				
20		FP 2056-M2	1NO+2NC	FP 2057-M2	1NO+2NC				
21		FP 2156-M2	3NC	FP 2157-M2	3NC				
22		FP 2256-M2	2NO+1NC	FP 2257-M2	2NO+1NC				
E1		FP E156-M2	1NO-1NC	FP E157-M2	1NO-1NC				
Max. speed	page 229 - type 1		page 229 - type 1		0.5 m/s with cam at 30°		0.5 m/s with cam at 30°		
Actuating force	0.1 Nm (0.25 Nm )		0.1 Nm (0.25 Nm )		0.21 Nm (0.36 Nm )		0.21 Nm (0.36 Nm )		
Travel diagrams	page 230 - group 4		page 230 - group 4		/		/		

Contact type	Rope switch for signalling		
2		FP 276-M2	2x(1NO-1NC)
5		FP 576-M2	1NO+1NC
6		FP 676-M2	1NO+1NC
7		FP 776-M2	1NO+1NC
9		FP 976-M2	2NO
10		FP 1076-M2	2NC
11		FP 1176-M2	2NO
12		FP 1276-M2	2NC
13		FP 1376-M2	2NO
14		FP 1476-M2	2NO
15		FP 1576-M2	2NC
16		/	
18		FP 1876-M2	1NO+1NC
20		FP 2076-M2	2NO+1NC
21		FP 2176-M2	3NO
22		FP 2276-M2	1NO+2NC
E1		/	
Max. speed	0.5 m/s		
Actuating force	initial 20 N - final 40 N		
Travel diagrams	page 230 - group 6		

All values in the drawings are in mm

Accessories See page 207

→ The 2D and 3D files are available at [www.pizzato.com](http://www.pizzato.com)

## Position switches with swivelling lever without actuator

- Contact type
- R** = snap action
  - L** = slow action
  - LO** = slow action, make before break
  - LS** = slow action, shifted
  - LV** = slow action, shifted and spaced
  - LI** = slow action, independent
  - LA** = slow action, close
  - A** = electronic, PNP

Contact block

	Regular head		Compact head		
2	<b>R</b>	FP 238-M2	2x(1NO-1NC)	FP 258-M2	2x(1NO-1NC)
5	<b>R</b>	FP 538-M2	1NO+1NC	FP 558-M2	1NO+1NC
6	<b>L</b>	FP 638-M2	1NO+1NC	FP 658-M2	1NO+1NC
7	<b>LO</b>	FP 738-M2	1NO+1NC	FP 758-M2	1NO+1NC
9	<b>L</b>	FP 938-M2	2NC	FP 958-M2	2NC
10	<b>L</b>	FP 1038-M2	2NO	FP 1058-M2	2NO
11	<b>R</b>	FP 1138-M2	2NC	FP 1158-M2	2NC
12	<b>R</b>	FP 1238-M2	2NO	FP 1258-M2	2NO
13	<b>LV</b>	FP 1338-M2	2NC	FP 1358-M2	2NC
14	<b>LS</b>	FP 1438-M2	2NC	FP 1458-M2	2NC
15	<b>LS</b>	FP 1538-M2	2NO	FP 1558-M2	2NO
16	<b>LI</b>	FP 1638-M2	2NC	/	/
18	<b>LA</b>	FP 1838-M2	1NO+1NC	FP 1858-M2	1NO+1NC
20	<b>L</b>	FP 2038-M2	1NO+2NC	FP 2058-M2	1NO+2NC
21	<b>L</b>	FP 2138-M2	3NC	FP 2158-M2	3NC
22	<b>L</b>	FP 2238-M2	2NO+1NC	FP 2258-M2	2NO+1NC
E1	<b>A</b>	FP E138-M2	1NO-1NC	FP E158-M2	1NO-1NC
Actuating force	0.1 Nm (0.25 Nm $\rightarrow$ )		0.06 Nm (0.25 Nm $\rightarrow$ )		0.21 Nm (0.36 Nm $\rightarrow$ )
Travel diagrams	page 230 - group 4		page 230 - group 4		/

**IMPORTANT**  
**For safety applications:** join only switches and actuators marked with symbol  $\rightarrow$  next to the product code.

For more information about safety applications see details on page 225.

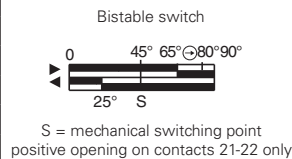

## Separate actuators

**IMPORTANT:** These separate actuators can be used only with items of the FD, FP, FL, FC series.

Technopolymer roller Ø 20 mm	Adjustable round rod Ø 3x125 mm	Adjustable square rod, 3x3x125 mm	Spring rod with plastic tip	Adjustable actuator with technopolymer roller	Adjustable glass fibre rod	
VF L31 $\rightarrow$	VF L32 $\rightarrow$ (3)	VF L33 $\rightarrow$ (3)	VF L34	VF L35 $\rightarrow$ (1) (3)	VF L36 $\rightarrow$ (3)	
Lyra actuator, single track	Lyra actuator, dual track	Technopolymer roller, Ø 20 mm	Technopolymer roller, Ø 20 mm	Porcelain roller	Adjustable safety actuator with technopolymer roller	Technopolymer roller, Ø 20 mm
VF L41 $\rightarrow$	VF L42 $\rightarrow$	VF L51 $\rightarrow$	VF L52 $\rightarrow$	VF L53 $\rightarrow$ (2)	VF L56 $\rightarrow$ (3)	VF L57 $\rightarrow$

All values in the drawings are in mm

Accessories See page 207

$\rightarrow$  The 2D and 3D files are available at [www.pizzato.com](http://www.pizzato.com)



## Special separate actuators

**IMPORTANT:** These separate actuators can be used only with items of the FD, FP, FL, FC series.

Steel rollers, Ø 20 mm, with self-lubrication

VF L31-R24 (1) (3)	VF L35-R24 (1) (3)	VF L51-R24 (1) (3)	VF L52-R24 (1) (3)	VF L56-R24 (1) (3)	VF L57-R24 (1) (3)

**Note:** To order with 316L stainless steel roller: replace R24 with R41 in the order numbers.

Technopolymer rollers, Ø 35 mm

VF L31-R25 (1) (3) (4)	VF L35-R25 (1) (3) (4)	VF L51-R25 (1) (3) (4)	VF L52-R25 (1) (3) (4)	VF L56-R25 (1) (3) (4)	VF L57-R25 (1) (3) (4)

Rubber rollers, Ø 40 mm

VF L31-R5 (1) (3) (4)	VF L35-R5 (1) (3) (4)	VF L51-R5 (1) (3) (4)	VF L52-R5 (1) (3) (4)	VF L56-R5 (1) (3) (4)	VF L57-R5 (1) (3) (4)

Rubber rollers, Ø 50 mm

VF L31-R26 (1) (3) (4)	VF L35-R26 (1) (3) (4)	VF L51-R26 (1) (3) (4)	VF L52-R26 (1) (3) (4)	VF L56-R26 (1) (3) (4)	VF L57-R26 (1) (3) (4)

Protruding rubber rollers, Ø 50 mm

VF L35-R27 (1) (3)	VF L56-R27 (1) (3)

- (1) Lever VF L35 can only be used in safety applications if adjusted to its max. length, as shown in the figure to the right. If an adjustable lever is required for safety applications, use the VF L56 adjustable safety lever.
- (2) The position switch obtained by assembling switch FP •58-M2 (e.g. FP 558-M2, FP 658-M2, ...) with actuator VF L53 will not present the same travel diagrams and actuating forces as switch FP •53-E11M2V9 (e.g. FP 553-E11M2V9, FP 653-E11M2V9, ...)
- (3) If installed with switch FP •58-M2 (e.g. FP 558-M2, FP 658-M2, ...) the actuator may hit the housing of the switch upon actuation. This possible interference depends on the fixing position of actuator and switch head.
- (4) The actuator cannot be rotated to the inside because it will hit the switch head upon actuation.

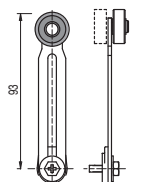

All values in the drawings are in mm

Accessories See page 207

→ The 2D and 3D files are available at [www.pizzato.com](http://www.pizzato.com)

## Selection diagram

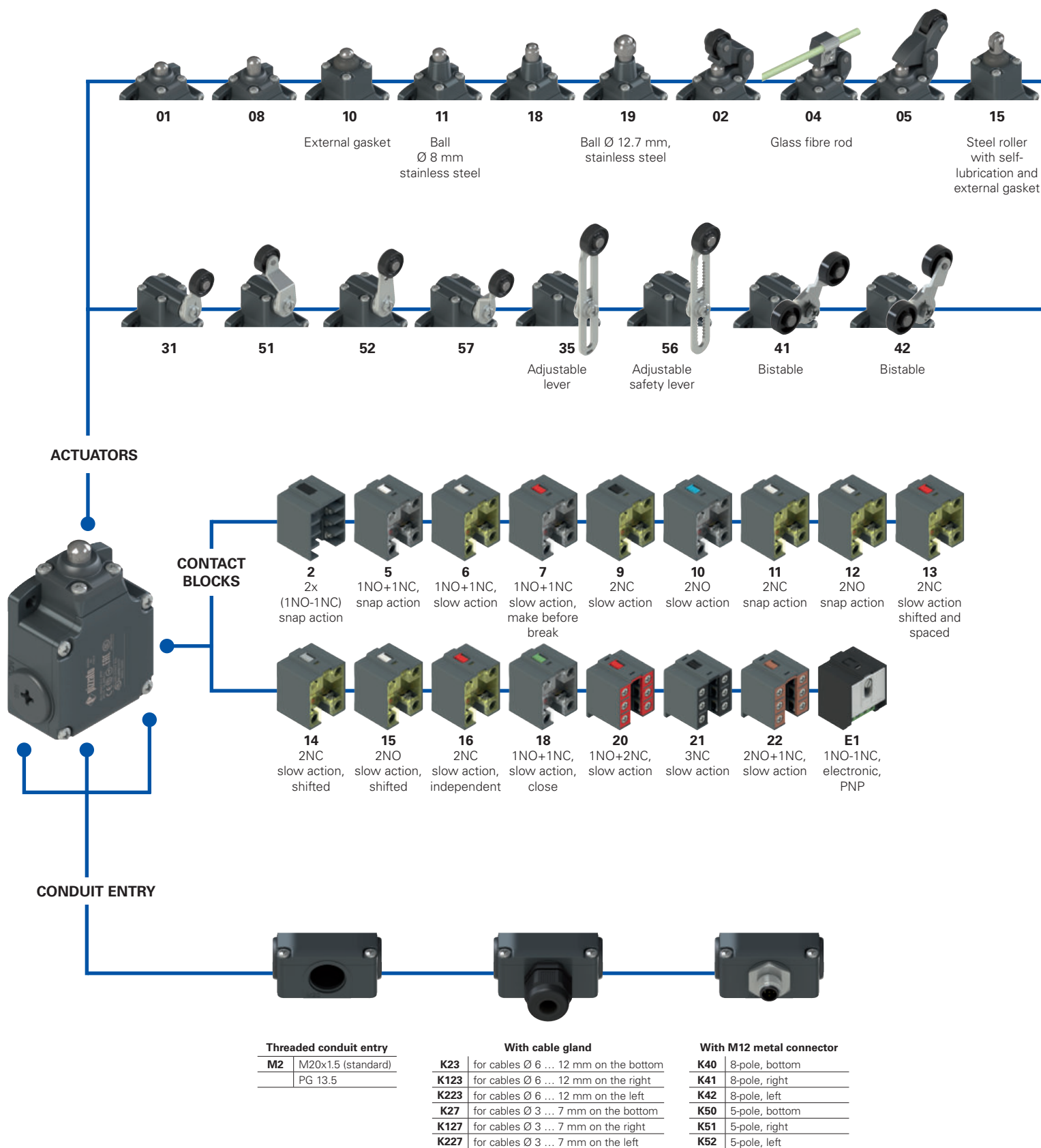

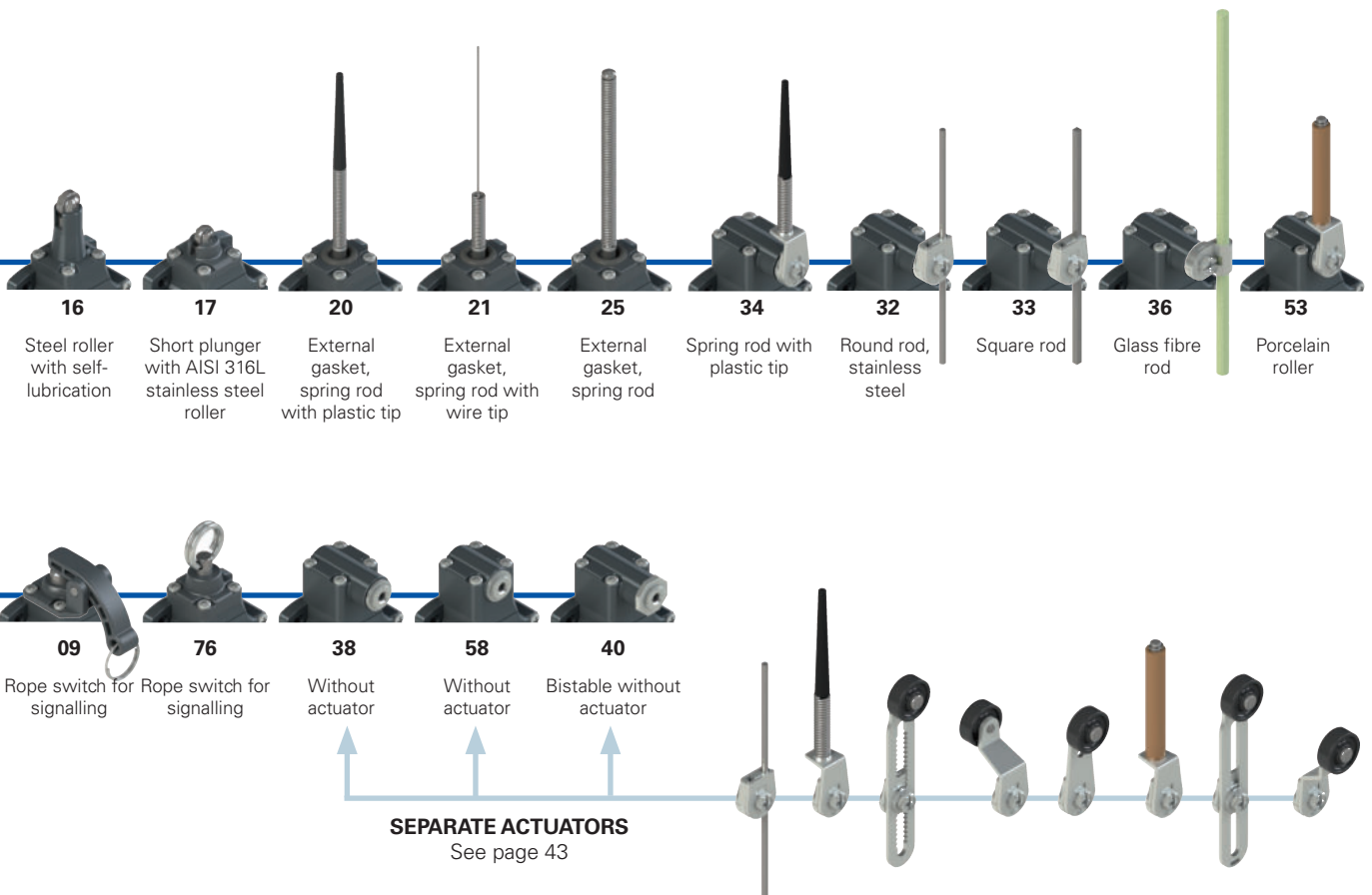
**Code structure**
**Attention!** The feasibility of a code number does not mean the effective availability of a product. Please contact our sales office.

article
options
options  
**FL 502-GM2K50R24T6**

Housing	
<b>FL</b>	metal, three conduit entries

Contact block	
<b>5</b>	1NO+1NC, snap action
<b>6</b>	1NO+1NC, slow action
<b>7</b>	1NO+1NC, slow action, make before break
...	...

Actuators	
<b>01</b>	short plunger
<b>02</b>	roller lever
<b>05</b>	angled lever with roller
...	...

Contact type	
	silver contacts (standard)
<b>G</b>	silver contacts, 1 µm gold coating
<b>G1</b>	silver contacts, 2.5 µm gold coating (not for contact block 2, 20, 21, 22)

Threaded conduit entry	
<b>M2</b>	M20x1.5 (standard)
	PG 13.5

Ambient temperature	
	-25°C ... +80°C (standard)
<b>T6</b>	-40°C ... +80°C

Rollers	
	standard roller
<b>R24</b>	Steel, with self-lubrication, Ø 20 mm (for actuators 02, 05, 31, 35, 51, 52, 56, 57)
<b>R41</b>	316L stainless steel, Ø 20 mm (for actuators 02, 05, 31, 35, 51, 52, 56, 57)
<b>R25</b>	technopolymer, Ø 35 mm (for actuators 31, 35, 51, 52, 56, 57)
<b>R5</b>	rubber, Ø 40 mm (for actuators 31, 35, 51, 52, 56, 57)
<b>R26</b>	rubber, Ø 50 mm (for actuators 31, 35, 51, 52, 56, 57)
<b>R27</b>	rubber, protruding, Ø 50 mm (for actuators 35 and 56)

Pre-installed cable glands or connectors	
	no cable gland or connector (standard)
<b>K23</b>	cable gland for cables Ø 6 ... 12 mm
<b>K50</b>	M12 metal connector, 5-pole

For the complete list of possible combinations please contact our technical department.



### Main features

- Metal housing, three conduit entries
- Protection degree IP67
- 17 contact blocks available
- 29 actuators available
- Versions with M12 connector
- Versions with gold-plated silver contacts

### Technical data

#### Housing

Metal housing, powder-coated  
 Three threaded conduit entries: M20x1.5 (standard)  
 Protection degree acc. to EN 60529: IP67 with cable gland of equal or higher protection degree

#### General data

Ambient temperature: -25°C ... +80°C (standard)  
 -40°C ... +80°C (T6 option)  
 Max. actuation frequency: 3600 operating cycles/hour  
 Mechanical endurance: 20 million operating cycles  
 Mounting position: any  
 Safety parameter  $B_{10D}$ : 40,000,000 for NC contacts  
 Mechanical interlock, not coded: type 1 acc. to EN ISO 14119  
 Tightening torques for installation: see page 229  
 Wire cross-sections and wire stripping lengths: see page 249

#### In compliance with standards:

IEC 60947-5-1, EN 60947-5-1, EN 60947-1, IEC 60204-1, EN 60204-1, EN ISO 14119, EN ISO 12100, IEC 60529, EN 60529, EN IEC 63000, UL 508, CSA C22.2 No. 14.

#### Approvals:

IEC 60947-5-1, UL 508, CSA C22.2 No. 14, GB/T14048.5.

#### Compliance with the requirements of:

Low Voltage Directive 2014/35/EU, EMC Directive 2014/30/EU, RoHS Directive 2011/65/EU.

#### Positive contact opening in conformity with standards:

IEC 60947-5-1, EN 60947-5-1.

### Quality marks:



IMQ approval: EG605  
 UL approval: E131787  
 CCC approval: 2021000305000099  
 EAC approval: RU C-IT.YT03.B.00035/19

### Installation for safety applications:

Use only switches marked with the  $\ominus$  symbol beside the product code. Always connect the safety circuit to the **NC contacts** (normally closed contacts: 11-12, 21-22 or 31-32) as required by **EN ISO 14119, paragraph 5.4** for specific interlock applications and **EN ISO 13849-2 tables D3** (well-tried components) and **D.8** (fault exclusions) for safety applications in general. Actuate the switch **at least up to the positive opening travel** shown in the travel diagrams on page 230. Actuate the switch **at least with the positive opening force**, reported in brackets below each article, next to the actuating force value.

**⚠ If not expressly indicated in this chapter, for correct installation and utilization of all articles see the instructions given on pages 227 to 242.**

	Electrical data	Utilization category
without connector	Thermal current ( $I_{th}$ ):	10 A
	Rated insulation voltage (U):	500 Vac 600 Vdc 400 Vac 500 Vdc (contact blocks 2, 11, 12, 20, 21, 22)
	Rated impulse withstand voltage ( $U_{imp}$ ):	6 kV 4 kV (contact blocks 20, 21, 22)
	Conditional short circuit current: Protection against short circuits: Pollution degree:	1000 A acc. to EN 60947-5-1 type aM fuse 10 A 500 V 3
with M12 connector, 5-pole	Thermal current ( $I_{th}$ ):	4 A
	Rated insulation voltage (U):	250 Vac 300 Vdc
	Protection against short circuits: Pollution degree:	type gG fuse 4 A 500 V 3
		Alternating current: AC15 (50±60 Hz) Ue (V) 24 120 250 Ie (A) 4 4 4 Direct current: DC13 Ue (V) 24 125 250 Ie (A) 3 0.55 0.3
with M12 connector, 8-pole	Thermal current ( $I_{th}$ ):	2 A
	Rated insulation voltage (U):	30 Vac 36 Vdc
	Protection against short circuits: Pollution degree:	type gG fuse 2 A 500 V 3
		Alternating current: AC15 (50±60 Hz) Ue (V) 24 Ie (A) 2 Direct current: DC13 Ue (V) 24 Ie (A) 2



### Features approved by IMQ

Rated insulation voltage (U<sub>i</sub>): 500 Vac  
 400 Vac (for contact blocks 2, 11, 12, 20, 21, 22, 28, 29, 30, 33, 34, 37)  
 Conventional free air thermal current (I<sub>th</sub>): 10 A  
 Protection against short circuits: type aM fuse 10 A 500 V  
 Rated impulse withstand voltage (U<sub>imp</sub>): 6 kV  
 4 kV (for contact blocks 20, 21, 22, 28, 29, 30, 33, 34)  
 Protection degree of the housing: IP67  
 MV terminals (screw terminals): 3  
 Pollution degree: AC15  
 Utilization category: 400 Vac (50 Hz)  
 Operating voltage (U<sub>e</sub>): 3 A  
 Operating current (I<sub>e</sub>):  
 Forms of the contact element: Za, Za+Za, X+X, Zb, Y+Y, Y+Y+X, Y+Y+Y, Y+X+X, Y, X.  
 Positive opening of contacts on contact blocks 5, 6, 7, 8, 9, 11, 13, 14, 16, 17, 18, 19, 20, 21, 22, 28, 29, 30, 33, 34, 37, 38, 39, 66.  
 In compliance with standards: EN 60947-1, EN 60947-5-1, fundamental requirements of the Low Voltage Directive 2014/35/EU.

Please contact our technical department for the list of approved products.

### Features approved by UL

Electrical Ratings: Q300 pilot duty (69 VA, 125-250 V dc)  
 A600 pilot duty (720 VA, 120-600 V ac)  
 Environmental Ratings: Types 1, 4X, 12, 13  
 For all contact blocks except 2 and 3 use 60 or 75°C copper (Cu) conductors, rigid or flexible, wire size 12, 14 AWG. Tightening torque for terminal screws of 7.1 lb in (0.8 Nm).  
 For contact blocks 2 and 3 use 60 or 75°C copper (Cu) conductors, rigid or flexible, wire size 14 AWG. Tightening torque for terminal screws of 12 lb in (1.4 Nm).

Please contact our technical department for the list of approved products.

### Wiring diagram for M12 connectors

Contact block 2 2x(1NO-1NC)	Contact block 5 1NO+1NC	Contact block 6 1NO+1NC	Contact block 7 1NO+1NC	Contact block 9 2NC	Contact block 10 2NO	Contact block 11 2NC	Contact block 12 2NO	Contact block 13 2NC
M12 connector, 8-pole	M12 connector, 5-pole	M12 connector, 5-pole	M12 connector, 5-pole	M12 connector, 5-pole	M12 connector, 5-pole	M12 connector, 5-pole	M12 connector, 5-pole	M12 connector, 5-pole
<b>Contacts Pin no.</b> NO 3-4 NC 5-6 NC 7-8 NO 1-2	<b>Contacts Pin no.</b> NC 1-2 NO 3-4 ground 5	<b>Contacts Pin no.</b> NC 1-2 NO 3-4 ground 5	<b>Contacts Pin no.</b> NC 1-2 NO 3-4 ground 5	<b>Contacts Pin no.</b> NC 1-2 NO 3-4 ground 5	<b>Contacts Pin no.</b> NO 1-2 NO 3-4 ground 5	<b>Contacts Pin no.</b> NC 1-2 NC 3-4 ground 5	<b>Contacts Pin no.</b> NO 1-2 NO 3-4 ground 5	<b>Contacts Pin no.</b> NC (1°) 1-2 NC (2°) 3-4 ground 5
Contact block 14 2NC	Contact block 15 2NO	Contact block 16 2NC	Contact block 18 1NO+1NC	Contact block 20 1NO+2NC	Contact block 21 3NC	Contact block 22 2NO+1NC	Contact block 33 1NO+1NC	Contact block 34 2NC
M12 connector, 5-pole	M12 connector, 5-pole	M12 connector, 5-pole	M12 connector, 5-pole	M12 connector, 8-pole	M12 connector, 8-pole	M12 connector, 8-pole	M12 connector, 5-pole	M12 connector, 5-pole
<b>Contacts Pin no.</b> NC (1°) 1-2 NC (2°) 3-4 ground 5	<b>Contacts Pin no.</b> NO (1°) 1-2 NO (2°) 3-4 ground 5	<b>Contacts Pin no.</b> NC, lever to the right 1-2 NC, lever to the left 3-4 ground 5	<b>Contacts Pin no.</b> NC 1-2 NO 3-4 ground 5	<b>Contacts Pin no.</b> NC 3-4 NO 5-6 NO 7-8 ground 1	<b>Contacts Pin no.</b> NC 3-4 NC 5-6 NC 7-8 ground 1	<b>Contacts Pin no.</b> NC 3-4 NO 5-6 NO 7-8 ground 1	<b>Contacts Pin no.</b> NC 1-2 NO 3-4 ground 5	<b>Contacts Pin no.</b> NC 1-2 NC 3-4 ground 5

Contact block E1  
PNP

M12 connector, 5-pole

<b>Contacts Pin no.</b>	
+	1
-	3
NC	2
NO	4
ground	5

# FL series position switches

Contact type		With steel roller with self-lubrication or 316L stainless steel on request		With steel roller with self-lubrication or 316L stainless steel on request		With steel roller with self-lubrication or 316L stainless steel on request	
<b>R</b>	= snap action						
<b>L</b>	= slow action						
<b>LO</b>	= slow action, make before break						
<b>LS</b>	= slow action, shifted						
<b>LV</b>	= slow action, shifted and spaced						
<b>LI</b>	= slow action, independent						
<b>LA</b>	= slow action, close						
	= electronic, PNP						
Contact block		With steel roller with self-lubrication or 316L stainless steel on request		With steel roller with self-lubrication or 316L stainless steel on request		With steel roller with self-lubrication or 316L stainless steel on request	
2	<b>R</b> FL 201-M2 2x(1NO-1NC)	FL 202-M2 2x(1NO-1NC)	FL 204-M2 2x(1NO-1NC)	FL 205-M2 2x(1NO-1NC)			
5	<b>R</b> FL 501-M2 1NO+1NC	FL 502-M2 1NO+1NC	FL 504-M2 1NO+1NC	FL 505-M2 1NO+1NC			
6	<b>L</b> FL 601-M2 1NO+1NC	FL 602-M2 1NO+1NC	FL 604-M2 1NO+1NC	FL 605-M2 1NO+1NC			
7	<b>LO</b> FL 701-M2 1NO+1NC	FL 702-M2 1NO+1NC	FL 704-M2 1NO+1NC	FL 705-M2 1NO+1NC			
9	<b>L</b> FL 901-M2 2NC	FL 902-M2 2NC	FL 904-M2 2NC	FL 905-M2 2NC			
10	<b>L</b> FL 1001-M2 2NO	FL 1002-M2 2NO	FL 1004-M2 2NO	FL 1005-M2 2NO			
11	<b>R</b> FL 1101-M2 2NC	FL 1102-M2 2NC	FL 1104-M2 2NC	FL 1105-M2 2NC			
12	<b>R</b> FL 1201-M2 2NO	FL 1202-M2 2NO	FL 1204-M2 2NO	FL 1205-M2 2NO			
13	<b>LV</b> FL 1301-M2 2NC	FL 1302-M2 2NC	FL 1304-M2 2NC	FL 1305-M2 2NC			
14	<b>LS</b> FL 1401-M2 2NC	FL 1402-M2 2NC	FL 1404-M2 2NC	FL 1405-M2 2NC			
15	<b>LS</b> FL 1501-M2 2NO	FL 1502-M2 2NO	FL 1504-M2 2NO	FL 1505-M2 2NO			
18	<b>LA</b> FL 1801-M2 1NO+1NC	FL 1802-M2 1NO+1NC	FL 1804-M2 1NO+1NC	FL 1805-M2 1NO+1NC			
20	<b>L</b> FL 2001-M2 1NO+2NC	FL 2002-M2 1NO+2NC	FL 2004-M2 1NO+2NC	FL 2005-M2 1NO+2NC			
21	<b>L</b> FL 2101-M2 3NC	FL 2102-M2 3NC	FL 2104-M2 3NC	FL 2105-M2 3NC			
22	<b>L</b> FL 2201-M2 2NO+1NC	FL 2202-M2 2NO+1NC	FL 2204-M2 2NO+1NC	FL 2205-M2 2NO+1NC			
E1	FL E101-M2 1NO-1NC	FL E102-M2 1NO-1NC	FL E104-M2 1NO-1NC	FL E105-M2 1NO-1NC			
Max. speed	page 229 - type 4	page 229 - type 3	0.5 m/s	page 229 - type 3			
Actuating force	8 N (25 N ⊕)	6 N (25 N ⊕)	0.17 Nm	6 N (25 N ⊕)			
Travel diagrams	page 230 - group 1	page 230 - group 2	page 230 - group 1	page 230 - group 2			

Contact type		Rope switch for signalling		External gasket			
<b>R</b>	= snap action						
<b>L</b>	= slow action						
<b>LO</b>	= slow action, make before break						
<b>LS</b>	= slow action, shifted						
<b>LV</b>	= slow action, shifted and spaced						
<b>LI</b>	= slow action, independent						
<b>LA</b>	= slow action, close						
	= electronic, PNP						
Contact block		Rope switch for signalling		External gasket			
2	<b>R</b> FL 208-M2 2x(1NO-1NC)	FL 209-M2 2x(1NO-1NC)	FL 210-M2 2x(1NO-1NC)	FL 211-M2 2x(1NO-1NC)			
5	<b>R</b> FL 508-M2 1NO+1NC	FL 509-M2 1NO+1NC	FL 510-M2 1NO+1NC	FL 511-M2 1NO+1NC			
6	<b>L</b> FL 608-M2 1NO+1NC	FL 609-M2 1NO+1NC	FL 610-M2 1NO+1NC	FL 611-M2 1NO+1NC			
7	<b>LO</b> FL 708-M2 1NO+1NC	FL 709-M2 1NO+1NC	FL 710-M2 1NO+1NC	FL 711-M2 1NO+1NC			
9	<b>L</b> FL 908-M2 2NC	FL 909-M2 2NC	FL 910-M2 2NC	FL 911-M2 2NC			
10	<b>L</b> FL 1008-M2 2NO	FL 1009-M2 2NO	FL 1010-M2 2NO	FL 1011-M2 2NO			
11	<b>R</b> FL 1108-M2 2NC	FL 1109-M2 2NC	FL 1110-M2 2NC	FL 1111-M2 2NC			
12	<b>R</b> FL 1208-M2 2NO	FL 1209-M2 2NO	FL 1210-M2 2NO	FL 1211-M2 2NO			
13	<b>LV</b> FL 1308-M2 2NC	FL 1309-M2 2NC	FL 1310-M2 2NC	FL 1311-M2 2NC			
14	<b>LS</b> FL 1408-M2 2NC	FL 1409-M2 2NC	FL 1410-M2 2NC	FL 1411-M2 2NC			
15	<b>LS</b> FL 1508-M2 2NO	FL 1509-M2 2NO	FL 1510-M2 2NO	FL 1511-M2 2NO			
18	<b>LA</b> FL 1808-M2 1NO+1NC	FL 1809-M2 1NO+1NC	FL 1810-M2 1NO+1NC	FL 1811-M2 1NO+1NC			
20	<b>L</b> FL 2008-M2 1NO+2NC	FL 2009-M2 1NO+2NC	FL 2010-M2 1NO+2NC	FL 2011-M2 1NO+2NC			
21	<b>L</b> FL 2108-M2 3NC	FL 2109-M2 3NC	FL 2110-M2 3NC	FL 2111-M2 3NC			
22	<b>L</b> FL 2208-M2 2NO+1NC	FL 2209-M2 2NO+1NC	FL 2210-M2 2NO+1NC	FL 2211-M2 2NO+1NC			
E1	FL E108-M2 1NO-1NC	FL E109-M2 1NO-1NC	FL E110-M2 1NO-1NC	FL E111-M2 1NO-1NC			
Max. speed	page 229 - type 4	0.5 m/s	page 229 - type 4	page 229 - type 4			
Actuating force	8 N (25 N ⊕)	7 N	11 N (25 N ⊕)	8 N (25 N ⊕)			
Travel diagrams	page 230 - group 1	/	page 230 - group 1	page 230 - group 1			

All values in the drawings are in mm

Accessories See page 207

→ The 2D and 3D files are available at [www.pizzato.com](http://www.pizzato.com)





Contact type	External gasket		Ball, Ø 8 mm, stainless steel		Ball, Ø 12.7 mm, stainless steel			
<b>R</b> = snap action								
<b>L</b> = slow action								
<b>LO</b> = slow action, make before break								
<b>LS</b> = slow action, shifted								
<b>LV</b> = slow action, shifted and spaced								
<b>LI</b> = slow action, independent								
<b>LA</b> = slow action, close								
<b>E1</b> = electronic, PNP								
Max. speed	page 229 - type 2		page 229 - type 2		page 229 - type 4		page 229 - type 4	
Actuating force	11 N (25 N		8 N (25 N		8 N (25 N		8 N (25 N	
Travel diagrams	page 230 - group 1		page 230 - group 1		page 230 - group 1		page 230 - group 1	

Contact type	External gasket		External gasket		External gasket		Other rollers available. See page 44	
<b>R</b> = snap action								
<b>L</b> = slow action								
<b>LO</b> = slow action, make before break								
<b>LS</b> = slow action, shifted								
<b>LV</b> = slow action, shifted and spaced								
<b>LI</b> = slow action, independent								
<b>LA</b> = slow action, close								
<b>E1</b> = electronic, PNP								
Max. speed	1 m/s		1 m/s		1 m/s		page 229 - type 1	
Actuating force	0.09 Nm		0.08 Nm		0.14 Nm		0.1 Nm (0.25 Nm	
Travel diagrams	page 230 - group 3		page 230 - group 3		page 230 - group 3		page 230 - group 4	

All values in the drawings are in mm

Accessories See page 207

The 2D and 3D files are available at [www.pizzato.com](http://www.pizzato.com)

# FL series position switches

		Round rod, Ø 3 mm, stainless steel		Square rod, 3x3 mm		Other rollers available. See page 44	
Contact type							
Contact block							
2	<b>R</b>	FL 232-M2	2x(1NO-1NC)	FL 233-M2	2x(1NO-1NC)	FL 234-M2	2x(1NO-1NC)
5	<b>R</b>	FL 532-M2	1NO+1NC	FL 533-M2	1NO+1NC	FL 534-M2	1NO+1NC
6	<b>L</b>	FL 632-M2	1NO+1NC	FL 633-M2	1NO+1NC	FL 634-M2	1NO+1NC
7	<b>LO</b>	FL 732-M2	1NO+1NC	FL 733-M2	1NO+1NC	FL 734-M2	1NO+1NC
9	<b>L</b>	FL 932-M2	2NC	FL 933-M2	2NC	FL 934-M2	2NC
10	<b>L</b>	FL 1032-M2	2NO	FL 1033-M2	2NO	FL 1034-M2	2NO
11	<b>R</b>	FL 1132-M2	2NC	FL 1133-M2	2NC	FL 1134-M2	2NC
12	<b>R</b>	FL 1232-M2	2NO	FL 1233-M2	2NO	FL 1234-M2	2NO
13	<b>LV</b>	FL 1332-M2	2NC	FL 1333-M2	2NC	FL 1334-M2	2NC
14	<b>LS</b>	FL 1432-M2	2NC	FL 1433-M2	2NC	FL 1434-M2	2NC
15	<b>LS</b>	FL 1532-M2	2NO	FL 1533-M2	2NO	FL 1534-M2	2NO
16	<b>LI</b>	FL 1632-M2	2NC	FL 1633-M2	2NC	FL 1634-M2	2NC
18	<b>LA</b>	FL 1832-M2	1NO+1NC	FL 1833-M2	1NO+1NC	FL 1834-M2	1NO+1NC
20	<b>L</b>	FL 2032-M2	1NO+2NC	FL 2033-M2	1NO+2NC	FL 2034-M2	1NO+2NC
21	<b>L</b>	FL 2132-M2	3NC	FL 2133-M2	3NC	FL 2134-M2	3NC
22	<b>L</b>	FL 2232-M2	2NO+1NC	FL 2233-M2	2NO+1NC	FL 2234-M2	2NO+1NC
E1		FL E132-M2	1NO-1NC	FL E133-M2	1NO-1NC	FL E134-M2	1NO-1NC
Max. speed		1.5 m/s		1.5 m/s		1 m/s	
Actuating force		0.1 Nm		0.1 Nm		0.1 Nm	
Travel diagrams		page 230 - group 4		page 230 - group 4		page 230 - group 4	
							page 229 - type 1
							0.1 Nm (0.25 Nm ⊖)
							page 230 - group 4

		Glass fibre rod		Other rollers available. See page 44		Other rollers available. See page 44		Porcelain roller	
Contact type									
Contact block									
2	<b>R</b>	FL 236-M2	2x(1NO-1NC)	FL 251-M2	2x(1NO-1NC)	FL 252-M2	2x(1NO-1NC)	FL 253-E11M2	2x(1NO-1NC)
5	<b>R</b>	FL 536-M2	1NO+1NC	FL 551-M2	1NO+1NC	FL 552-M2	1NO+1NC	FL 553-E11M2V9	1NO+1NC
6	<b>L</b>	FL 636-M2	1NO+1NC	FL 651-M2	1NO+1NC	FL 652-M2	1NO+1NC	FL 653-E11M2V9	1NO+1NC
7	<b>LO</b>	FL 736-M2	1NO+1NC	FL 751-M2	1NO+1NC	FL 752-M2	1NO+1NC	FL 753-E11M2V9	1NO+1NC
9	<b>L</b>	FL 936-M2	2NC	FL 951-M2	2NC	FL 952-M2	2NC	FL 953-E11M2V9	2NC
10	<b>L</b>	FL 1036-M2	2NO	FL 1051-M2	2NO	FL 1052-M2	2NO	FL 1053-E11M2V9	2NO
11	<b>R</b>	FL 1136-M2	2NC	FL 1151-M2	2NC	FL 1152-M2	2NC	/	
12	<b>R</b>	FL 1236-M2	2NO	FL 1251-M2	2NO	FL 1252-M2	2NO	FL 1253-E11M2V9	2NO
13	<b>LV</b>	FL 1336-M2	2NC	FL 1351-M2	2NC	FL 1352-M2	2NC	FL 1353-E11M2V9	2NC
14	<b>LS</b>	FL 1436-M2	2NC	FL 1451-M2	2NC	FL 1452-M2	2NC	FL 1453-E11M2V9	2NC
15	<b>LS</b>	FL 1536-M2	2NO	FL 1551-M2	2NO	FL 1552-M2	2NO	FL 1553-E11M2V9	2NO
16	<b>LI</b>	FL 1636-M2	2NC	/		/		/	
18	<b>LA</b>	FL 1836-M2	1NO+1NC	FL 1851-M2	1NO+1NC	FL 1852-M2	1NO+1NC	FL 1853-E11M2V9	1NO+1NC
20	<b>L</b>	FL 2036-M2	1NO+2NC	FL 2051-M2	1NO+2NC	FL 2052-M2	1NO+2NC	FL 2053-E11M2V9	1NO+2NC
21	<b>L</b>	FL 2136-M2	3NC	FL 2151-M2	3NC	FL 2152-M2	3NC	FL 2153-E11M2V9	3NC
22	<b>L</b>	FL 2236-M2	2NO+1NC	FL 2251-M2	2NO+1NC	FL 2252-M2	2NO+1NC	FL 2253-E11M2V9	2NO+1NC
E1		FL E136-M2	1NO-1NC	FL E151-M2	1NO-1NC	FL E152-M2	1NO-1NC	FL E153-E11M2V9	1NO-1NC
Max. speed		1.5 m/s		page 229 - type 1		page 229 - type 1		0.5 m/s	
Actuating force		0.1 Nm		0.06 Nm (0.25 Nm ⊖)		0.06 Nm (0.25 Nm ⊖)		0.03 Nm (0.25 Nm ⊖)	
Travel diagrams		page 230 - group 4		page 230 - group 4		page 230 - group 4		page 230 - group 5	

(1) Positive opening only with actuator set to max. See page 44.

All values in the drawings are in mm

Accessories See page 207

→ The 2D and 3D files are available at [www.pizzato.com](http://www.pizzato.com)



Contact type	Other rollers available. See page 44		Other rollers available. See page 44		With steel roller with self-lubrication or 316L stainless steel on request	With steel roller with self-lubrication or 316L stainless steel on request	
<ul style="list-style-type: none"> <li><b>R</b> = snap action</li> <li><b>L</b> = slow action</li> <li><b>LO</b> = slow action, make before break</li> <li><b>LS</b> = slow action, shifted</li> <li><b>LV</b> = slow action, shifted and spaced</li> <li><b>LI</b> = slow action, independent</li> <li><b>LA</b> = slow action, close</li> <li><b>E</b> = electronic, PNP</li> </ul>							
Contact block							
2	<b>R</b>	FL 256-M2	2x(1NO-1NC)	FL 257-M2	2x(1NO-1NC)	/	
5	<b>R</b>	FL 556-M2	1NO+1NC	FL 557-M2	1NO+1NC	FL 541-M2 1NO+1NC	
6	<b>L</b>	FL 656-M2	1NO+1NC	FL 657-M2	1NO+1NC	Bistable switch with lyra lever, single track  Bistable switch with lyra lever, dual track  0 45° 65° 80° 90° 25° S S = mechanical switching point positive opening on contacts 21-22 only	
7	<b>LO</b>	FL 756-M2	1NO+1NC	FL 757-M2	1NO+1NC		
9	<b>L</b>	FL 956-M2	2NC	FL 957-M2	2NC		
10	<b>L</b>	FL 1056-M2	2NO	FL 1057-M2	2NO		
11	<b>R</b>	FL 1156-M2	2NC	FL 1157-M2	2NC		
12	<b>R</b>	FL 1256-M2	2NO	FL 1257-M2	2NO		
13	<b>LV</b>	FL 1356-M2	2NC	FL 1357-M2	2NC		
14	<b>LS</b>	FL 1456-M2	2NC	FL 1457-M2	2NC		
15	<b>LS</b>	FL 1556-M2	2NO	FL 1557-M2	2NO		
16	<b>LI</b>	FL 1656-M2	2NC	FL 1657-M2	2NC		
18	<b>LA</b>	FL 1856-M2	1NO+1NC	FL 1857-M2	1NO+1NC		
20	<b>L</b>	FL 2056-M2	1NO+2NC	FL 2057-M2	1NO+2NC		
21	<b>L</b>	FL 2156-M2	3NC	FL 2157-M2	3NC		
22	<b>L</b>	FL 2256-M2	2NO+1NC	FL 2257-M2	2NO+1NC		
E1	<b>E</b>	FL E156-M2	1NO-1NC	FL E157-M2	1NO-1NC		
Max. speed	page 229 - type 1		page 229 - type 1		0.5 m/s with cam at 30°		0.5 m/s with cam at 30°
Actuating force	0.1 Nm (0.25 Nm)		0.1 Nm (0.25 Nm)		0.21 Nm (0.36 Nm)		0.21 Nm (0.36 Nm)
Travel diagrams	page 230 - group 4		page 230 - group 4		/		/

Contact type	Rope switch for signalling		
<ul style="list-style-type: none"> <li><b>R</b> = snap action</li> <li><b>L</b> = slow action</li> <li><b>LO</b> = slow action, make before break</li> <li><b>LS</b> = slow action, shifted</li> <li><b>LV</b> = slow action, shifted and spaced</li> <li><b>LI</b> = slow action, independent</li> <li><b>LA</b> = slow action, close</li> <li><b>E</b> = electronic, PNP</li> </ul>			
Contact block			
2	<b>R</b>	FL 276-M2	2x(1NO-1NC)
5	<b>R</b>	FL 576-M2	1NO+1NC
6	<b>L</b>	FL 676-M2	1NO+1NC
7	<b>LO</b>	FL 776-M2	1NO+1NC
9	<b>L</b>	FL 976-M2	2NO
10	<b>L</b>	FL 1076-M2	2NC
11	<b>R</b>	FL 1176-M2	2NO
12	<b>R</b>	FL 1276-M2	2NC
13	<b>LV</b>	FL 1376-M2	2NO
14	<b>LS</b>	FL 1476-M2	2NO
15	<b>LS</b>	FL 1576-M2	2NC
16	<b>LI</b>	/	
18	<b>LA</b>	FL 1876-M2	1NO+1NC
20	<b>L</b>	FL 2076-M2	2NO+1NC
21	<b>L</b>	FL 2176-M2	3NO
22	<b>L</b>	FL 2276-M2	1NO+2NC
E1	<b>E</b>	/	
Max. speed	0.5 m/s		
Actuating force	initial 20 N - final 40 N		
Travel diagrams	page 230 - group 6		

All values in the drawings are in mm

Accessories See page 207

The 2D and 3D files are available at [www.pizzato.com](http://www.pizzato.com)

## Position switches with swivelling lever without actuator

Contact type		Regular head	Compact head	
<b>R</b>	= snap action			
<b>L</b>	= slow action			
<b>LO</b>	= slow action, make before break			
<b>LS</b>	= slow action, shifted			
<b>LV</b>	= slow action, shifted and spaced			
<b>LI</b>	= slow action, independent			
<b>LA</b>	= slow action, close			
<b>Λ</b>	= electronic, PNP			
Contact block				
2	<b>R</b> FL 238-M2	2x(1NO-1NC)	FL 258-M2	2x(1NO-1NC)
5	<b>R</b> FL 538-M2	1NO+1NC	FL 558-M2	1NO+1NC
6	<b>L</b> FL 638-M2	1NO+1NC	FL 658-M2	1NO+1NC
7	<b>LO</b> FL 738-M2	1NO+1NC	FL 758-M2	1NO+1NC
9	<b>L</b> FL 938-M2	2NC	FL 958-M2	2NC
10	<b>L</b> FL 1038-M2	2NO	FL 1058-M2	2NO
11	<b>R</b> FL 1138-M2	2NC	FL 1158-M2	2NC
12	<b>R</b> FL 1238-M2	2NO	FL 1258-M2	2NO
13	<b>LV</b> FL 1338-M2	2NC	FL 1358-M2	2NC
14	<b>LS</b> FL 1438-M2	2NC	FL 1458-M2	2NC
15	<b>LS</b> FL 1538-M2	2NO	FL 1558-M2	2NO
16	<b>LI</b> FL 1638-M2	2NC	/	
18	<b>LA</b> FL 1838-M2	1NO+1NC	FL 1858-M2	1NO+1NC
20	<b>L</b> FL 2038-M2	1NO+2NC	FL 2058-M2	1NO+2NC
21	<b>L</b> FL 2138-M2	3NC	FL 2158-M2	3NC
22	<b>L</b> FL 2238-M2	2NO+1NC	FL 2258-M2	2NO+1NC
E1	<b>Λ</b> FL E138-M2	1NO-1NC	FL E158-M2	1NO-1NC
Actuating force		0.1 Nm (0.25 Nm $\rightarrow$ )	0.06 Nm (0.25 Nm $\rightarrow$ )	0.21 Nm (0.36 Nm $\rightarrow$ )
Travel diagrams		page 230 - group 4	page 230 - group 4	/

### IMPORTANT

**For safety applications:** join only switches and actuators marked with symbol  $\rightarrow$  next to the product code.

For more information about safety applications see details on page 225.

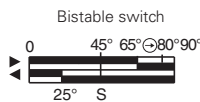

S = mechanical switching point positive opening on contacts 21-22 only

## Separate actuators

**IMPORTANT:** These separate actuators can be used only with items of the FD, FP, FL and FC series.

Technopolymer roller Ø 20 mm	Adjustable round rod Ø 3x125 mm	Adjustable square rod, 3x3x125 mm	Spring rod with plastic tip	Adjustable actuator with technopolymer roller	Adjustable glass fibre rod	
 <b>VF L31</b> $\rightarrow$	 <b>VF L32</b> $\rightarrow$ (3)	 <b>VF L33</b> $\rightarrow$ (3)	 <b>VF L34</b>	 <b>VF L35</b> $\rightarrow$ (1) (3)	 <b>VF L36</b> $\rightarrow$ (3)	
Lyra actuator, single track	Lyra actuator, dual track	Technopolymer roller, Ø 20 mm	Technopolymer roller, Ø 20 mm	Porcelain roller	Adjustable safety actuator with technopolymer roller	Technopolymer roller, Ø 20 mm
 <b>VF L41</b> $\rightarrow$	 <b>VF L42</b> $\rightarrow$	 <b>VF L51</b> $\rightarrow$	 <b>VF L52</b> $\rightarrow$	 <b>VF L53</b> $\rightarrow$ (2)	 <b>VF L56</b> $\rightarrow$ (3)	 <b>VF L57</b> $\rightarrow$

All values in the drawings are in mm

Accessories See page 207

$\rightarrow$  The 2D and 3D files are available at [www.pizzato.com](http://www.pizzato.com)

## Special separate actuators

**IMPORTANT:** These separate actuators can be used only with items of the FD, FP, FL and FC series.

Steel rollers, Ø 20 mm, with self-lubrication

VF L31-R24 (1)	VF L35-R24 (1) (3)	VF L51-R24 (1)	VF L52-R24 (1)	VF L56-R24 (3)	VF L57-R24 (1)

**Note:** To order with 316L stainless steel roller: replace R24 with R41 in the order numbers.

Technopolymer rollers, Ø 35 mm

VF L31-R25 (4)	VF L35-R25 (1) (3)	VF L51-R25 (4)	VF L52-R25 (1)	VF L56-R25 (3)	VF L57-R25 (1)

Rubber rollers, Ø 40 mm

VF L31-R5 (4)	VF L35-R5 (1) (3)	VF L51-R5 (4)	VF L52-R5 (1)	VF L56-R5 (3)	VF L57-R5 (4)

Rubber rollers, Ø 50 mm

VF L31-R26 (4)	VF L35-R26 (1) (3)	VF L51-R26 (4)	VF L52-R26 (4)	VF L56-R26 (3)	VF L57-R26 (4)

Protruding rubber rollers, Ø 50 mm

VF L35-R27 (1) (3)	VF L56-R27 (3)

- (1) Lever VF L35 can only be used in safety applications if adjusted to its max. length, as shown in the figure to the right. If an adjustable lever is required for safety applications, use the VF L56 adjustable safety lever.
- (2) The position switch obtained by assembling switch FL •58-M2 (e.g. FL 558-M2, FL 658-M2, ...) with actuator VF L53 will not present the same travel diagrams and actuating forces as switch FL •53-E11M2V9 (e.g. FL 553-E11M2V9, FL 653-E11M2V9, ...)
- (3) If installed with switch FL •58-M2 (e.g. FL 558-M2, FL 658-M2, ...) the actuator may hit the housing of the switch upon actuation. This possible interference depends on the fixing position of actuator and switch head.
- (4) The actuator cannot be rotated to the inside because it will hit the switch head upon actuation.

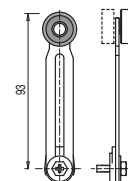

All values in the drawings are in mm

Accessories See page 207

→ The 2D and 3D files are available at [www.pizzato.com](http://www.pizzato.com)

## Selection diagram

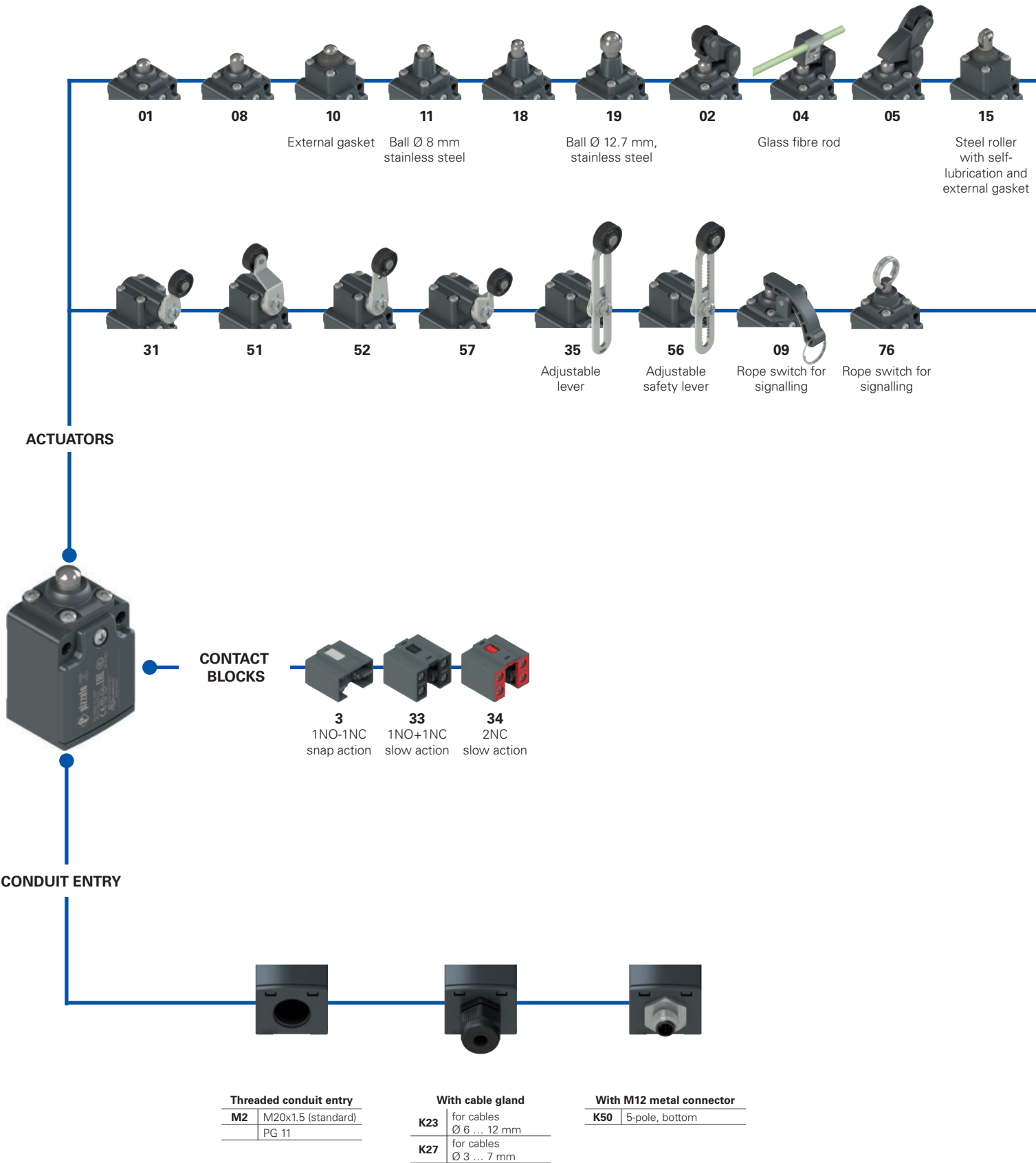

● Product options  
→ Sold separately as accessory

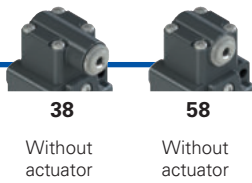
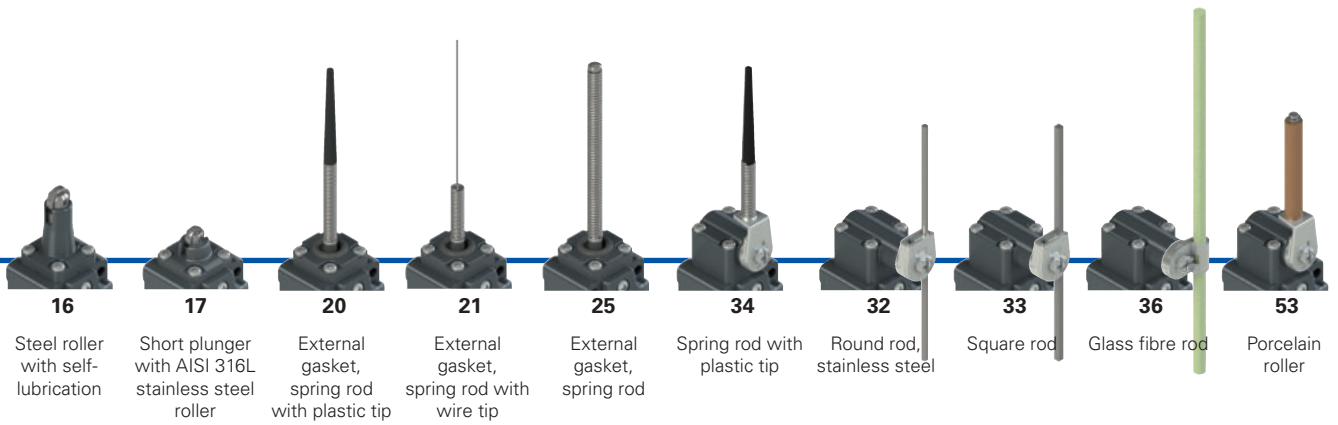

**SEPARATE ACTUATORS**  
See page 51

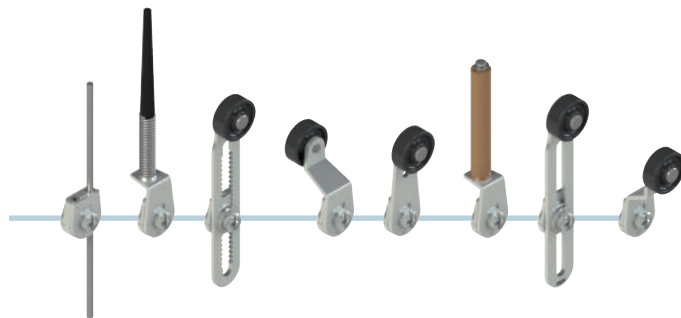

### Code structure

**Attention!** The feasibility of a code number does not mean the effective availability of a product. Please contact our sales office.

article options options  
**FC 302-GM2K50R24T6**

<b>Housing</b>		<b>Ambient temperature</b>	
<b>FC</b>	metal, one conduit entry		-25°C ... +80°C (standard)
<b>Contact block</b>		<b>T6</b>	-40°C ... +80°C
<b>3</b>	1NO+1NC, snap action	<b>Rollers</b>	
<b>33</b>	1NO+1NC, slow action		standard roller
<b>34</b>	2NC, slow action	<b>R24</b>	Steel, with self-lubrication, Ø 20 mm (for actuators 02, 05, 31, 35, 51, 52, 56, 57)
<b>Actuators</b>		<b>R41</b>	316L stainless steel, Ø 20 mm (for actuators 02, 05, 31, 35, 51, 52, 56, 57)
<b>01</b>	short plunger	<b>R25</b>	technopolymer, Ø 35 mm (for actuators 31, 35, 51, 52, 56, 57)
<b>02</b>	roller lever	<b>R5</b>	rubber, Ø 40 mm (for actuators 31, 35, 51, 52, 56, 57)
<b>05</b>	angled lever with roller	<b>R26</b>	rubber, Ø 50 mm (for actuators 31, 35, 51, 52, 56, 57)
...	...	<b>R27</b>	rubber, protruding, Ø 50 mm (for actuators 35 and 56)
<b>Contact type</b>		<b>Pre-installed cable glands</b>	
	silver contacts (standard)		no cable gland (standard)
<b>G</b>	silver contacts, 1 µm gold coating	<b>K23</b>	cable gland for cables Ø 6 ... 12 mm
<b>Threaded conduit entry</b>		<b>K27</b>	cable gland for cables Ø 3 ... 7°mm
<b>M2</b>	M20x1.5 (standard)	<b>K50</b>	M12 metal connector, 5-pole
	PG11	For the complete list of possible combinations please contact our technical department.	

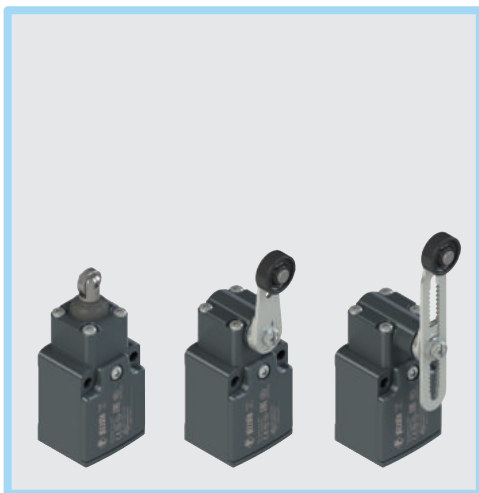

### Main features

- Metal housing, one conduit entry
- Protection degree IP67
- 3 contact blocks available
- 27 actuators available
- Versions with M12 connector
- Versions with gold-plated silver contacts

### Technical data

#### Housing

Metal housing, powder-coated  
 One threaded conduit entry: M20x1.5 (standard)  
 Protection degree acc. to EN 60529: IP67 with cable gland of equal or higher protection degree

#### General data

Ambient temperature: -25°C ... +80°C (standard)  
 -40°C ... +80°C (T6 option)  
 Max. actuation frequency: 3600 operating cycles/hour  
 Mechanical endurance: 20 million operating cycles  
 Mounting position: any  
 Safety parameter  $B_{10D}$ : 40,000,000 for NC contacts  
 Mechanical interlock, not coded: type 1 acc. to EN ISO 14119  
 Tightening torques for installation: see page 229  
 Wire cross-sections and wire stripping lengths: see page 249

#### In compliance with standards:

IEC 60947-5-1, EN 60947-5-1, EN 60947-1, IEC 60204-1, EN 60204-1, EN ISO 14119, EN ISO 12100, IEC 60529, EN 60529, EN IEC 63000, UL 508, CSA C22.2 No. 14.

#### Approvals:

IEC 60947-5-1, UL 508, CSA C22.2 No. 14, GB/T14048.5.

#### Compliance with the requirements of:

Low Voltage Directive 2014/35/EU, EMC Directive 2014/30/EU, RoHS Directive 2011/65/EU.

#### Positive contact opening in conformity with standards:

IEC 60947-5-1, EN 60947-5-1.

### Quality marks:



IMQ approval: EG605  
 UL approval: E131787  
 CCC approval: 2021000305000099  
 EAC approval: RU C-IT.YT03.B.00035/19

### Installation for safety applications:

Use only switches marked with the  $\ominus$  symbol beside the product code. Always connect the safety circuit to the **NC contacts** (normally closed contacts: 11-12, 21-22 or 31-32) as required by **EN ISO 14119, paragraph 5.4** for specific interlock applications and **EN ISO 13849-2 tables D3** (well-tried components) and **D.8** (fault exclusions) for safety applications in general. Actuate the switch **at least up to the positive opening travel** shown in the travel diagrams on page 230. Actuate the switch **at least with the positive opening force**, reported in brackets below each article, next to the actuating force value.

**⚠ If not expressly indicated in this chapter, for correct installation and utilization of all articles see the instructions given on pages 227 to 242.**

	Electrical data	Utilization category
without connector	Thermal current ( $I_{th}$ ):	10 A
	Rated insulation voltage ( $U_i$ ):	500 Vac 600 Vdc 400 Vac 500 Vdc (contact blocks 33, 34)
	Rated impulse withstand voltage ( $U_{imp}$ ):	6 kV 4 kV (contact block 33, 34)
	Conditional short circuit current: Protection against short circuits: Pollution degree:	1000 A acc. to EN 60947-5-1 type aM fuse 10 A 500 V 3
with M12 connector, 5-pole	Thermal current ( $I_{th}$ ):	4 A
	Rated insulation voltage ( $U_i$ ):	250 Vac 300 Vdc
	Protection against short circuits: Pollution degree:	type gG fuse 4 A 500 V 3
		Alternating current: AC15 (50+60 Hz)
		Ue (V) 250 400 500
		Ie (A) 6 4 1
		Direct current: DC13
		Ue (V) 24 125 250
		Ie (A) 3 0.55 0.3
		Alternating current: AC15 (50+60 Hz)
		Ue (V) 24 120 250
		Ie (A) 4 4 4
		Direct current: DC13
		Ue (V) 24 125 250
		Ie (A) 3 0.55 0.3



### Features approved by IMQ

Rated insulation voltage ( $U_i$ ): 500 Vac  
 400 Vac (for contact blocks 33, 34)  
 Conventional free air thermal current ( $I_{th}$ ): 10 A  
 Protection against short circuits: type aM fuse 10 A 500 V  
 Rated impulse withstand voltage ( $U_{imp}$ ): 6 kV  
 4 kV (for contact blocks 33, 34)  
 Protection degree of the housing: IP67  
 MV terminals (screw terminals)  
 Pollution degree: 3  
 Utilization category: AC15  
 Operating voltage ( $U_e$ ): 400 Vac (50 Hz)  
 Operating current ( $I_e$ ): 3 A  
 Forms of the contact element: Za, Zb, Y+Y  
 Positive opening of contacts on contact blocks 33, 34.  
 In compliance with standards: EN 60947-1, EN 60947-5-1, fundamental requirements of the Low Voltage Directive 2014/35/EU.

**Please contact our technical department for the list of approved products.**

### Features approved by UL

Electrical Ratings: Q300 pilot duty (69 VA, 125-250 Vdc)  
 A600 pilot duty (720 VA, 120 ... 600V ac)  
 Environmental Ratings: Types 1, 4X, 12, 13  
 For all contact blocks except 2 and 3 use 60 or 75°C copper (Cu) conductors, rigid or flexible, wire size 12, 14 AWG. Tightening torque for terminal screws of 7.1 lb in (0.8 Nm).  
 For contact blocks 2 and 3 use 60 or 75°C copper (Cu) conductors, rigid or flexible, wire size 14 AWG. Tightening torque for terminal screws of 12 lb in (1.4 Nm).

**Please contact our technical department for the list of approved products.**

### Wiring diagram for M12 connectors

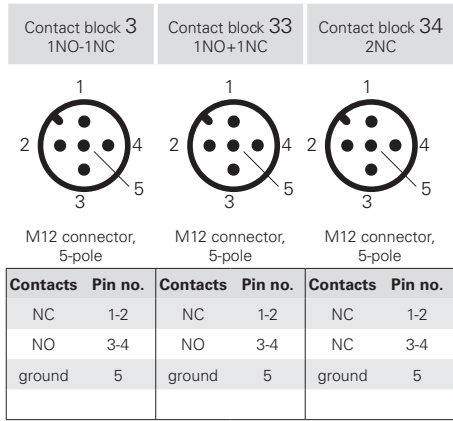

Contact type  
**R** = snap action  
**L** = slow action

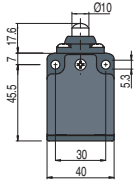
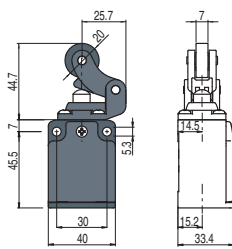
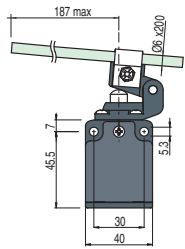
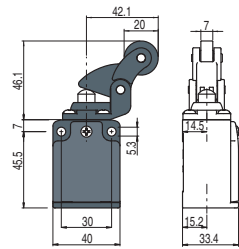
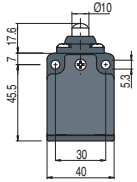
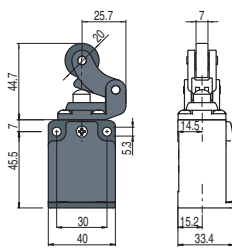
				With steel roller with self-lubrication or 316L stainless steel on request		With steel roller with self-lubrication or 316L stainless steel on request	
Contact block							
3	<b>R</b>	<b>FC 301-M2</b>	1NO-1NC	<b>FC 302-M2</b>	1NO-1NC	<b>FC 304-M2</b>	1NO-1NC
33	<b>L</b>	<b>FC 3301-M2</b>	1NO+1NC	<b>FC 3302-M2</b>	1NO+1NC	<b>FC 3304-M2</b>	1NO+1NC
34	<b>L</b>	<b>FC 3401-M2</b>	2NC	<b>FC 3402-M2</b>	2NC	<b>FC 3404-M2</b>	2NC
Max. speed		page 229 - type 4		page 229 - type 3		0.5 m/s	
Actuating force		6 N (25 N)		4 N (25 N)		0.17 Nm	
Travel diagrams		page 230 - group 1		page 230 - group 2		page 230 - group 1	

Contact type  
**R** = snap action  
**L** = slow action

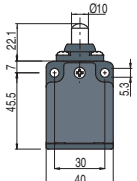
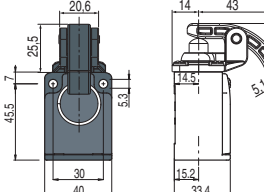
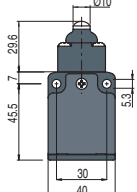
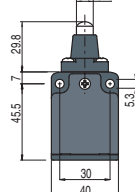
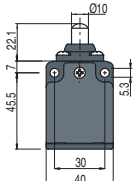
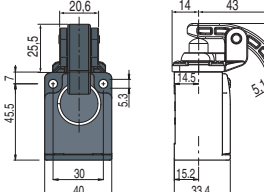
		Rope switch for signalling		External gasket			
Contact block							
3	<b>R</b>	<b>FC 308-M2</b>	1NO-1NC	<b>FC 309-M2</b>	1NO-1NC	<b>FC 310-M2</b>	1NO-1NC
33	<b>L</b>	<b>FC 3308-M2</b>	1NO+1NC	<b>FC 3309-M2</b>	1NO+1NC	<b>FC 3310-M2</b>	1NO+1NC
34	<b>L</b>	<b>FC 3408-M2</b>	2NC	<b>FC 3409-M2</b>	2NC	<b>FC 3410-M2</b>	2NC
Max. speed		page 229 - type 4		0.5 m/s		page 229 - type 4	
Actuating force		6 N (25 N)		7 N		7 N (25 N)	
Travel diagrams		page 230 - group 1		/		page 230 - group 1	

Contact type  
**R** = snap action  
**L** = slow action

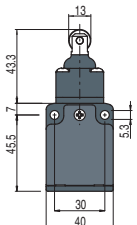
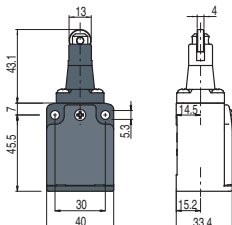
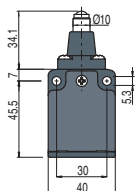
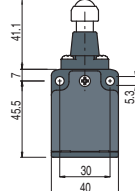
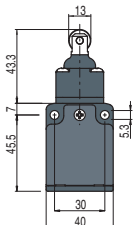
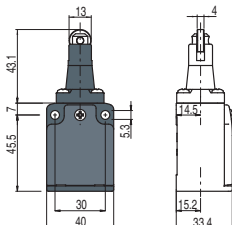
		External gasket		Ball, Ø 8 mm, stainless steel		Ball, Ø 12.7 mm, stainless steel	
Contact block							
3	<b>R</b>	<b>FC 315-M2</b>	1NO-1NC	<b>FC 316-M2</b>	1NO-1NC	<b>FC 318-M2</b>	1NO-1NC
33	<b>L</b>	<b>FC 3315-M2</b>	1NO+1NC	<b>FC 3316-M2</b>	1NO+1NC	<b>FC 3318-M2</b>	1NO+1NC
34	<b>L</b>	<b>FC 3415-M2</b>	2NC	<b>FC 3416-M2</b>	2NC	<b>FC 3418-M2</b>	2NC
Max. speed		page 229 - type 2		page 229 - type 2		page 229 - type 4	
Actuating force		7 N (25 N)		6 N (25 N)		6 N (25 N)	
Travel diagrams		page 230 - group 1		page 230 - group 1		page 230 - group 1	

All values in the drawings are in mm

Accessories See page 207

→ The 2D and 3D files are available at [www.pizzato.com](http://www.pizzato.com)

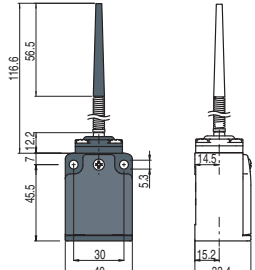
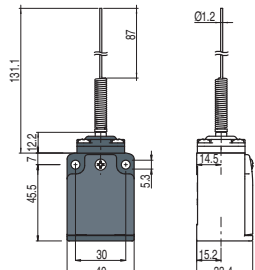
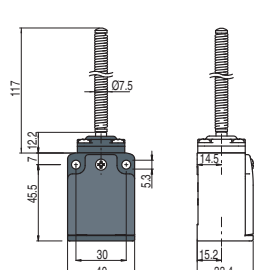
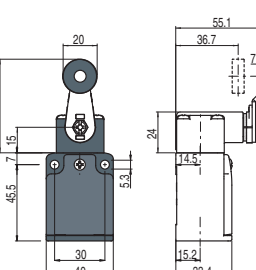

Contact type		External gasket		External gasket		External gasket		Other rollers available. See page 52	
<b>R</b> = snap action <b>L</b> = slow action									
Contact block									
3	<b>R</b>	FC 320-M2	1NO-1NC	FC 321-M2	1NO-1NC	FC 325-M2	1NO-1NC	FC 331-M2	1NO-1NC
33	<b>L</b>	FC 3320-M2	1NO+1NC	FC 3321-M2	1NO+1NC	FC 3325-M2	1NO+1NC	FC 3331-M2	1NO+1NC (⊕)
34	<b>L</b>	FC 3420-M2	2NC	FC 3421-M2	2NC	FC 3425-M2	2NC	FC 3431-M2	2NC (⊕)
Max. speed		1 m/s		1 m/s		1 m/s		page 229 - type 1	
Actuating force		0.07 Nm		0.06 Nm		0.1 Nm		0.09 Nm (0.25 Nm ⊕)	
Travel diagrams		page 230 - group 3		page 230 - group 3		page 230 - group 3		page 230 - group 4	

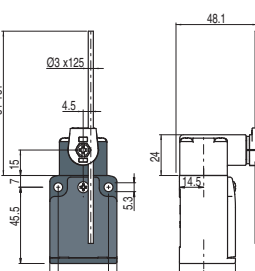
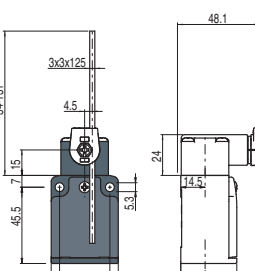
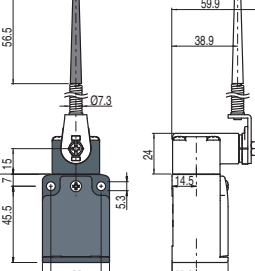
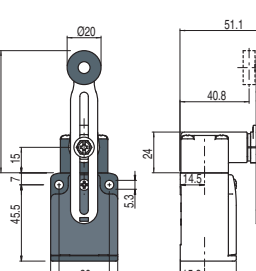
Contact type		Round rod, Ø 3 mm, stainless steel		Square rod, 3x3 mm		Other rollers available. See page 52			
<b>R</b> = snap action <b>L</b> = slow action									
Contact block									
3	<b>R</b>	FC 332-M2	1NO-1NC	FC 333-M2	1NO-1NC	FC 334-M2	1NO-1NC	FC 335-M2	1NO-1NC
33	<b>L</b>	FC 3332-M2	1NO+1NC	FC 3333-M2	1NO+1NC	FC 3334-M2	1NO+1NC	FC 3335-M2	1NO+1NC (⊕) <sup>(1)</sup>
34	<b>L</b>	FC 3432-M2	2NC	FC 3433-M2	2NC	FC 3434-M2	2NC	FC 3435-M2	2NC (⊕) <sup>(1)</sup>
Max. speed		1.5 m/s		1.5 m/s		1 m/s		page 229 - type 1	
Actuating force		0.09 Nm		0.09 Nm		0.09 Nm		0.09 Nm (0.25 Nm ⊕)	
Travel diagrams		page 230 - group 4		page 230 - group 4		page 230 - group 4		page 230 - group 4	

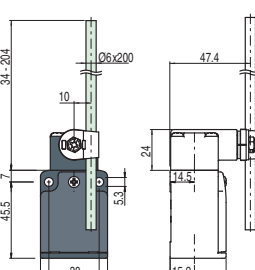
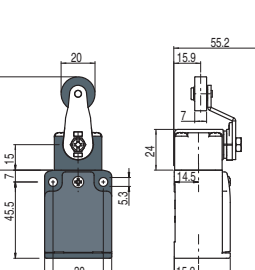
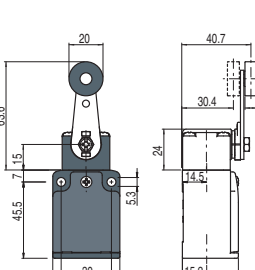
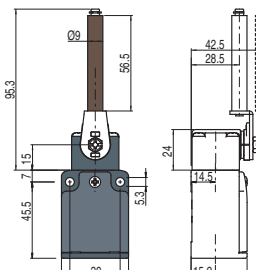
Contact type		Glass fibre rod		Other rollers available. See page 52		Other rollers available. See page 52		Porcelain roller	
<b>R</b> = snap action <b>L</b> = slow action									
Contact block									
3	<b>R</b>	FC 336-M2	1NO-1NC	FC 351-M2	1NO-1NC	FC 352-M2	1NO-1NC	FC 353-E11M2	1NO-1NC
33	<b>L</b>	FC 3336-M2	1NO+1NC	FC 3351-M2	1NO+1NC (⊕)	FC 3352-M2	1NO+1NC (⊕)	FC 3353-E11M2V9	1NO+1NC (⊕)
34	<b>L</b>	FC 3436-M2	2NC	FC 3451-M2	2NC (⊕)	FC 3452-M2	2NC (⊕)	FC 3453-E11M2V9	2NC (⊕)
Max. speed		1.5 m/s		page 229 - type 1		page 229 - type 1		0.5 m/s	
Actuating force		0.09 Nm		0.05 Nm (0.25 Nm ⊕)		0.05 Nm (0.25 Nm ⊕)		0.02 Nm (0.25 Nm ⊕)	
Travel diagrams		page 230 - group 4		page 230 - group 4		page 230 - group 4		page 230 - group 5	

<sup>(1)</sup> Positive opening only with actuator set to max. See page 52.

All values in the drawings are in mm

Accessories See page 207

➔ The 2D and 3D files are available at [www.pizzato.com](http://www.pizzato.com)

Contact type  
**R** = snap action  
**L** = slow action

	Other rollers available. See page 52	Other rollers available. See page 52	Rope switch for signalling
Contact block			
3 <b>R</b>	FC 356-M2 1NO-1NC	FC 357-M2 1NO-1NC	FC 376-M2 1NO-1NC
33 <b>L</b>	FC 3356-M2 ⊕ 1NO+1NC	FC 3357-M2 ⊕ 1NO+1NC	FC 3376-M2 1NO+1NC
34 <b>L</b>	FC 3456-M2 ⊕ 2NC	FC 3457-M2 ⊕ 2NC	FC 3476-M2 2NO
Max. speed	page 229 - type 1	page 229 - type 1	0.5 m/s
Actuating force	0.09 Nm (0.25 Nm ⊕)	0.09 Nm (0.25 Nm ⊕)	initial 20 N - final 40 N
Travel diagrams	page 230 - group 4	page 230 - group 4	page 230 - group 6

**Position switches with swivelling lever without actuator**

Contact type  
**R** = snap action  
**L** = slow action

	Regular head	Compact head
Contact block		
3 <b>R</b>	FC 338-M2 1NO-1NC	FC 358-M2 1NO-1NC
33 <b>L</b>	FC 3338-M2 ⊕ 1NO+1NC	FC 3358-M2 ⊕ 1NO+1NC
34 <b>L</b>	FC 3438-M2 ⊕ 2NC	FC 3458-M2 ⊕ 2NC
Actuating force	0.09 Nm (0.25 Nm ⊕)	0.05 Nm (0.25 Nm ⊕)
Travel diagrams	page 230 - group 4	page 230 - group 4

**IMPORTANT**

**For safety applications:** join only switches and actuators marked with symbol ⊕ next to the product code. For more information about safety applications see details on page 225.

**Separate actuators**

**IMPORTANT:** These separate actuators can be used only with items of the FD, FP, FL and FC series.

Technopolymer roller Ø 20 mm	Adjustable round rod Ø 3x125 mm	Adjustable square rod, 3x3x125 mm	Spring rod with plastic tip	Adjustable actuator with technopolymer roller	Adjustable glass fibre rod
VF L31 ⊕	VF L32 (3)	VF L33 (3)	VF L34	VF L35 ⊕ (1) (3)	VF L36 (3)
Technopolymer roller Ø 20 mm	Technopolymer roller Ø 20 mm	Porcelain roller	Adjustable safety actuator with technopolymer roller	Technopolymer roller Ø 20 mm	
VF L51 ⊕	VF L52 ⊕	VF L53 ⊕ (2)	VF L56 ⊕ (3)	VF L57 ⊕	

All values in the drawings are in mm

Accessories See page 207

→ The 2D and 3D files are available at [www.pizzato.com](http://www.pizzato.com)



## Special separate actuators

**IMPORTANT:** These separate actuators can be used only with items of the FD, FP, FL and FC series.

Steel rollers,  $\varnothing$  20 mm, with self-lubrication

VF L31-R24 (1)	VF L35-R24 (1) (3)	VF L51-R24 (1)	VF L52-R24 (1)	VF L56-R24 (3)	VF L57-R24 (1)

**Note:** To order with 316L stainless steel roller: replace R24 with R41 in the order numbers.

Technopolymer rollers,  $\varnothing$  35 mm

VF L31-R25 (4)	VF L35-R25 (1) (3)	VF L51-R25 (4)	VF L52-R25 (1)	VF L56-R25 (3)	VF L57-R25 (1)

Rubber rollers,  $\varnothing$  40 mm

VF L31-R5 (4)	VF L35-R5 (1) (3)	VF L51-R5 (4)	VF L52-R5 (1)	VF L56-R5 (3)	VF L57-R5 (4)

Rubber rollers,  $\varnothing$  50 mm

VF L31-R26 (4)	VF L35-R26 (1) (3)	VF L51-R26 (4)	VF L52-R26 (4)	VF L56-R26 (3)	VF L57-R26 (4)

Protruding rubber rollers,  $\varnothing$  50 mm

VF L35-R27 (1) (3)	VF L56-R27 (3)

- (1) Lever VF L35 can only be used in safety applications if adjusted to its max. length, as shown in the figure to the right. If an adjustable lever is required for safety applications, use the VF L56 adjustable safety lever.
- (2) The position switch obtained by assembling switch FC •58-M2 (e.g. FC 358-M2, FC 3358-M2, ...) with actuator VF L53 will not present the same travel diagrams and actuating forces as switch FC •53-E11M2 (e.g. FC 3353-E11M2, FC 3353-E11M2V9, ...)
- (3) If installed with switch FC •58-M2 (e.g. FC 358-M2, FC 3358-M2, ...) the actuator may hit the housing of the switch upon actuation. This possible interference depends on the fixing position of actuator and switch head.
- (4) The actuator cannot be rotated to the inside because it will hit the switch head upon actuation.

All values in the drawings are in mm

Accessories See page 207

→ The 2D and 3D files are available at [www.pizzato.com](http://www.pizzato.com)

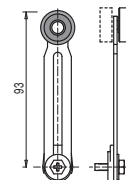

## Description



Pizzato Elettrica position switches are daily installed in every type of industrial machinery all over the world for applications in the sector of wood, metal, plastic, automotive, packaging, lifting, medicinal, naval, etc.

In order to be used in a wide variety of sectors and countries, Pizzato Elettrica position switches are designed to be assembled in a lot of configurations, thanks to a wide range of body shapes, dozens of contact blocks, hundreds of actuators and materials, different actuating forces and several fixing methods.

Pizzato Elettrica can offer one of the widest product range of position switches in the world. Moreover, the use of high quality materials, high reliability technologies (e.g. twin bridge contact blocks) as well as the IP69K or IP67 protection degree make this range of position switches one of the most technologically evolved.

## Updated design



The position switches for standard applications of the series FR, FK, FM and FX feature an updated design with rounded shapes and are now in anthracite grey, in line with the brand identity. All switches for standard applications are marked using laser technology. This provides lasting markings that are resistant to washing and wear.

## Hinged cover



The series FR, FM, FK and FX feature a hinged cover (equipped with built-in gasket and immovable captive screw) for easier, more practical wiring. With series FR and FK, once opened, the cover remains hooked onto the switch body. Use of a single screw to close the cover enables quicker wiring with the same hold.

## Metal fixing plates

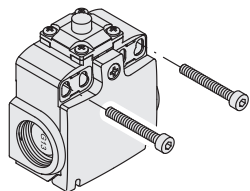

The technopolymer switches of the series FR, FK and FX are equipped with two robust metal plates on the mounting holes of the housings. This enables more reliable fixing of the switch without using washers under the screws. The fixing plates are made of thick zinc-plated steel; they are also available in stainless steel on request ("X" versions).

stainless steel on request ("X" versions).

## Protection degrees IP67 and IP69K

**IP69K**  
**IP67**

These devices are designed to be used under the toughest environmental conditions, and they pass the IP67 immersion test acc. to EN 60529. They can therefore be used in all environments where the maximum degree of protection is required for the housing.

All switches with actuator that do not have an external rubber hood also have a protection degree of IP69K in accordance with ISO 20653, and can be used on machinery subject to washing with water jets at 100 bar and 80°C.

## Reversible levers

For switches with swivelling lever, the lever can be fastened on straight or reverse side maintaining the positive coupling. In this way two different working planes of the lever are possible.

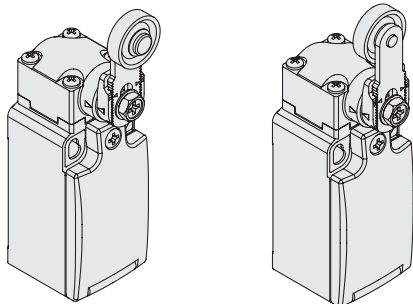

## Adjustable safety lever

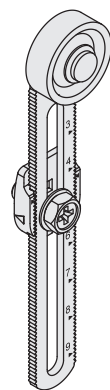

The adjustable lever code 56 (and variants) is provided with a notching that prevents the sliding also in case the fastening screw becomes loose.

Thanks to the special geometrical coupling it is suitable for safety applications.

## Adjustable levers

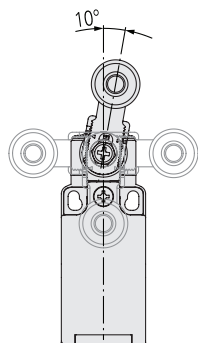

For switches with swivelling lever, the lever can be adjusted in 10° steps over the entire 360° range. The positive movement transmission is always guaranteed thanks to the particular geometrical coupling between the lever and the revolving shaft as prescribed for safety applications by the German standard BG-GS-ET-15.

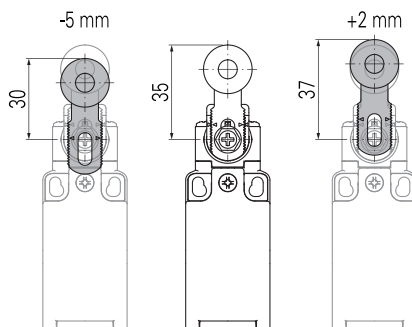

The switches equipped with swivelling lever with roller enable adjustment of lever height, along the length of the actuator, with increments of 1 mm. This enables compensation for variability of the fixings or structural work and precise final adjustment.

### Head with variable orientation

For all switches the head can be rotated in 90° steps.

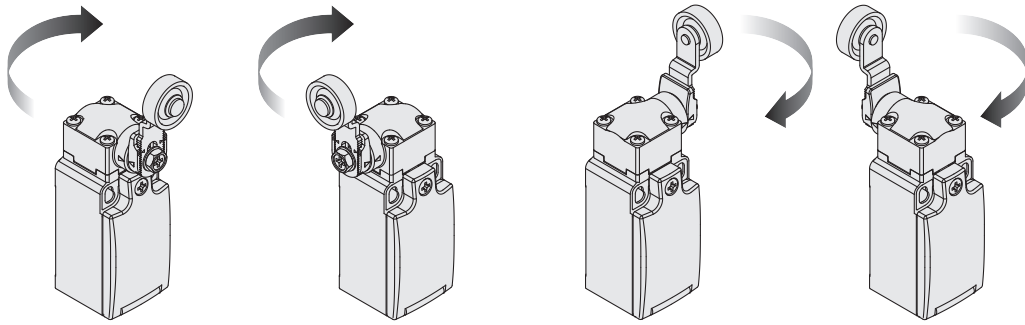

### Extended temperature range

**-40°C**

These devices are also available in a special version suitable for an ambient operating temperature range from -40°C up to +80°C.

They can therefore be used for applications in cold stores, sterilisers, and other equipment operated in very low-temperature environments. The special materials used to produce these versions retain their characteristics even under these conditions, thereby expanding the installation possibilities.

### Stainless steel external metallic parts

**STAINLESS STEEL**

Upon request, some of these devices can be supplied with stainless steel external metallic parts instead of the usual zinc-plated steel. This solution is particularly suited for environments where aggressive chemical agents or saline mist are present. The steel rollers of the actuators are available in the standard version made of steel with self-lubrication or in the version made of 316L stainless steel, which is preferred if even higher corrosion resistance is necessary. See page 201.

### Contact blocks

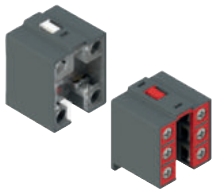

Contact blocks with captive screws, finger protection, twin bridge contacts and double interruption for higher contact reliability. They are available in multiple variants with shifted activation travels, simultaneous or overlapping. They are suitable for many different applications.

### Gold-plated contacts

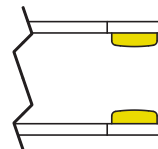

The contact blocks of these devices can be supplied gold-plated upon request. Ideal for applications with low voltages or currents; it ensures increased contact reliability. Available in two thicknesses (1 or 2.5 microns), it adapts perfectly to the various fields of application, ensuring a long endurance over time.

### Independent contacts

The contact block 16 is provided with two NC contacts, **both with positive opening**, that can be independently switched depending on the lever turning direction.

Lever turned to left

Contact diagram

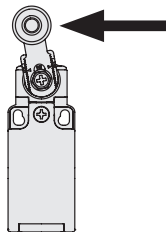
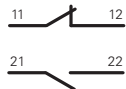

Lever not actuated

Contact diagram

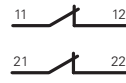

Lever turned to right

Contact diagram

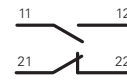

### Increased or reduced actuating force

For actuators with swivelling lever, versions with increased or reduced actuating force are available upon request, in order to have a switch perfectly tailored for the application. For further information contact our technical department.

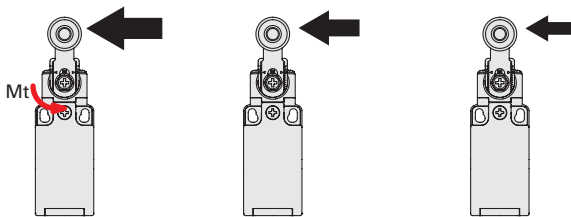

Increased force  
Mt = 0.1 Nm  
(E6 option)

Standard force  
Mt = 0.06 Nm

Reduced force  
Mt = 0.03 Nm  
(E0 option)

### Standard M20 thread

All switches for standard applications are also available in a version with conduit entry featuring standard M20 thread, enabling application of M12 4-pole or 8-pole connectors (metal and plastic) or M20 cable gland. Having a cable feed-through with a greater diameter, the M20 cable gland facilitates wiring of contact blocks.



Selection diagram

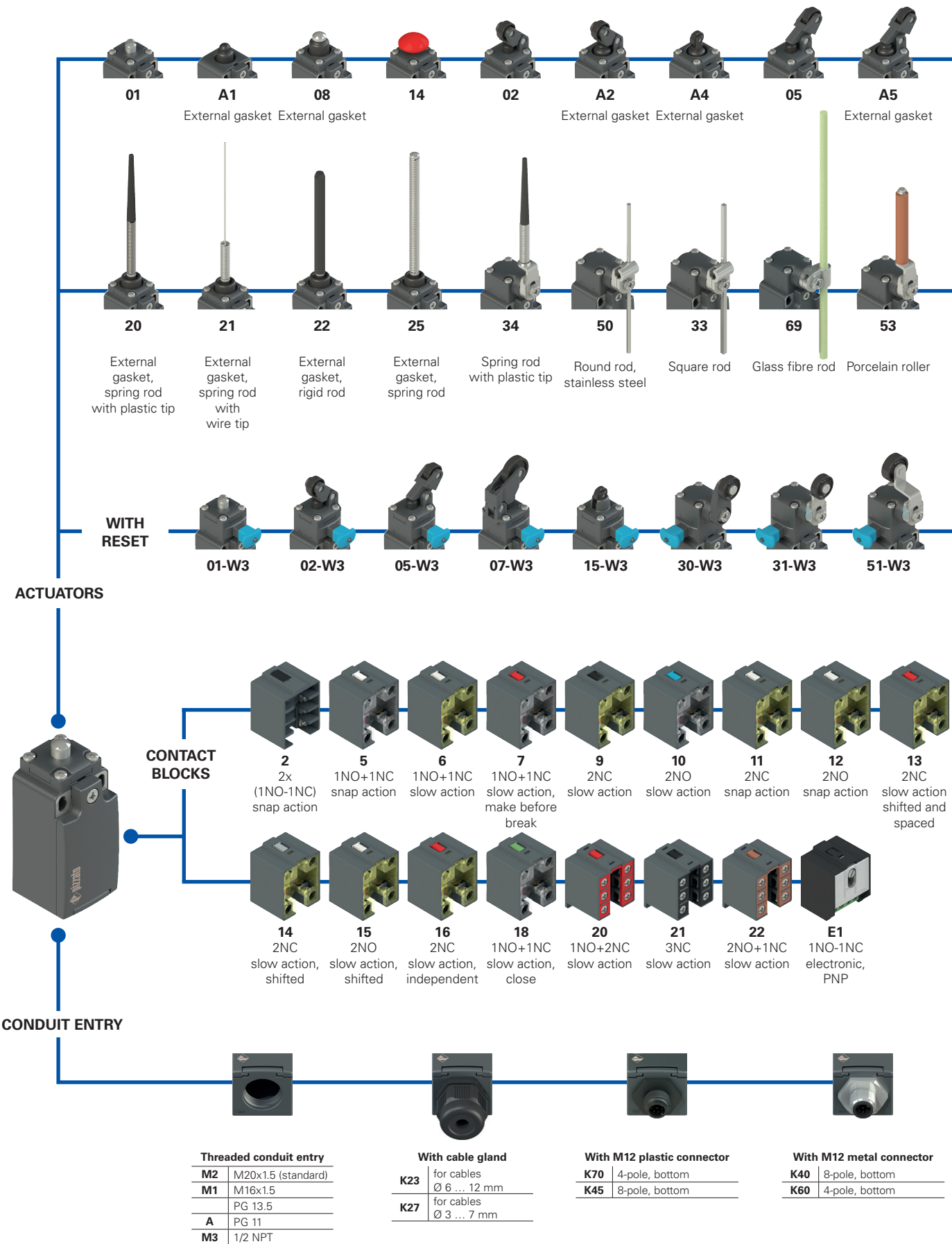

● Product options  
→ Sold separately as accessory



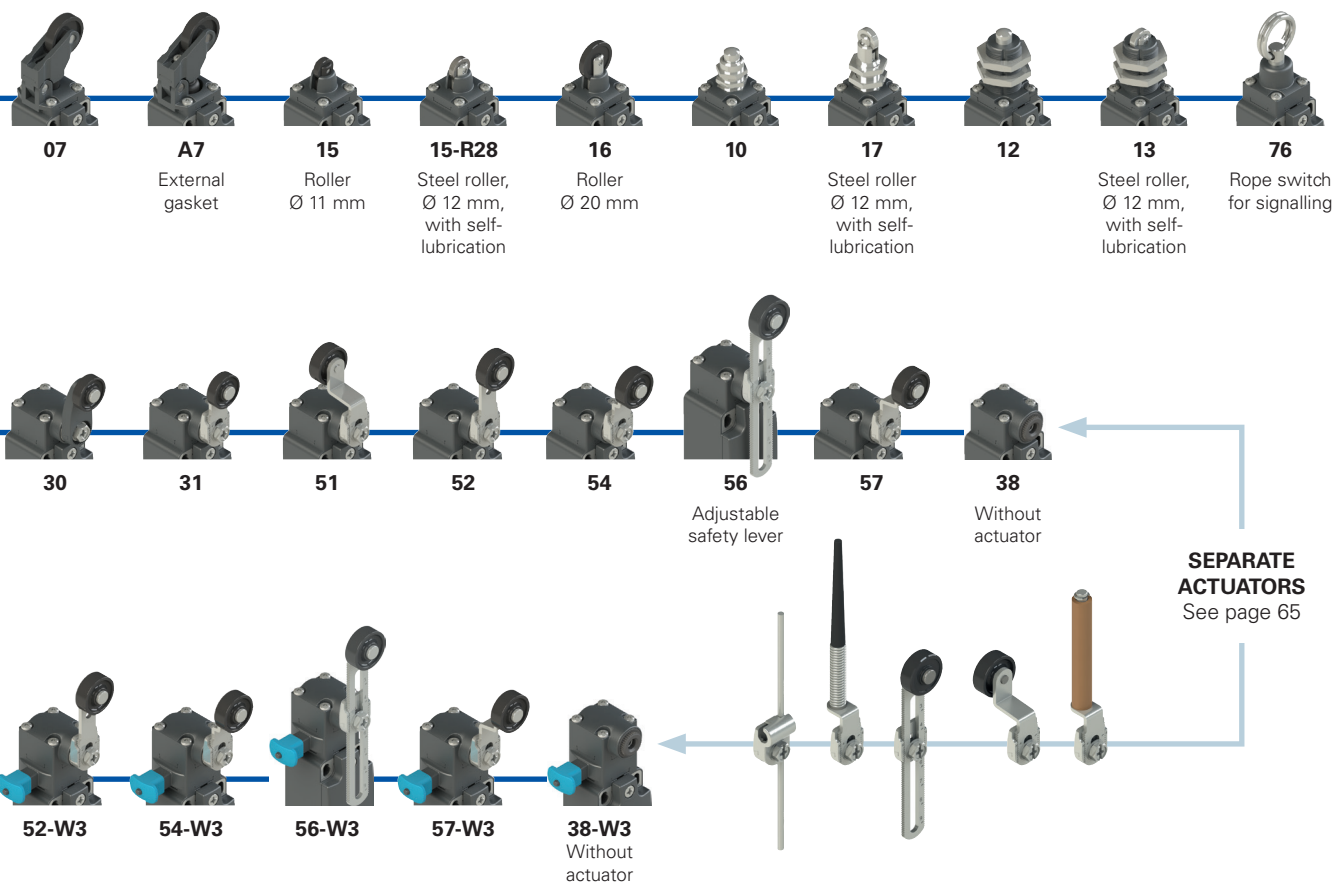

### Code structure

**Attention!** The feasibility of a code number does not mean the effective availability of a product. Please contact our sales office.

article options options  
**FR 502-W3XGM2K70R23T6**

#### Ambient temperature

	-25°C ... +80°C (standard)
<b>T6</b>	-40°C ... +80°C

Housing	
<b>FR</b>	technopolymer, one conduit entry
Contact block	
<b>5</b>	1NO+1NC, snap action
<b>6</b>	1NO+1NC, slow action
<b>7</b>	1NO+1NC, slow action, make before break
...	...

Actuators	
<b>01</b>	short plunger
<b>02</b>	roller lever
<b>05</b>	angled lever with roller
...	...

Reset	
	without reset (standard)
<b>W3</b>	simultaneous reset
<b>W4</b>	simultaneous reset, increased force

External metallic parts	
	zinc-plated steel (standard)
<b>X</b>	stainless steel

#### Pre-installed cable glands or connectors

	no cable gland or connector (standard)
<b>K23</b>	cable gland for cables Ø 6 ... 12 mm
<b>K70</b>	M12 plastic connector, 4-pole

For the complete list of possible combinations please contact our technical department.

#### Threaded conduit entry

<b>M2</b>	M20x1.5 (standard)
<b>M1</b>	M16x1.5
	PG 13.5
<b>A</b>	PG 11
<b>M3</b>	1/2 NPT

#### Contact type

	silver contacts (standard)
<b>G</b>	silver contacts, 1 µm gold coating
<b>G1</b>	silver contacts, 2.5 µm gold coating (not for contact block 2, 20, 21, 22)

#### Rollers

	standard roller
<b>R28</b>	Steel, with self-lubrication, Ø 12 mm (for actuators A4, 15)
<b>R44</b>	316L stainless steel, Ø 12 mm (for actuators A4, 13, 15, 17)
<b>R23</b>	Steel, with self-lubrication, Ø 14 mm (for actuators A2, 02, A5, 05, 30, 31, 51, 52, 54, 55, 56, 57)
<b>R43</b>	316L stainless steel, Ø 14 mm (for actuators A2, 02, A5, 05, 30, 31, 51, 52, 54, 55, 56, 57)
<b>R24</b>	Steel, with self-lubrication, Ø 20 mm (for actuators 30, 31, 51, 52, 54, 55, 56, 57)
<b>R41</b>	316L stainless steel, Ø 20 mm (for actuators 30, 31, 51, 52, 54, 55, 56, 57)
<b>R36</b>	Steel, with self-lubrication, Ø 16 mm (for actuators 30, 31, 51, 52, 54, 55, 56, 57)
<b>R25</b>	technopolymer, Ø 35 mm (for actuators 30, 31, 51, 52, 54, 55, 56, 57)
<b>R5</b>	rubber, Ø 40 mm (for actuators 30, 31, 51, 52, 54, 55, 56, 57)
<b>R26</b>	rubber, Ø 50 mm (for actuators 51, 52, 54, 55, 56, 57)
<b>R27</b>	rubber, protruding, Ø 50 mm (for actuators 55, 56)



### Main features

- Technopolymer housing, one conduit entry
- Hinged cover, fixed with single captive screw
- Metal plates on mounting holes of the housing
- Protection degree IP67 and up to IP69K for actuators without external gasket
- 17 contact blocks available
- 48 actuators available
- Versions with external parts in stainless steel
- Versions with M12 connector
- Versions with gold-plated silver contacts

### Quality marks:



IMQ approval:	EG610
UL approval:	E131787
CCC approval:	2021000305000101
EAC approval:	RU C-IT.YT03.B.00035/19

### Installation for safety applications:

Use only switches marked with the  $\ominus$  symbol beside the product code. Always connect the safety circuit to the **NC contacts** (normally closed contacts: 11-12, 21-22 or 31-32) as required by **EN ISO 14119, paragraph 5.4** for specific interlock applications and **EN ISO 13849-2 tables D3** (well-tried components) and **D.8** (fault exclusions) for safety applications in general. Actuate the switch **at least up to the positive opening travel** shown in the travel diagrams on page 232. Actuate the switch **at least with the positive opening force**, reported in brackets below each article, next to the actuating force value.

**⚠ If not expressly indicated in this chapter, for correct installation and utilization of all articles see the instructions given on pages 227 to 242.**

### Technical data

#### Housing

Housing made of glass fibre reinforced technopolymer, self-extinguishing, shock-proof and with double insulation:  $\square$

One threaded conduit entry:	M20x1.5 (standard)
Protection degree:	IP67 acc. to EN 60529 (with cable gland of equal or higher protection degree)
Protection degree with actuators 01, 02, 05, 07, 10, 12, 13, 14, 15, 15-R28, 16, 17, 30, 31, 33, 34, 38, 50, 51, 52, 53, 54, 56, 57, 69, 76:	IP69K acc. to ISO 20653 (with cable gland of equal or higher protection degree)

#### General data

Ambient temperature:	-25°C ... +80°C (standard) -40°C ... +80°C (T6 option)
Max. actuation frequency:	3600 operating cycles/hour
Mechanical endurance:	20 million operating cycles
Mounting position:	any
Safety parameter $B_{10D}$ :	40,000,000 for NC contacts
Mechanical interlock, not coded:	type 1 acc. to EN ISO 14119
Tightening torques for installation:	see page 231
Wire cross-sections and wire stripping lengths:	see page 249

#### In compliance with standards:

IEC 60947-5-1, EN 60947-5-1, EN 60947-1, EN 50047, IEC 60204-1, EN 60204-1, EN ISO 14119, EN ISO 12100, IEC 60529, EN 60529, EN IEC 63000, UL 508, CSA C22.2 No. 14.

#### Approvals:

IEC 60947-5-1, UL 508, CSA C22.2 No. 14, GB/T14048.5.

#### Compliance with the requirements of:

Low Voltage Directive 2014/35/EU, EMC Directive 2014/30/EU, RoHS Directive 2011/65/EU.

#### Positive contact opening in conformity with standards:

IEC 60947-5-1, EN 60947-5-1.

### Electrical data

### Utilization category

without connector	Thermal current ( $I_{th}$ ):	10 A	Alternating current: AC15 (50÷60 Hz)			
	Rated insulation voltage (U):	500 Vac 600 Vdc 400 Vac 500 Vdc (contact blocks 2, 11, 12, 20, 21, 22)	Ue (V)	250	400	500
	Rated impulse withstand voltage ( $U_{imp}$ ):	6 kV 4 kV (contact blocks 20, 21, 22)	Ie (A)	6	4	1
	Conditional short circuit current:	1000 A acc. to EN 60947-5-1	Direct current: DC13			
	Protection against short circuits:	type aM fuse 10 A 500 V	Ue (V)	24	125	250
Pollution degree:	3	Ie (A)	3	0.55	0.3	

with M12 connector, 4-pole	Thermal current ( $I_{th}$ ):	4 A	Alternating current: AC15 (50÷60 Hz)			
	Rated insulation voltage (U):	250 Vac 300 Vdc	Ue (V)	24	120	250
	Protection against short circuits:	type gG fuse 4 A 500 V	Ie (A)	4	4	4
	Pollution degree:	3	Direct current: DC13			
			Ue (V)	24	125	250
		Ie (A)	3	0.55	0.3	

with M12 connector, 8-pole	Thermal current ( $I_{th}$ ):	2 A	Alternating current: AC15 (50÷60 Hz)			
	Rated insulation voltage (U):	30 Vac 36 Vdc	Ue (V)	24		
	Protection against short circuits:	type gG fuse 2 A 500 V	Ie (A)	2		
	Pollution degree:	3	Direct current: DC13			
			Ue (V)	24		
		Ie (A)	2			



### Features approved by IMQ

Rated insulation voltage (Ui): 500 Vac  
 400 Vac (for contact blocks 2, 11, 12, 20, 21, 22, 28, 29, 30, 37, 33, 34)  
 Conventional free air thermal current (Ith): 10 A  
 Protection against short circuits: type aM fuse 10 A 500 V  
 Rated impulse withstand voltage (U<sub>imp</sub>): 6 kV  
 4 kV (for contact blocks 20, 21, 22, 28, 29, 30, 33, 34)  
 Protection degree of the housing: IP67  
 MV terminals (screw terminals)  
 Pollution degree: 3  
 Utilization category: AC15  
 Operating voltage (Ue): 400 Vac (50 Hz)  
 Operating current (Ie): 3 A  
 Forms of the contact element: Za, Za+Za, X+X, Zb, Y+Y, Y+Y+X, Y+Y+Y, Y+X+X, Y, X.  
 Positive opening of contacts on contact blocks 5, 6, 7, 8, 9, 11, 13, 14, 16, 17, 18, 19, 20, 21, 22, 28, 29, 30, 33, 34, 37, 38, 39, 66.  
 In compliance with standards: EN 60947-1, EN 60947-5-1, fundamental requirements of the Low Voltage Directive 2014/35/EU.

Please contact our technical department for the list of approved products.

### Features approved by UL

Electrical Ratings: Q300 pilot duty (69 VA, 125-250 V dc)  
 A600 pilot duty (720 VA, 120-600 V ac)  
 Environmental Ratings: Types 1, 4X  
 For all contact blocks except 2 and 3 use 60 or 75°C copper (Cu) conductors, rigid or flexible, wire size 12, 14 AWG. Tightening torque for terminal screws of 7.1 lb in (0.8 Nm).  
 For contact blocks 2 and 3 use 60 or 75°C copper (Cu) conductors, rigid or flexible, wire size 14 AWG. Tightening torque for terminal screws of 12 lb in (1.4 Nm).  
 The hub is to be connected to the conduit before the hub is connected to the enclosure.

Please contact our technical department for the list of approved products.

### Wiring diagram for M12 connectors

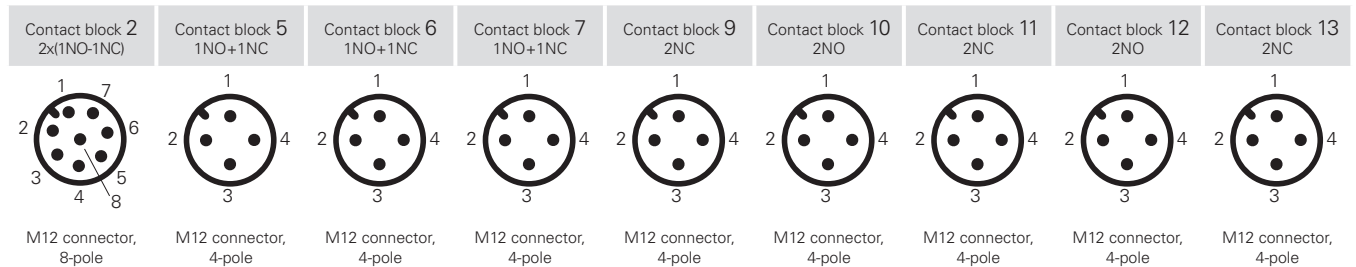

Contacts	Pin no.	Contacts	Pin no.	Contacts	Pin no.	Contacts	Pin no.	Contacts	Pin no.	Contacts	Pin no.	Contacts	Pin no.
NO	3-4	NC	1-2	NC	1-2	NC	1-2	NO	1-2	NC	1-2	NO	1-2
NC	5-6	NO	3-4	NO	3-4	NO	3-4	NC	3-4	NC	3-4	NO	3-4
NC	7-8												
NO	1-2												

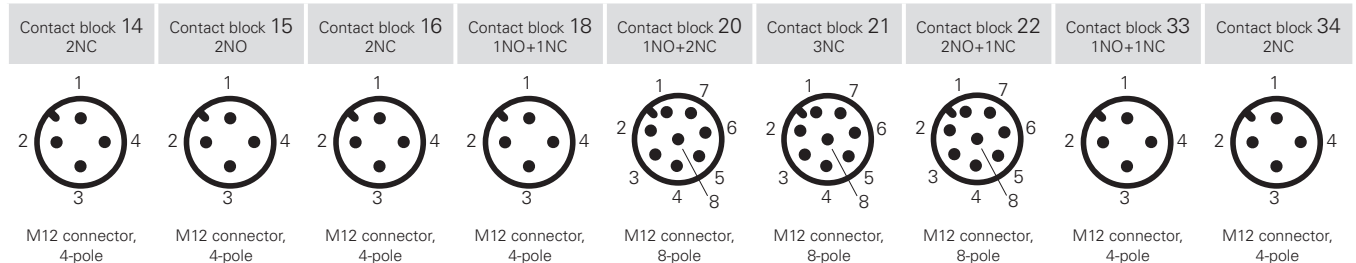

Contacts	Pin no.	Contacts	Pin no.	Contacts	Pin no.	Contacts	Pin no.	Contacts	Pin no.	Contacts	Pin no.	Contacts	Pin no.
NC (1°)	1-2	NO (1°)	1-2	NC, lever to the right	1-2	NC	1-2	NC	3-4	NC	3-4	NC	3-4
NC (2°)	3-4	NO (2°)	3-4	NC, lever to the left	3-4	NO	3-4	NC	5-6	NO	5-6	NO	3-4

Contact block E1  
PNP

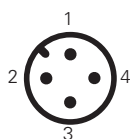

M12 connector, 4-pole

Contacts	Pin no.
+	1
-	3
NC	2
NO	4

# FR series position switches

- Contact type
- R** = snap action
  - L** = slow action
  - LO** = slow action, make before break
  - LS** = slow action, shifted
  - LV** = slow action, shifted and spaced
  - LI** = slow action, independent
  - LA** = slow action, close
  - △** = electronic, PNP

Contact block

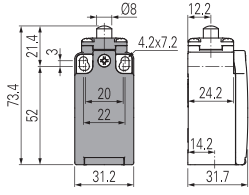

External gasket

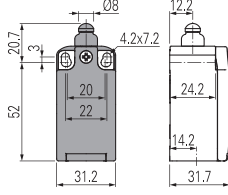

With steel roller with self-lubrication or 316L stainless steel on request

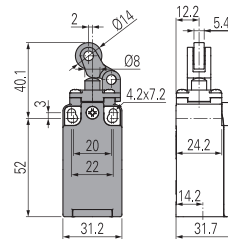

External gasket

With steel roller with self-lubrication or 316L stainless steel on request

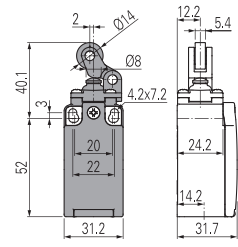

2	<b>R</b>	FR 201-M2	2x(1NO-1NC)	/	FR 202-M2	2x(1NO-1NC)	FR 2A2-M2	2x(1NO-1NC)	
5	<b>R</b>	FR 501-M2	⊕ 1NO+1NC	FR 5A1-M2	⊕ 1NO+1NC	FR 502-M2	⊕ 1NO+1NC	FR 5A2-M2	⊕ 1NO+1NC
6	<b>L</b>	FR 601-M2	⊕ 1NO+1NC	FR 6A1-M2	⊕ 1NO+1NC	FR 602-M2	⊕ 1NO+1NC	FR 6A2-M2	⊕ 1NO+1NC
7	<b>LO</b>	FR 701-M2	⊕ 1NO+1NC	FR 7A1-M2	⊕ 1NO+1NC	FR 702-M2	⊕ 1NO+1NC	FR 7A2-M2	⊕ 1NO+1NC
9	<b>L</b>	FR 901-M2	⊕ 2NC	FR 9A1-M2	⊕ 2NC	FR 902-M2	⊕ 2NC	FR 9A2-M2	⊕ 2NC
10	<b>L</b>	FR 1001-M2	2NO	FR 10A1-M2	2NO	FR 1002-M2	2NO	FR 10A2-M2	2NO
11	<b>R</b>	FR 1101-M2	⊕ 2NC	FR 11A1-M2	⊕ 2NC	FR 1102-M2	⊕ 2NC	FR 11A2-M2	⊕ 2NC
12	<b>R</b>	FR 1201-M2	2NO	FR 12A1-M2	2NO	FR 1202-M2	2NO	FR 12A2-M2	2NO
13	<b>LV</b>	FR 1301-M2	⊕ 2NC	FR 13A1-M2	⊕ 2NC	FR 1302-M2	⊕ 2NC	FR 13A2-M2	⊕ 2NC
14	<b>LS</b>	FR 1401-M2	⊕ 2NC	FR 14A1-M2	⊕ 2NC	FR 1402-M2	⊕ 2NC	FR 14A2-M2	⊕ 2NC
15	<b>LS</b>	FR 1501-M2	2NO	FR 15A1-M2	2NO	FR 1502-M2	2NO	FR 15A2-M2	2NO
18	<b>LA</b>	FR 1801-M2	⊕ 1NO+1NC	FR 18A1-M2	⊕ 1NO+1NC	FR 1802-M2	⊕ 1NO+1NC	FR 18A2-M2	⊕ 1NO+1NC
20	<b>L</b>	FR 2001-M2	⊕ 1NO+2NC	FR 20A1-M2	⊕ 1NO+2NC	FR 2002-M2	⊕ 1NO+2NC	FR 20A2-M2	⊕ 1NO+2NC
21	<b>L</b>	FR 2101-M2	⊕ 3NC	FR 21A1-M2	⊕ 3NC	FR 2102-M2	⊕ 3NC	FR 21A2-M2	⊕ 3NC
22	<b>L</b>	FR 2201-M2	⊕ 2NO+1NC	FR 22A1-M2	⊕ 2NO+1NC	FR 2202-M2	⊕ 2NO+1NC	FR 22A2-M2	⊕ 2NO+1NC
E1	<b>△</b>	FR E101-M2	1NO-1NC	FR E1A1-M2	1NO-1NC	FR E102-M2	1NO-1NC	FR E1A2-M2	1NO-1NC
Max. speed	page 231 - type 4			page 231 - type 4			page 231 - type 3		
Actuating force	8 N (25 N ⊕)			6 N (25 N ⊕)			6 N (25 N ⊕)		
Travel diagrams	page 232 - group 1			page 232 - group 1			page 232 - group 2		

- Contact type
- R** = snap action
  - L** = slow action
  - LO** = slow action, make before break
  - LS** = slow action, shifted
  - LV** = slow action, shifted and spaced
  - LI** = slow action, independent
  - LA** = slow action, close
  - △** = electronic, PNP

Contact block

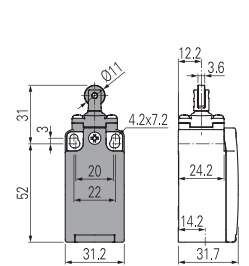

With steel roller with self-lubrication or 316L stainless steel on request

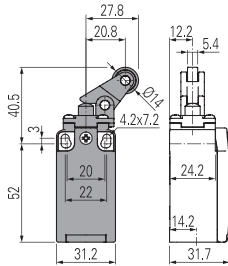

External gasket

With steel roller with self-lubrication or 316L stainless steel on request

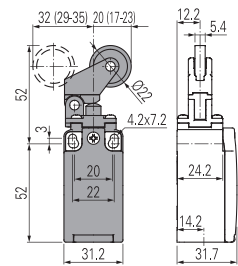
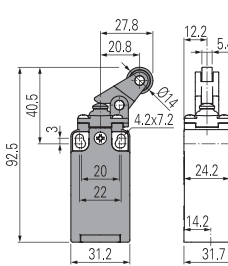

2	<b>R</b>	FR 2A4-M2	2x(1NO-1NC)	FR 205-M2	2x(1NO-1NC)	FR 2A5-M2	2x(1NO-1NC)	FR 207-M2	2x(1NO-1NC)
5	<b>R</b>	FR 5A4-M2	⊕ 1NO+1NC	FR 505-M2	⊕ 1NO+1NC	FR 5A5-M2	⊕ 1NO+1NC	FR 507-M2	⊕ 1NO+1NC
6	<b>L</b>	FR 6A4-M2	⊕ 1NO+1NC	FR 605-M2	⊕ 1NO+1NC	FR 6A5-M2	⊕ 1NO+1NC	FR 607-M2	⊕ 1NO+1NC
7	<b>LO</b>	FR 7A4-M2	⊕ 1NO+1NC	FR 705-M2	⊕ 1NO+1NC	FR 7A5-M2	⊕ 1NO+1NC	FR 707-M2	⊕ 1NO+1NC
9	<b>L</b>	FR 9A4-M2	⊕ 2NC	FR 905-M2	⊕ 2NC	FR 9A5-M2	⊕ 2NC	FR 907-M2	⊕ 2NC
10	<b>L</b>	FR 10A4-M2	2NO	FR 1005-M2	2NO	FR 10A5-M2	2NO	FR 1007-M2	2NO
11	<b>R</b>	FR 11A4-M2	⊕ 2NC	FR 1105-M2	⊕ 2NC	FR 11A5-M2	⊕ 2NC	FR 1107-M2	⊕ 2NC
12	<b>R</b>	FR 12A4-M2	2NO	FR 1205-M2	2NO	FR 12A5-M2	2NO	FR 1207-M2	2NO
13	<b>LV</b>	FR 13A4-M2	⊕ 2NC	FR 1305-M2	⊕ 2NC	FR 13A5-M2	⊕ 2NC	FR 1307-M2	⊕ 2NC
14	<b>LS</b>	FR 14A4-M2	⊕ 2NC	FR 1405-M2	⊕ 2NC	FR 14A5-M2	⊕ 2NC	FR 1407-M2	⊕ 2NC
15	<b>LS</b>	FR 15A4-M2	2NO	FR 1505-M2	2NO	FR 15A5-M2	2NO	FR 1507-M2	2NO
18	<b>LA</b>	FR 18A4-M2	⊕ 1NO+1NC	FR 1805-M2	⊕ 1NO+1NC	FR 18A5-M2	⊕ 1NO+1NC	FR 1807-M2	⊕ 1NO+1NC
20	<b>L</b>	FR 20A4-M2	⊕ 1NO+2NC	FR 2005-M2	⊕ 1NO+2NC	FR 20A5-M2	⊕ 1NO+2NC	FR 2007-M2	⊕ 1NO+2NC
21	<b>L</b>	FR 21A4-M2	⊕ 3NC	FR 2105-M2	⊕ 3NC	FR 21A5-M2	⊕ 3NC	FR 2107-M2	⊕ 3NC
22	<b>L</b>	FR 22A4-M2	⊕ 2NO+1NC	FR 2205-M2	⊕ 2NO+1NC	FR 22A5-M2	⊕ 2NO+1NC	FR 2207-M2	⊕ 2NO+1NC
E1	<b>△</b>	FR E1A4-M2	1NO-1NC	FR E105-M2	1NO-1NC	FR E1A5-M2	1NO-1NC	FR E107-M2	1NO-1NC
Max. speed	page 231 - type 5			page 231 - type 3			page 231 - type 3		
Actuating force	6 N (25 N ⊕)			6 N (25 N ⊕)			4.3 N (25 N ⊕)		
Travel diagrams	page 232 - group 1			page 232 - group 2			page 232 - group 3		

All values in the drawings are in mm

Accessories See page 207

→ The 2D and 3D files are available at [www.pizzato.com](http://www.pizzato.com)



Contact type	External gasket		External gasket		Secured only by means of threaded head in vertical position	
	<ul style="list-style-type: none"> <li><b>R</b> = snap action</li> <li><b>L</b> = slow action</li> <li><b>LO</b> = slow action, make before break</li> <li><b>LS</b> = slow action, shifted</li> <li><b>LV</b> = slow action, shifted and spaced</li> <li><b>LI</b> = slow action, independent</li> <li><b>LA</b> = slow action, close</li> <li><b>⚡</b> = electronic, PNP</li> </ul>					
Contact block						
2 <b>R</b>	FR 2A7-M2	2x(1NO-1NC)	FR 208-M2	2x(1NO-1NC)	FR 210-M2	2x(1NO-1NC)
5 <b>R</b>	FR 5A7-M2	⊕ 1NO+1NC	FR 508-M2	⊕ 1NO+1NC	FR 510-M2	⊕ 1NO+1NC
6 <b>L</b>	FR 6A7-M2	⊕ 1NO+1NC	FR 608-M2	⊕ 1NO+1NC	FR 610-M2	⊕ 1NO+1NC
7 <b>LO</b>	FR 7A7-M2	⊕ 1NO+1NC	FR 708-M2	⊕ 1NO+1NC	FR 710-M2	⊕ 1NO+1NC
9 <b>L</b>	FR 9A7-M2	⊕ 2NC	FR 908-M2	⊕ 2NC	FR 910-M2	⊕ 2NC
10 <b>L</b>	FR 10A7-M2	2NO	FR 1008-M2	2NO	FR 1010-M2	2NO
11 <b>R</b>	FR 11A7-M2	⊕ 2NC	FR 1108-M2	⊕ 2NC	FR 1110-M2	⊕ 2NC
12 <b>R</b>	FR 12A7-M2	2NO	FR 1208-M2	2NO	FR 1210-M2	2NO
13 <b>LV</b>	FR 13A7-M2	⊕ 2NC	FR 1308-M2	⊕ 2NC	FR 1310-M2	⊕ 2NC
14 <b>LS</b>	FR 14A7-M2	⊕ 2NC	FR 1408-M2	⊕ 2NC	FR 1410-M2	⊕ 2NC
15 <b>LS</b>	FR 15A7-M2	2NO	FR 1508-M2	2NO	FR 1510-M2	2NO
18 <b>LA</b>	FR 18A7-M2	⊕ 1NO+1NC	FR 1808-M2	⊕ 1NO+1NC	FR 1810-M2	⊕ 1NO+1NC
20 <b>L</b>	FR 20A7-M2	⊕ 1NO+2NC	FR 2008-M2	⊕ 1NO+2NC	FR 2010-M2	⊕ 1NO+2NC
21 <b>L</b>	FR 21A7-M2	⊕ 3NC	FR 2108-M2	⊕ 3NC	FR 2110-M2	⊕ 3NC
22 <b>L</b>	FR 22A7-M2	⊕ 2NO+1NC	FR 2208-M2	⊕ 2NO+1NC	FR 2210-M2	⊕ 2NO+1NC
E1 <b>⚡</b>	FR E1A7-M2	1NO-1NC	FR E108-M2	1NO-1NC	FR E110-M2	1NO-1NC
Max. speed	page 231 - type 3		page 231 - type 4		page 231 - type 4	
Actuating force	3 N (25 N ⊕)		8 N (25 N ⊕)		8 N (25 N ⊕)	
Travel diagrams	page 232 - group 3		page 232 - group 1		page 232 - group 1	

Contact type	Roller, Ø 11 mm, technopolymer		Steel roller, Ø 12 mm, with self-lubrication With 316L stainless steel roller on request	
	<ul style="list-style-type: none"> <li><b>R</b> = snap action</li> <li><b>L</b> = slow action</li> <li><b>LO</b> = slow action, make before break</li> <li><b>LS</b> = slow action, shifted</li> <li><b>LV</b> = slow action, shifted and spaced</li> <li><b>LI</b> = slow action, independent</li> <li><b>LA</b> = slow action, close</li> <li><b>⚡</b> = electronic, PNP</li> </ul>			
Contact block				
2 <b>R</b>	FR 213-M2	2x(1NO-1NC)	FR 214-M2	2x(1NO-1NC)
5 <b>R</b>	FR 513-M2	⊕ 1NO+1NC	FR 514-M2	⊕ 1NO+1NC
6 <b>L</b>	FR 613-M2	⊕ 1NO+1NC	FR 614-M2	⊕ 1NO+1NC
7 <b>LO</b>	FR 713-M2	⊕ 1NO+1NC	FR 714-M2	⊕ 1NO+1NC
9 <b>L</b>	FR 913-M2	⊕ 2NC	FR 914-M2	⊕ 2NC
10 <b>L</b>	FR 1013-M2	2NO	FR 1014-M2	2NO
11 <b>R</b>	FR 1113-M2	⊕ 2NC	FR 1114-M2	⊕ 2NC
12 <b>R</b>	FR 1213-M2	2NO	FR 1214-M2	2NO
13 <b>LV</b>	FR 1313-M2	⊕ 2NC	FR 1314-M2	⊕ 2NC
14 <b>LS</b>	FR 1413-M2	⊕ 2NC	FR 1414-M2	⊕ 2NC
15 <b>LS</b>	FR 1513-M2	2NO	FR 1514-M2	2NO
18 <b>LA</b>	FR 1813-M2	⊕ 1NO+1NC	FR 1814-M2	⊕ 1NO+1NC
20 <b>L</b>	FR 2013-M2	⊕ 1NO+2NC	FR 2014-M2	⊕ 1NO+2NC
21 <b>L</b>	FR 2113-M2	⊕ 3NC	FR 2114-M2	⊕ 3NC
22 <b>L</b>	FR 2213-M2	⊕ 2NO+1NC	FR 2214-M2	⊕ 2NO+1NC
E1 <b>⚡</b>	FR E113-M2	1NO-1NC	FR E114-M2	1NO-1NC
Max. speed	page 231 - type 2		page 231 - type 4	
Actuating force	8 N (25 N ⊕)		8 N (25 N ⊕)	
Travel diagrams	page 232 - group 1		page 232 - group 1	

All values in the drawings are in mm

Accessories See page 207

→ The 2D and 3D files are available at [www.pizzato.com](http://www.pizzato.com)

# FR series position switches

- Contact type
- R** = snap action
  - L** = slow action
  - LO** = slow action, make before break
  - LS** = slow action, shifted
  - LV** = slow action, shifted and spaced
  - LI** = slow action, independent
  - LA** = slow action, close
  - ⏏** = electronic, PNP

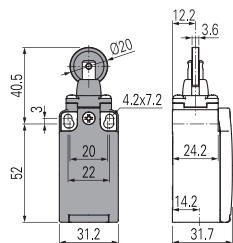

Secured only by means of threaded head in vertical position

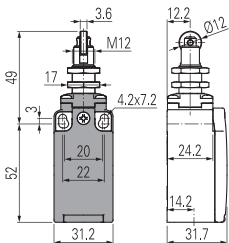

External gasket  
Spring rod

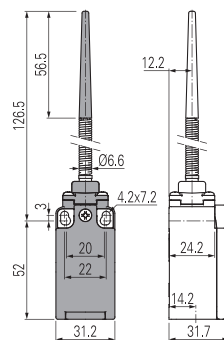

External gasket  
Spring rod

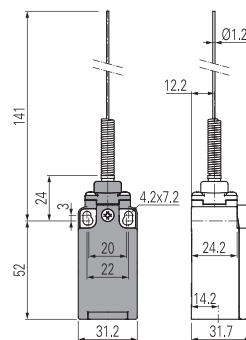

Contact block

2	<b>R</b>	FR 216-M2	2x(1NO-1NC)	FR 217-M2	2x(1NO-1NC)	FR 220-M2	2x(1NO-1NC)	FR 221-M2	2x(1NO-1NC)
5	<b>R</b>	FR 516-M2	⊕ 1NO+1NC	FR 517-M2	⊕ 1NO+1NC	FR 520-M2	1NO+1NC	FR 521-M2	1NO+1NC
6	<b>L</b>	FR 616-M2	⊕ 1NO+1NC	FR 617-M2	⊕ 1NO+1NC	/	/	/	/
7	<b>LO</b>	FR 716-M2	⊕ 1NO+1NC	FR 717-M2	⊕ 1NO+1NC	/	/	/	/
9	<b>L</b>	FR 916-M2	⊕ 2NC	FR 917-M2	⊕ 2NC	/	/	/	/
10	<b>L</b>	FR 1016-M2	2NO	FR 1017-M2	2NO	FR 1020-M2	2NO	FR 1021-M2	2NO
11	<b>R</b>	FR 1116-M2	⊕ 2NC	FR 1117-M2	⊕ 2NC	/	/	/	/
12	<b>R</b>	FR 1216-M2	2NO	FR 1217-M2	2NO	FR 1220-M2	2NO	FR 1221-M2	2NO
13	<b>LV</b>	FR 1316-M2	⊕ 2NC	FR 1317-M2	⊕ 2NC	/	/	/	/
14	<b>LS</b>	FR 1416-M2	⊕ 2NC	FR 1417-M2	⊕ 2NC	/	/	/	/
15	<b>LS</b>	FR 1516-M2	2NO	FR 1517-M2	2NO	/	/	/	/
18	<b>LA</b>	FR 1816-M2	⊕ 1NO+1NC	FR 1817-M2	⊕ 1NO+1NC	FR 1820-M2	1NO+1NC	FR 1821-M2	1NO+1NC
20	<b>L</b>	FR 2016-M2	⊕ 1NO+2NC	FR 2017-M2	⊕ 1NO+2NC	FR 2020-M2	1NO+2NC	FR 2021-M2	1NO+2NC
21	<b>L</b>	FR 2116-M2	⊕ 3NC	FR 2117-M2	⊕ 3NC	FR 2120-M2	3NC	FR 2121-M2	3NC
22	<b>L</b>	FR 2216-M2	⊕ 2NO+1NC	FR 2217-M2	⊕ 2NO+1NC	FR 2220-M2	2NO+1NC	FR 2221-M2	2NO+1NC
E1	<b>⏏</b>	FR E116-M2	1NO-1NC	FR E117-M2	1NO-1NC	FR E120-M2	1NO-1NC	FR E121-M2	1NO-1NC
Max. speed		page 231 - type 2		page 231 - type 2		1 m/s		1 m/s	
Actuating force		8 N (25 N ⊕)		8 N (25 N ⊕)		0.07 Nm		0.07 Nm	
Travel diagrams		page 232 - group 1		page 232 - group 1		page 232 - group 4		page 232 - group 4	

- Contact type
- R** = snap action
  - L** = slow action
  - LO** = slow action, make before break
  - LS** = slow action, shifted
  - LV** = slow action, shifted and spaced
  - LI** = slow action, independent
  - LA** = slow action, close
  - ⏏** = electronic, PNP

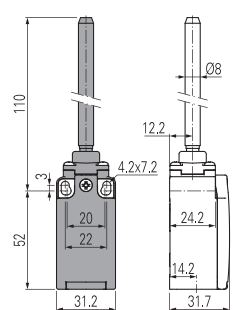

External gasket  
Spring rod

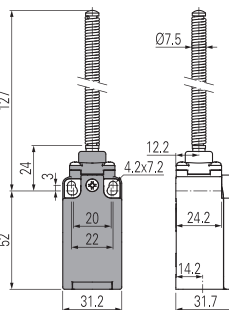

With Ø 20 mm steel roller with self-lubrication or 316L stainless steel on request

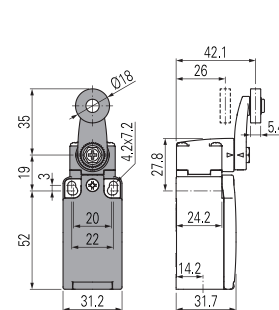

Other rollers available. See page 66

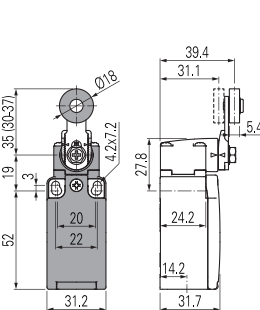

Contact block

2	<b>R</b>	FR 222-M2	2x(1NO-1NC)	FR 225-M2	2x(1NO-1NC)	FR 230-M2	2x(1NO-1NC)	FR 231-M2	2x(1NO-1NC)
5	<b>R</b>	/	/	FR 525-M2	1NO+1NC	FR 530-M2	⊕ 1NO+1NC	FR 531-M2	⊕ 1NO+1NC
6	<b>L</b>	/	/	/	/	FR 630-M2	⊕ 1NO+1NC	FR 631-M2	⊕ 1NO+1NC
7	<b>LO</b>	/	/	/	/	FR 730-M2	⊕ 1NO+1NC	FR 731-M2	⊕ 1NO+1NC
9	<b>L</b>	/	/	/	/	FR 930-M2	⊕ 2NC	FR 931-M2	⊕ 2NC
10	<b>L</b>	FR 1022-M2	2NO	FR 1025-M2	2NO	FR 1030-M2	2NO	FR 1031-M2	2NO
11	<b>R</b>	/	/	/	/	FR 1130-M2	⊕ 2NC	FR 1131-M2	⊕ 2NC
12	<b>R</b>	FR 1222-M2	2NO	FR 1225-M2	2NO	FR 1230-M2	2NO	FR 1231-M2	2NO
13	<b>LV</b>	/	/	/	/	FR 1330-M2	⊕ 2NC	FR 1331-M2	⊕ 2NC
14	<b>LS</b>	/	/	/	/	FR 1430-M2	⊕ 2NC	FR 1431-M2	⊕ 2NC
15	<b>LS</b>	/	/	/	/	FR 1530-M2	2NO	FR 1531-M2	2NO
16	<b>LI</b>	/	/	/	/	FR 1630-M2	⊕ 2NC	FR 1631-M2	⊕ 2NC
18	<b>LA</b>	FR 1822-M2	⊕ 1NO+1NC	FR 1825-M2	1NO+1NC	FR 1830-M2	⊕ 1NO+1NC	FR 1831-M2	⊕ 1NO+1NC
20	<b>L</b>	FR 2022-M2	⊕ 1NO+2NC	FR 2025-M2	1NO+2NC	FR 2030-M2	⊕ 1NO+2NC	FR 2031-M2	⊕ 1NO+2NC
21	<b>L</b>	FR 2122-M2	⊕ 3NC	FR 2125-M2	3NC	FR 2130-M2	⊕ 3NC	FR 2131-M2	⊕ 3NC
22	<b>L</b>	FR 2222-M2	⊕ 2NO+1NC	FR 2225-M2	2NO+1NC	FR 2230-M2	⊕ 2NO+1NC	FR 2231-M2	⊕ 2NO+1NC
E1	<b>⏏</b>	FR E122-M2	1NO-1NC	FR E125-M2	1NO-1NC	FR E130-M2	1NO-1NC	FR E131-M2	1NO-1NC
Max. speed		1 m/s		1 m/s		page 231 - type 1		page 231 - type 1	
Actuating force		0.12 Nm (0.25 Nm ⊕)		0.12 Nm		0.06 Nm (0.25 Nm ⊕)		0.06 Nm (0.25 Nm ⊕)	
Travel diagrams		page 232 - group 4		page 232 - group 4		page 232 - group 5		page 232 - group 5	

All values in the drawings are in mm

Accessories See page 207

→ The 2D and 3D files are available at [www.pizzato.com](http://www.pizzato.com)

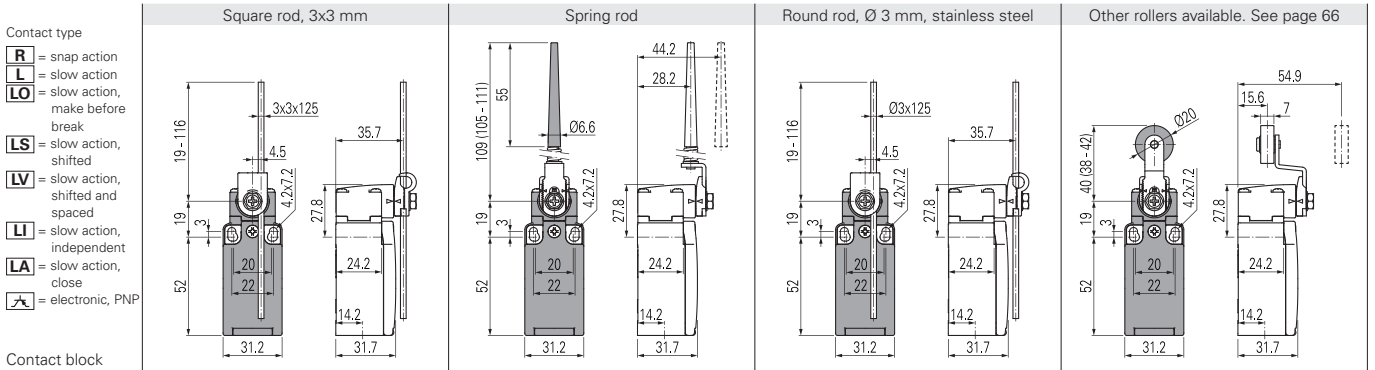

2	<b>R</b>	FR 233-M2	2x(1NO-1NC)	FR 234-M2	2x(1NO-1NC)	FR 250-M2	2x(1NO-1NC)	FR 251-M2	2x(1NO-1NC)
5	<b>R</b>	FR 533-M2	1NO+1NC	FR 534-M2	1NO+1NC	FR 550-M2	1NO+1NC	FR 551-M2	1NO+1NC ⊕
6	<b>L</b>	FR 633-M2	1NO+1NC	FR 634-M2	1NO+1NC	FR 650-M2	1NO+1NC	FR 651-M2	1NO+1NC ⊕
7	<b>LO</b>	FR 733-M2	1NO+1NC	FR 734-M2	1NO+1NC	FR 750-M2	1NO+1NC	FR 751-M2	1NO+1NC ⊕
9	<b>L</b>	FR 933-M2	2NC	FR 934-M2	2NC	FR 950-M2	2NC	FR 951-M2	2NC ⊕
10	<b>L</b>	FR 1033-M2	2NO	FR 1034-M2	2NO	FR 1050-M2	2NO	FR 1051-M2	2NO
11	<b>R</b>	FR 1133-M2	2NC	FR 1134-M2	2NC	FR 1150-M2	2NC	FR 1151-M2	2NC ⊕
12	<b>R</b>	FR 1233-M2	2NO	FR 1234-M2	2NO	FR 1250-M2	2NO	FR 1251-M2	2NO
13	<b>LV</b>	FR 1333-M2	2NC	FR 1334-M2	2NC	FR 1350-M2	2NC	FR 1351-M2	2NC ⊕
14	<b>LS</b>	FR 1433-M2	2NC	FR 1434-M2	2NC	FR 1450-M2	2NC	FR 1451-M2	2NC ⊕
15	<b>LS</b>	FR 1533-M2	2NO	FR 1534-M2	2NO	FR 1550-M2	2NO	FR 1551-M2	2NO
16	<b>LI</b>	FR 1633-M2	2NC	FR 1634-M2	2NC	FR 1650-M2	2NC	FR 1651-M2	2NC ⊕
18	<b>LA</b>	FR 1833-M2	1NO+1NC	FR 1834-M2	1NO+1NC	FR 1850-M2	1NO+1NC	FR 1851-M2	1NO+1NC ⊕
20	<b>L</b>	FR 2033-M2	1NO+2NC	FR 2034-M2	1NO+2NC	FR 2050-M2	1NO+2NC	FR 2051-M2	1NO+2NC ⊕
21	<b>L</b>	FR 2133-M2	3NC	FR 2134-M2	3NC	FR 2150-M2	3NC	FR 2151-M2	3NC ⊕
22	<b>L</b>	FR 2233-M2	2NO+1NC	FR 2234-M2	2NO+1NC	FR 2250-M2	2NO+1NC	FR 2251-M2	2NO+1NC ⊕
E1	<b>⌘</b>	FR E133-M2	1NO-1NC	FR E134-M2	1NO-1NC	FR E150-M2	1NO-1NC	FR E151-M2	1NO-1NC
Max. speed		1.5 m/s		1.5 m/s		1.5 m/s		page 231 - type 1	
Actuating force		0.06 Nm		0.06 Nm		0.06 Nm		0.06 Nm (0.25 Nm ⊕)	
Travel diagrams		page 232 - group 5		page 232 - group 5		page 232 - group 5		page 232 - group 5	

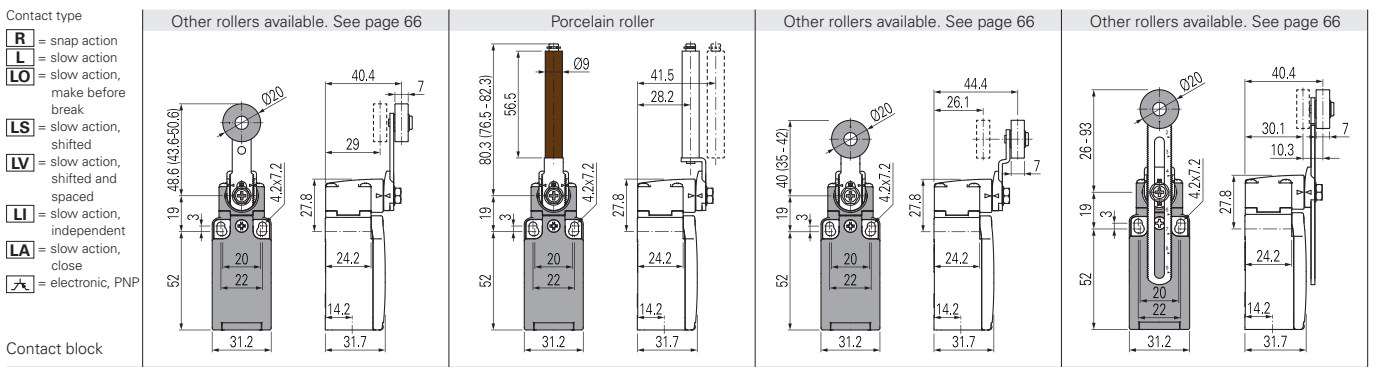

2	<b>R</b>	FR 252-M2	2x(1NO-1NC)	FR 253-E0M2	2x(1NO-1NC)	FR 254-M2	2x(1NO-1NC)	FR 256-M2	2x(1NO-1NC)
5	<b>R</b>	FR 552-M2	1NO+1NC ⊕	FR 553-E0M2V9	1NO+1NC ⊕	FR 554-M2	1NO+1NC ⊕	FR 556-M2	1NO+1NC ⊕
6	<b>L</b>	FR 652-M2	1NO+1NC ⊕	FR 653-E0M2V9	1NO+1NC ⊕	FR 654-M2	1NO+1NC ⊕	FR 656-M2	1NO+1NC ⊕
7	<b>LO</b>	FR 752-M2	1NO+1NC ⊕	FR 753-E0M2V9	1NO+1NC ⊕	FR 754-M2	1NO+1NC ⊕	FR 756-M2	1NO+1NC ⊕
9	<b>L</b>	FR 952-M2	2NC ⊕	FR 953-E0M2V9	2NC	FR 954-M2	2NC ⊕	FR 956-M2	2NC ⊕
10	<b>L</b>	FR 1052-M2	2NO	FR 1053-E0M2V9	2NO	FR 1054-M2	2NO	FR 1056-M2	2NO
11	<b>R</b>	FR 1152-M2	2NC ⊕	/	/	FR 1154-M2	2NC ⊕	FR 1156-M2	2NC ⊕
12	<b>R</b>	FR 1252-M2	2NO	FR 1253-E0M2V9	2NO	FR 1254-M2	2NO	FR 1256-M2	2NO
13	<b>LV</b>	FR 1352-M2	2NC ⊕	FR 1353-E0M2V9	2NC ⊕	FR 1354-M2	2NC ⊕	FR 1356-M2	2NC ⊕
14	<b>LS</b>	FR 1452-M2	2NC ⊕	FR 1453-E0M2V9	2NC ⊕	FR 1454-M2	2NC ⊕	FR 1456-M2	2NC ⊕
15	<b>LS</b>	FR 1552-M2	2NO	FR 1553-E0M2V9	2NO	FR 1554-M2	2NO	FR 1556-M2	2NO
16	<b>LI</b>	FR 1652-M2	2NC ⊕	/	/	FR 1654-M2	2NC ⊕	FR 1656-M2	2NC ⊕
18	<b>LA</b>	FR 1852-M2	1NO+1NC ⊕	FR 1853-E0M2V9	1NO+1NC ⊕	FR 1854-M2	1NO+1NC ⊕	FR 1856-M2	1NO+1NC ⊕
20	<b>L</b>	FR 2052-M2	1NO+2NC ⊕	FR 2053-E0M2V9	1NO+2NC ⊕	FR 2054-M2	1NO+2NC ⊕	FR 2056-M2	1NO+2NC ⊕
21	<b>L</b>	FR 2152-M2	3NC ⊕	FR 2153-E0M2V9	3NC ⊕	FR 2154-M2	3NC ⊕	FR 2156-M2	3NC ⊕
22	<b>L</b>	FR 2252-M2	2NO+1NC ⊕	FR 2253-E0M2V9	2NO+1NC ⊕	FR 2254-M2	2NO+1NC ⊕	FR 2256-M2	2NO+1NC ⊕
E1	<b>⌘</b>	FR E152-M2	1NO-1NC	FR E153-E0M2V9	1NO-1NC	FR E154-M2	1NO-1NC	FR E156-M2	1NO-1NC
Max. speed		page 231 - type 1		0.5 m/s		page 231 - type 1		page 231 - type 1	
Actuating force		0.06 Nm (0.25 Nm ⊕)		0.03 Nm (0.25 Nm ⊕)		0.06 Nm (0.25 Nm ⊕)		0.06 Nm (0.25 Nm ⊕)	
Travel diagrams		page 232 - group 5		page 232 - group 6		page 232 - group 5		page 232 - group 5	

(1) Positive opening only with actuator set to max. See page 66.

All values in the drawings are in mm

Accessories See page 207

→ The 2D and 3D files are available at [www.pizzato.com](http://www.pizzato.com)

- Contact type
- R** = snap action
  - L** = slow action
  - LO** = slow action, make before break
  - LS** = slow action, shifted
  - LV** = slow action, shifted and spaced
  - LI** = slow action, independent
  - LA** = slow action, close
  - A** = electronic, PNP
- Contact block

		Other rollers available. See page 66	Glass fibre rod	Rope switch for signalling			
2	<b>R</b>	FR 257-M2	2x(1NO-1NC)	FR 269-M2	2x(1NO-1NC)	FR 276-M2	2x(1NO-1NC)
5	<b>R</b>	FR 557-M2	⊕ 1NO+1NC	FR 569-M2	1NO+1NC	FR 576-M2	1NO+1NC
6	<b>L</b>	FR 657-M2	⊕ 1NO+1NC	FR 669-M2	1NO+1NC	FR 676-M2	1NO+1NC
7	<b>LO</b>	FR 757-M2	⊕ 1NO+1NC	FR 769-M2	1NO+1NC	FR 776-M2	1NO+1NC
9	<b>L</b>	FR 957-M2	⊕ 2NC	FR 969-M2	2NC	FR 976-M2	2NO
10	<b>L</b>	FR 1057-M2	2NO	FR 1069-M2	2NO	FR 1076-M2	2NC
11	<b>R</b>	FR 1157-M2	⊕ 2NC	FR 1169-M2	2NC	FR 1176-M2	2NO
12	<b>R</b>	FR 1257-M2	2NO	FR 1269-M2	2NO	FR 1276-M2	2NC
13	<b>LV</b>	FR 1357-M2	⊕ 2NC	FR 1369-M2	2NC	FR 1376-M2	2NO
14	<b>LS</b>	FR 1457-M2	⊕ 2NC	FR 1469-M2	2NC	FR 1476-M2	2NO
15	<b>LS</b>	FR 1557-M2	2NO	FR 1569-M2	2NO	FR 1576-M2	2NC
16	<b>LI</b>	FR 1657-M2	⊕ 2NC	FR 1669-M2	2NC		/
18	<b>LA</b>	FR 1857-M2	⊕ 1NO+1NC	FR 1869-M2	1NO+1NC	FR 1876-M2	1NO+1NC
20	<b>L</b>	FR 2057-M2	⊕ 1NO+2NC	FR 2069-M2	1NO+2NC	FR 2076-M2	2NO+1NC
21	<b>L</b>	FR 2157-M2	⊕ 3NC	FR 2169-M2	3NC	FR 2176-M2	3NO
22	<b>L</b>	FR 2257-M2	⊕ 2NO+1NC	FR 2269-M2	2NO+1NC	FR 2276-M2	1NO+2NC
E1	<b>A</b>	FR E157-M2	1NO-1NC	FR E169-M2	1NO-1NC		/
Max. speed		page 231 - type 1		1.5 m/s		0.5 m/s	
Actuating force		0.06 Nm (0.25 Nm ⊕)		0.06 Nm		initial 20 N - final 40 N	
Travel diagrams		page 232 - group 5		page 232 - group 5		page 232 - group 7	

## FR series position switches with reset



The majority of switches can be equipped with a reset device (option W3) which enables the simultaneous actuation of actuator and contact block. The device is a module that is mounted between the body and the head of the switch that can be rotated independently from the head. The reset device has the following advantages:

- can be integrated into the majority of standard actuator heads;
- contact blocks with snap action are no more necessary because the tripping movement is executed by the reset device itself;
- can be rotated independently from the head ensuring maximum flexibility during installation;
- can be delivered with two different actuating forces: standard and increased for vibration applications;
- mechanical endurance: 1 million operating cycles.

- Contact type
- R** = snap action
  - L** = slow action

			With steel roller with self-lubrication or 316L stainless steel on request	With steel roller with self-lubrication or 316L stainless steel on request					
2	<b>R</b>	FR 201-W3M2	2x(1NO-1NC)	FR 202-W3M2	2x(1NO-1NC)	FR 205-W3M2	2x(1NO-1NC)	FR 207-W3M2	2x(1NO-1NC)
6	<b>L</b>	FR 601-W3M2	⊕ 1NO+1NC	FR 602-W3M2	⊕ 1NO+1NC	FR 605-W3M2	⊕ 1NO+1NC	FR 607-W3M2	⊕ 1NO+1NC
9	<b>L</b>	FR 901-W3M2	⊕ 2NC	FR 902-W3M2	⊕ 2NC	FR 905-W3M2	⊕ 2NC	FR 907-W3M2	⊕ 2NC
10	<b>L</b>	FR 1001-W3M2	2NO	FR 1002-W3M2	2NO	FR 1005-W3M2	2NO	FR 1007-W3M2	2NO
20	<b>L</b>	FR 2001-W3M2	⊕ 1NO+2NC	FR 2002-W3M2	⊕ 1NO+2NC	FR 2005-W3M2	⊕ 1NO+2NC	FR 2007-W3M2	⊕ 1NO+2NC
21	<b>L</b>	FR 2101-W3M2	⊕ 3NC	FR 2102-W3M2	⊕ 3NC	FR 2105-W3M2	⊕ 3NC	FR 2107-W3M2	⊕ 3NC
22	<b>L</b>	FR 2201-W3M2	⊕ 2NO+1NC	FR 2202-W3M2	⊕ 2NO+1NC	FR 2205-W3M2	⊕ 2NO+1NC	FR 2207-W3M2	⊕ 2NO+1NC
Max. speed		page 231 - type 4		page 231 - type 3		page 231 - type 3		page 231 - type 3	
Actuating force		4.5 N (25 N ⊕)		4 N (25 N ⊕)		4 N (25 N ⊕)		2.5 N (25 N ⊕)	
Travel diagrams		page 233 - group 1		page 233 - group 2		page 233 - group 2		page 233 - group 3	

All values in the drawings are in mm

Accessories See page 207

→ The 2D and 3D files are available at [www.pizzato.com](http://www.pizzato.com)





Contact type	With Ø 12 mm steel roller with self-lubrication or 316L stainless steel on request		With Ø 20 mm steel roller with self-lubrication or 316L stainless steel on request		Other rollers available. See page 66		Other rollers available. See page 66	
	<b>R</b> = snap action <b>L</b> = slow action							
Contact block								
2	<b>R</b>	FR 215-W3M2 2x(1NO-1NC)	FR 230-W3M2 2x(1NO-1NC)	FR 231-W3M2 2x(1NO-1NC)	FR 251-W3M2 2x(1NO-1NC)			
6	<b>L</b>	FR 615-W3M2 1NO+1NC	FR 630-W3M2 1NO+1NC	FR 631-W3M2 1NO+1NC	FR 651-W3M2 1NO+1NC			
9	<b>L</b>	FR 915-W3M2 2NC	FR 930-W3M2 2NC	FR 931-W3M2 2NC	FR 951-W3M2 2NC			
10	<b>L</b>	FR 1015-W3M2 2NO	FR 1030-W3M2 2NO	FR 1031-W3M2 2NO	FR 1051-W3M2 2NO			
20	<b>L</b>	FR 2015-W3M2 1NO+2NC	FR 2030-W3M2 1NO+2NC	FR 2031-W3M2 1NO+2NC	FR 2051-W3M2 1NO+2NC			
21	<b>L</b>	FR 2115-W3M2 3NC	FR 2130-W3M2 3NC	FR 2131-W3M2 3NC	FR 2151-W3M2 3NC			
22	<b>L</b>	FR 2215-W3M2 2NO+1NC	FR 2230-W3M2 2NO+1NC	FR 2231-W3M2 2NO+1NC	FR 2251-W3M2 2NO+1NC			
Max. speed	page 231 - type 2		page 231 - type 1		page 231 - type 1		page 231 - type 1	
Actuating force	4.5 N (25 N)		0.07 Nm (0.25 Nm)		0.07 Nm (0.25 Nm)		0.07 Nm (0.25 Nm)	
Travel diagrams	page 233 - group 1		page 233 - group 4		page 233 - group 4		page 233 - group 4	

Contact type	Other rollers available. See page 66		Other rollers available. See page 66		Other rollers available. See page 66		Other rollers available. See page 66	
	<b>R</b> = snap action <b>L</b> = slow action							
Contact block								
2	<b>R</b>	FR 252-W3M2 2x(1NO-1NC)	FR 254-W3M2 2x(1NO-1NC)	FR 256-W3M2 2x(1NO-1NC)	FR 257-W3M2 2x(1NO-1NC)			
6	<b>L</b>	FR 652-W3M2 1NO+1NC	FR 654-W3M2 1NO+1NC	FR 656-W3M2 1NO+1NC	FR 657-W3M2 1NO+1NC			
9	<b>L</b>	FR 952-W3M2 2NC	FR 954-W3M2 2NC	FR 956-W3M2 2NC	FR 957-W3M2 2NC			
10	<b>L</b>	FR 1052-W3M2 2NO	FR 1054-W3M2 2NO	FR 1056-W3M2 2NO	FR 1057-W3M2 2NO			
20	<b>L</b>	FR 2052-W3M2 1NO+2NC	FR 2054-W3M2 1NO+2NC	FR 2056-W3M2 1NO+2NC	FR 2057-W3M2 1NO+2NC			
21	<b>L</b>	FR 2152-W3M2 3NC	FR 2154-W3M2 3NC	FR 2156-W3M2 3NC	FR 2157-W3M2 3NC			
22	<b>L</b>	FR 2252-W3M2 2NO+1NC	FR 2254-W3M2 2NO+1NC	FR 2256-W3M2 2NO+1NC	FR 2257-W3M2 2NO+1NC			
Max. speed	page 231 - type 1		page 231 - type 1		page 231 - type 1		page 231 - type 1	
Actuating force	0.07 Nm (0.25 Nm)		0.07 Nm (0.25 Nm)		0.07 Nm (0.25 Nm)		0.07 Nm (0.25 Nm)	
Travel diagrams	page 233 - group 4		page 233 - group 4		page 233 - group 4		page 233 - group 4	

### Increased actuating force



The switch can be delivered with increased actuating force (option W4). Ideal for vibration applications.



Actuators	Actuating force
01, 14, 15, 16	7 N
02, 05	6 N
07	3.5 N
30 ... 57	0.08 Nm

To order the switch with reset and increased actuating force, replace the -W3 option with -W4 in the order code.

Example: FR 601-W3M2 → FR 601-W4M2

## Position switches with swivelling lever without actuator

- Contact type
- R** = snap action
  - L** = slow action
  - LO** = slow action, make before break
  - LS** = slow action, shifted
  - LV** = slow action, shifted and spaced
  - LI** = slow action, independent
  - LA** = slow action, close
  - A** = electronic, PNP

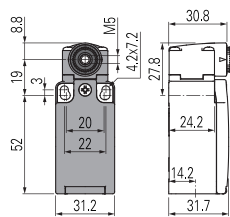

With manual reset knob

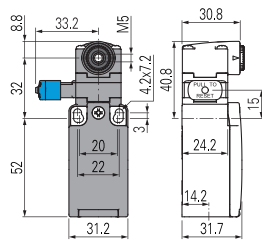

### IMPORTANT

**For safety applications:** join only switches and actuators marked with symbol next to the product code. For more information about safety applications see details on page 225.

Contact block	FR 238-M2	2x(1NO-1NC)	FR 238-W3M2	2x(1NO-1NC)
2	<b>R</b>		/	
5	<b>R</b>		/	
6	<b>L</b>		FR 638-W3M2	1NO+1NC
7	<b>LO</b>		/	
9	<b>L</b>		FR 938-W3M2	2NC
10	<b>L</b>		FR 1038-W3M2	2NO
11	<b>R</b>		/	
12	<b>R</b>		/	
13	<b>LV</b>		/	
14	<b>LS</b>		/	
15	<b>LS</b>		/	
16	<b>LI</b>		/	
18	<b>LA</b>		/	
20	<b>L</b>		FR 2038-W3M2	1NO+2NC
21	<b>L</b>		FR 2138-W3M2	3NC
22	<b>L</b>		FR 2238-W3M2	2NO+1NC
E1	<b>A</b>		/	
Actuating force	0.06 Nm (0.25 Nm		0.07 Nm (0.25 Nm	
Travel diagrams	page 232 - group 5		page 233 - group 4	

### Separate actuators

**IMPORTANT:** These separate actuators can be used only with items of the FR, FM, FX, FZ, FK, NA, NB and NF series.

Technopolymer roller Ø 18 mm	Technopolymer roller Ø 18 mm	Technopolymer roller Ø 14 mm	Technopolymer roller Ø 14 mm	Technopolymer roller Ø 20 mm	Technopolymer roller Ø 20 mm
VN A00KA	VN A00KB	VN A00KC	VN A00KD	VN A00KE	VN A00KF
Technopolymer roller Ø 20 mm	Technopolymer roller Ø 20 mm	Adjustable safety actuator with technopolymer roller	Adjustable square rod, 3x3x125 mm	Adjustable round rod Ø 3x125 mm	Adjustable glass fibre rod
VN A00KG	VN A00KH	VN A00KP	VN A00LB	VN A00LE	VN A00LH
Spring rod with plastic tip	Porcelain roller	Technopolymer roller Ø 14 mm	Technopolymer roller Ø 14 mm	Technopolymer roller Ø 20 mm	Adjustable safety lever with technopolymer roller Ø 20 mm
		With metallic parts in stainless steel			
VN A00LL	VN A00LP  (2)	VN A00KB-V38	VN A00KE-V38	VN A00KG-V38	VN A00KP-V38

All values in the drawings are in mm

Accessories See page 207

→ The 2D and 3D files are available at [www.pizzato.com](http://www.pizzato.com)

**Special separate actuators**
**IMPORTANT:** These separate actuators can be used only with items of the FR, FM, FX, FZ, FK, NA, NB and NF series.

Steel rollers, Ø 20 mm, with self-lubrication					
VN A00KB-R24 (1)	VN A00KE-R24 (1)	VN A00KF-R24 (1)	VN A00KG-R24 (1)	VN A00KH-R24 (1)	VN A00KP-R24 (1)

**Note:** To order with 316L stainless steel roller: replace R24 with R41 in the order numbers.

Technopolymer rollers, Ø 35 mm					
VN A00KB-R25 (1)	VN A00KE-R25 (1)	VN A00KF-R25 (1)	VN A00KG-R25 (1)	VN A00KH-R25 (1)	VN A00KP-R25 (1)

Rubber rollers, Ø 40 mm					
VN A00KB-R5 (1)	VN A00KE-R5 (1)	VN A00KF-R5 (1)	VN A00KG-R5 (1)	VN A00KH-R5 (1)	VN A00KP-R5 (1)

Rubber rollers, Ø 50 mm				
VN A00KE-R26 (1)	VN A00KF-R26 (1)	VN A00KG-R26 (1)	VN A00KH-R26 (1)	VN A00KP-R26 (1)

Protruding rubber rollers, Ø 50 mm
VN A00KP-R27 (1)

(1) The actuator cannot be rotated to the inside because it will hit the switch head upon actuation.

(2) The position switch obtained by assembling switch FR •38-M2 (e.g. FR 538-M2, FR 638-M2, ...) with actuator VN A00LP will not present the same travel diagrams and actuating forces as switch FR •53-E0M2V9 (e.g. FR 553-E0M2V9, FR 653-E0M2V9, ...)

**Note:** To check the correspondence with previous lever codes, please consult the table "Changed article codes" on page 289. Example: VF LE30 -> VN A00KA.

Selection diagram

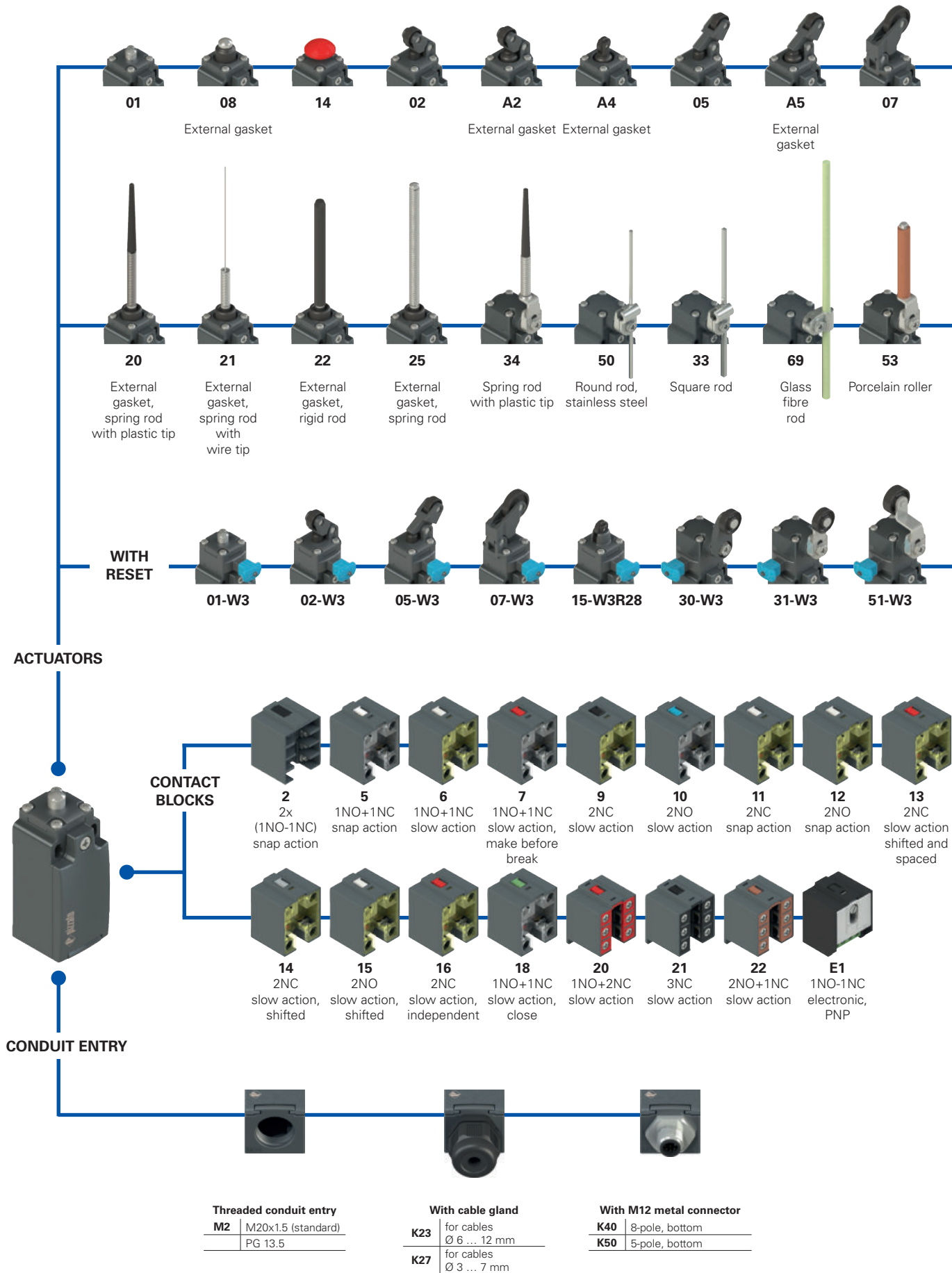

● Product options  
→ Sold separately as accessory



<b>A7</b> External gasket	<b>15-R28</b> Steel roller, Ø 12 mm, with self-lubrication	<b>16</b> Roller Ø 20 mm	<b>12</b>	<b>13</b> Steel roller, Ø 12 mm, with self-lubrication	<b>76</b> Rope switch for signalling
------------------------------	---	-----------------------------	-----------	---	---

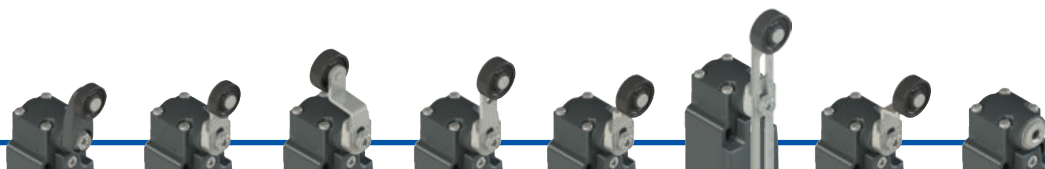

<b>30</b>	<b>31</b>	<b>51</b>	<b>52</b>	<b>54</b>	<b>56</b> Adjustable safety lever	<b>57</b>	<b>38</b> Without actuator
-----------	-----------	-----------	-----------	-----------	--------------------------------------	-----------	-------------------------------

**SEPARATE ACTUATORS**  
See page 77

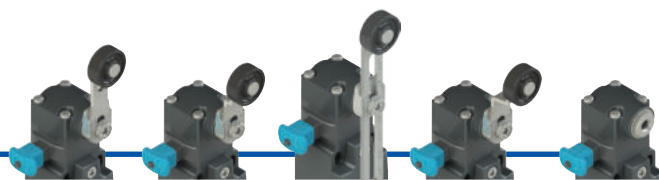

<b>52-W3</b>	<b>54-W3</b>	<b>56-W3</b>	<b>57-W3</b>	<b>38-W3</b> Without actuator
--------------	--------------	--------------	--------------	----------------------------------

### Code structure

**Attention!** The feasibility of a code number does not mean the effective availability of a product. Please contact our sales office.

	<table border="0" style="margin: auto;"> <tr> <td style="text-align: center; font-size: small;">article</td> <td style="text-align: center; font-size: small;">options</td> <td style="text-align: center; font-size: small;">options</td> </tr> <tr> <td colspan="3" style="text-align: center; font-size: 2em; font-weight: bold;">FM 502-W3GM2K50R23T6</td> </tr> </table>	article	options	options	FM 502-W3GM2K50R23T6																																					
article	options	options																																								
FM 502-W3GM2K50R23T6																																										
<table border="1" style="width: 100%; border-collapse: collapse;"> <tr><th colspan="2">Housing</th></tr> <tr><td><b>FM</b></td><td>metal, one conduit entry</td></tr> </table>	Housing		<b>FM</b>	metal, one conduit entry	<table border="1" style="width: 100%; border-collapse: collapse;"> <tr><th colspan="2">Contact block</th></tr> <tr><td><b>5</b></td><td>1NO+1NC, snap action</td></tr> <tr><td><b>6</b></td><td>1NO+1NC, slow action</td></tr> <tr><td><b>7</b></td><td>1NO+1NC, slow action, make before break</td></tr> <tr><td>...</td><td>...</td></tr> </table>	Contact block		<b>5</b>	1NO+1NC, snap action	<b>6</b>	1NO+1NC, slow action	<b>7</b>	1NO+1NC, slow action, make before break	...	...	<table border="1" style="width: 100%; border-collapse: collapse;"> <tr><th colspan="2">Ambient temperature</th></tr> <tr><td></td><td>-25°C ... +80°C (standard)</td></tr> <tr><td><b>T6</b></td><td>-40°C ... +80°C</td></tr> </table>	Ambient temperature			-25°C ... +80°C (standard)	<b>T6</b>	-40°C ... +80°C																				
Housing																																										
<b>FM</b>	metal, one conduit entry																																									
Contact block																																										
<b>5</b>	1NO+1NC, snap action																																									
<b>6</b>	1NO+1NC, slow action																																									
<b>7</b>	1NO+1NC, slow action, make before break																																									
...	...																																									
Ambient temperature																																										
	-25°C ... +80°C (standard)																																									
<b>T6</b>	-40°C ... +80°C																																									
<table border="1" style="width: 100%; border-collapse: collapse;"> <tr><th colspan="2">Actuators</th></tr> <tr><td><b>01</b></td><td>short plunger</td></tr> <tr><td><b>02</b></td><td>roller lever</td></tr> <tr><td><b>05</b></td><td>angled lever with roller</td></tr> <tr><td>...</td><td>...</td></tr> </table>	Actuators		<b>01</b>	short plunger	<b>02</b>	roller lever	<b>05</b>	angled lever with roller	...	...	<table border="1" style="width: 100%; border-collapse: collapse;"> <tr><th colspan="2">Reset</th></tr> <tr><td></td><td>without reset (standard)</td></tr> <tr><td><b>W3</b></td><td>simultaneous reset</td></tr> <tr><td><b>W4</b></td><td>simultaneous reset, increased force</td></tr> </table>	Reset			without reset (standard)	<b>W3</b>	simultaneous reset	<b>W4</b>	simultaneous reset, increased force	<table border="1" style="width: 100%; border-collapse: collapse;"> <tr><th colspan="2">Pre-installed cable glands or connectors</th></tr> <tr><td></td><td>no cable gland or connector (standard)</td></tr> <tr><td><b>K23</b></td><td>cable gland for cables Ø 6 ... 12 mm</td></tr> <tr><td><b>K50</b></td><td>M12 metal connector, 5-pole</td></tr> </table> <p style="font-size: x-small;">For the complete list of possible combinations please contact our technical department.</p>	Pre-installed cable glands or connectors			no cable gland or connector (standard)	<b>K23</b>	cable gland for cables Ø 6 ... 12 mm	<b>K50</b>	M12 metal connector, 5-pole														
Actuators																																										
<b>01</b>	short plunger																																									
<b>02</b>	roller lever																																									
<b>05</b>	angled lever with roller																																									
...	...																																									
Reset																																										
	without reset (standard)																																									
<b>W3</b>	simultaneous reset																																									
<b>W4</b>	simultaneous reset, increased force																																									
Pre-installed cable glands or connectors																																										
	no cable gland or connector (standard)																																									
<b>K23</b>	cable gland for cables Ø 6 ... 12 mm																																									
<b>K50</b>	M12 metal connector, 5-pole																																									
<table border="1" style="width: 100%; border-collapse: collapse;"> <tr><th colspan="2">Contact type</th></tr> <tr><td></td><td>silver contacts (standard)</td></tr> <tr><td><b>G</b></td><td>silver contacts, 1 µm gold coating</td></tr> <tr><td><b>G1</b></td><td>silver contacts, 2.5 µm gold coating (except contact blocks 2, 20, 21, 22)</td></tr> </table>	Contact type			silver contacts (standard)	<b>G</b>	silver contacts, 1 µm gold coating	<b>G1</b>	silver contacts, 2.5 µm gold coating (except contact blocks 2, 20, 21, 22)	<table border="1" style="width: 100%; border-collapse: collapse;"> <tr><th colspan="2">Threaded conduit entry</th></tr> <tr><td><b>M2</b></td><td>M20x1.5 (standard)</td></tr> <tr><td></td><td>PG 13.5</td></tr> </table>	Threaded conduit entry		<b>M2</b>	M20x1.5 (standard)		PG 13.5	<table border="1" style="width: 100%; border-collapse: collapse;"> <tr><th colspan="2">Rollers</th></tr> <tr><td></td><td>standard roller</td></tr> <tr><td><b>R28</b></td><td>Steel, with self-lubrication, Ø 12 mm (for actuators A4, 15)</td></tr> <tr><td><b>R44</b></td><td>316L stainless steel, Ø 12 mm (for actuators A4, 13, 15)</td></tr> <tr><td><b>R23</b></td><td>Steel, with self-lubrication, Ø 14 mm (for actuators A2, 02, A5, 05, 30, 31, 51, 52, 54, 55, 56, 57)</td></tr> <tr><td><b>R43</b></td><td>316L stainless steel, Ø 14 mm (for actuators A2, 02, A5, 05, 30, 31, 51, 52, 54, 55, 56, 57)</td></tr> <tr><td><b>R24</b></td><td>Steel, with self-lubrication, Ø 20 mm (for actuators 30, 31, 51, 52, 54, 55, 56, 57)</td></tr> <tr><td><b>R41</b></td><td>316L stainless steel, Ø 20 mm (for actuators 30, 31, 51, 52, 54, 55, 56, 57)</td></tr> <tr><td><b>R36</b></td><td>Steel, with self-lubrication, Ø 16 mm (for actuators 30, 31, 51, 52, 54, 55, 56, 57)</td></tr> <tr><td><b>R25</b></td><td>technopolymer, Ø 35 mm (for actuators 30, 31, 51, 52, 54, 55, 56, 57)</td></tr> <tr><td><b>R5</b></td><td>rubber, Ø 40 mm (for actuators 30, 31, 51, 52, 54, 55, 56, 57)</td></tr> <tr><td><b>R26</b></td><td>rubber, Ø 50 mm (for actuators 51, 52, 54, 55, 56, 57)</td></tr> <tr><td><b>R27</b></td><td>rubber, protruding, Ø 50 mm (for actuators 55, 56)</td></tr> </table>	Rollers			standard roller	<b>R28</b>	Steel, with self-lubrication, Ø 12 mm (for actuators A4, 15)	<b>R44</b>	316L stainless steel, Ø 12 mm (for actuators A4, 13, 15)	<b>R23</b>	Steel, with self-lubrication, Ø 14 mm (for actuators A2, 02, A5, 05, 30, 31, 51, 52, 54, 55, 56, 57)	<b>R43</b>	316L stainless steel, Ø 14 mm (for actuators A2, 02, A5, 05, 30, 31, 51, 52, 54, 55, 56, 57)	<b>R24</b>	Steel, with self-lubrication, Ø 20 mm (for actuators 30, 31, 51, 52, 54, 55, 56, 57)	<b>R41</b>	316L stainless steel, Ø 20 mm (for actuators 30, 31, 51, 52, 54, 55, 56, 57)	<b>R36</b>	Steel, with self-lubrication, Ø 16 mm (for actuators 30, 31, 51, 52, 54, 55, 56, 57)	<b>R25</b>	technopolymer, Ø 35 mm (for actuators 30, 31, 51, 52, 54, 55, 56, 57)	<b>R5</b>	rubber, Ø 40 mm (for actuators 30, 31, 51, 52, 54, 55, 56, 57)	<b>R26</b>	rubber, Ø 50 mm (for actuators 51, 52, 54, 55, 56, 57)	<b>R27</b>	rubber, protruding, Ø 50 mm (for actuators 55, 56)
Contact type																																										
	silver contacts (standard)																																									
<b>G</b>	silver contacts, 1 µm gold coating																																									
<b>G1</b>	silver contacts, 2.5 µm gold coating (except contact blocks 2, 20, 21, 22)																																									
Threaded conduit entry																																										
<b>M2</b>	M20x1.5 (standard)																																									
	PG 13.5																																									
Rollers																																										
	standard roller																																									
<b>R28</b>	Steel, with self-lubrication, Ø 12 mm (for actuators A4, 15)																																									
<b>R44</b>	316L stainless steel, Ø 12 mm (for actuators A4, 13, 15)																																									
<b>R23</b>	Steel, with self-lubrication, Ø 14 mm (for actuators A2, 02, A5, 05, 30, 31, 51, 52, 54, 55, 56, 57)																																									
<b>R43</b>	316L stainless steel, Ø 14 mm (for actuators A2, 02, A5, 05, 30, 31, 51, 52, 54, 55, 56, 57)																																									
<b>R24</b>	Steel, with self-lubrication, Ø 20 mm (for actuators 30, 31, 51, 52, 54, 55, 56, 57)																																									
<b>R41</b>	316L stainless steel, Ø 20 mm (for actuators 30, 31, 51, 52, 54, 55, 56, 57)																																									
<b>R36</b>	Steel, with self-lubrication, Ø 16 mm (for actuators 30, 31, 51, 52, 54, 55, 56, 57)																																									
<b>R25</b>	technopolymer, Ø 35 mm (for actuators 30, 31, 51, 52, 54, 55, 56, 57)																																									
<b>R5</b>	rubber, Ø 40 mm (for actuators 30, 31, 51, 52, 54, 55, 56, 57)																																									
<b>R26</b>	rubber, Ø 50 mm (for actuators 51, 52, 54, 55, 56, 57)																																									
<b>R27</b>	rubber, protruding, Ø 50 mm (for actuators 55, 56)																																									



### Main features

- Metal housing, one conduit entry
- Hinged cover, fixed with single captive screw
- Protection degree IP67 and up to IP69K for actuators without external gasket
- 17 contact blocks available
- 43 actuators available
- Versions with M12 connector
- Versions with gold-plated silver contacts

### Quality marks:



IMQ approval:	EG610
UL approval:	E131787
CCC approval:	2021000305000101
EAC approval:	RU C-IT.YT03.B.00035/19

### Technical data

#### Housing

Metal housing, powder-coated	
One threaded conduit entry:	M20x1.5 (standard)
Protection degree with actuators A1, A2, A4, A5, A7, 08, 20, 21, 22, 25:	IP67 acc. to EN 60529 (with cable gland of equal or higher protection degree)
Protection degree with actuators 01, 02, 05, 07, 10, 12, 13, 14, 15, 15-R28, 16, 17, 30, 31, 33, 34, 38, 50, 51, 52, 53, 54, 56, 57, 69, 76:	IP69K acc. to ISO 20653 (with cable gland of equal or higher protection degree)

#### General data

Ambient temperature:	-25°C ... +80°C (standard) -40°C ... +80°C (T6 option)
Max. actuation frequency:	3600 operating cycles/hour
Mechanical endurance:	20 million operating cycles
Mounting position:	any
Safety parameter B <sub>10D</sub> :	40,000,000 for NC contacts
Mechanical interlock, not coded:	type 1 acc. to EN ISO 14119
Tightening torques for installation:	see page 231
Wire cross-sections and wire stripping lengths:	see page 249

#### In compliance with standards:

IEC 60947-5-1, EN 60947-5-1, EN 60947-1, EN 50047, IEC 60204-1, EN 60204-1, EN ISO 14119, EN ISO 12100, IEC 60529, EN 60529, EN IEC 63000, UL 508, CSA C22.2 No. 14.

#### Approvals:

IEC 60947-5-1, UL 508, CSA C22.2 No. 14, GB/T14048.5.

#### Compliance with the requirements of:

Low Voltage Directive 2014/35/EU, EMC Directive 2014/30/EU, RoHS Directive 2011/65/EU.

#### Positive contact opening in conformity with standards:

IEC 60947-5-1, EN 60947-5-1.

### Installation for safety applications:

Use only switches marked with the  $\ominus$  symbol beside the product code. Always connect the safety circuit to the **NC contacts** (normally closed contacts: 11-12, 21-22 or 31-32) as required by **EN ISO 14119, paragraph 5.4** for specific interlock applications and **EN ISO 13849-2 tables D3** (well-tried components) and **D.8** (fault exclusions) for safety applications in general. Actuate the switch **at least up to the positive opening travel** shown in the travel diagrams on page 232. Actuate the switch **at least with the positive opening force**, reported in brackets below each article, next to the actuating force value.

**⚠ If not expressly indicated in this chapter, for correct installation and utilization of all articles see the instructions given on pages 227 to 242.**

	Electrical data	Utilization category
without connector	Thermal current ( $I_{th}$ ):	10 A
	Rated insulation voltage ( $U_r$ ):	500 Vac 600 Vdc 400 Vac 500 Vdc (contact blocks 2, 11, 12, 20, 21, 22)
	Rated impulse withstand voltage ( $U_{imp}$ ):	6 kV 4 kV (contact blocks 20, 21, 22)
	Conditional short circuit current: Protection against short circuits: Pollution degree:	1000 A acc. to EN 60947-5-1 type aM fuse 10 A 500 V 3
with M12 connector, 5-pole	Thermal current ( $I_{th}$ ):	4 A
	Rated insulation voltage ( $U_r$ ):	250 Vac 300 Vdc
	Protection against short circuits: Pollution degree:	type gG fuse 4 A 500 V 3
	Utilization category	Alternating current: AC15 (50÷60 Hz) Ue (V) 250 400 500 Ie (A) 6 4 1 Direct current: DC13 Ue (V) 24 125 250 Ie (A) 3 0.55 0.3
with M12 connector, 8-pole	Thermal current ( $I_{th}$ ):	2 A
	Rated insulation voltage ( $U_r$ ):	30 Vac 36 Vdc
	Protection against short circuits: Pollution degree:	type gG fuse 2 A 500 V 3
	Utilization category	Alternating current: AC15 (50÷60 Hz) Ue (V) 24 Ie (A) 2 Direct current: DC13 Ue (V) 24 Ie (A) 2



### Features approved by IMQ

Rated insulation voltage (U<sub>i</sub>): 500 Vac  
 400 Vac (for contact blocks 2, 11, 12, 20, 21, 22, 28, 29, 30, 37, 33, 34)

Conventional free air thermal current (I<sub>th</sub>): 10 A

Protection against short circuits: type aM fuse 10 A 500 V

Rated impulse withstand voltage (U<sub>imp</sub>): 6 kV

4 kV (for contact blocks 20, 21, 22, 28, 29, 30, 33, 34)

Protection degree of the housing: IP67

MV terminals (screw terminals): 3

Pollution degree: AC15

Utilization category: 400 Vac (50 Hz)

Operating voltage (U<sub>e</sub>): 3 A

Operating current (I<sub>e</sub>):

Forms of the contact element: Za, Za+Za, X+X, Zb, Y+Y, Y+Y+X, Y+Y+Y, Y+X+X, Y, X.

Positive opening of contacts on contact blocks 5, 6, 7, 8, 9, 11, 13, 14, 16, 17, 18, 19, 20, 21, 22, 28, 29, 30, 33, 34, 37, 38, 39, 66.

In compliance with standards: EN 60947-1, EN 60947-5-1, fundamental requirements of the Low Voltage Directive 2014/35/EU.

Please contact our technical department for the list of approved products.

### Features approved by UL

Electrical Ratings: Q300 pilot duty (69 VA, 125-250 V dc)  
 A600 pilot duty (720 VA, 120-600 V ac)

Environmental Ratings: Types 1, 4X, 12, 13

For all contact blocks except 2 and 3 use 60 or 75°C copper (Cu) conductors, rigid or flexible, wire size 12, 14 AWG. Tightening torque for terminal screws of 7.1 lb in (0.8 Nm).

For contact blocks 2 and 3 use 60 or 75°C copper (Cu) conductors, rigid or flexible, wire size 14 AWG. Tightening torque for terminal screws of 12 lb in (1.4 Nm).

Please contact our technical department for the list of approved products.

### Wiring diagram for M12 connectors

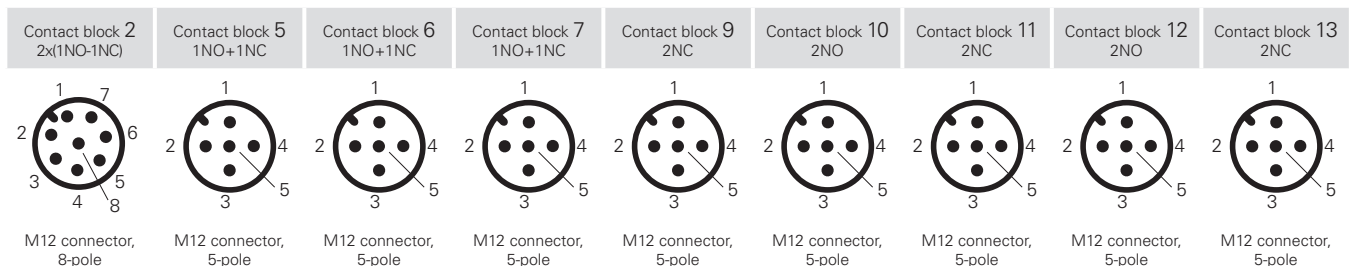

Contacts	Pin no.	Contacts	Pin no.	Contacts	Pin no.	Contacts	Pin no.	Contacts	Pin no.	Contacts	Pin no.	Contacts	Pin no.	Contacts	Pin no.	Contacts	Pin no.	Contacts	Pin no.		
NO	3-4	NC	1-2	NC	1-2	NC	1-2	NC	1-2	NO	1-2	NC	1-2	NO	1-2	NC	1-2	NO	1-2	NC (1°)	1-2
NC	5-6	NO	3-4	NO	3-4	NO	3-4	NC	3-4	NO	3-4	NC	3-4	NO	3-4	NO	3-4	NO	3-4	NC (2°)	3-4
NC	7-8	ground	5	ground	5	ground	5	ground	5	ground	5	ground	5	ground	5	ground	5	ground	5	ground	5
NO	1-2																				

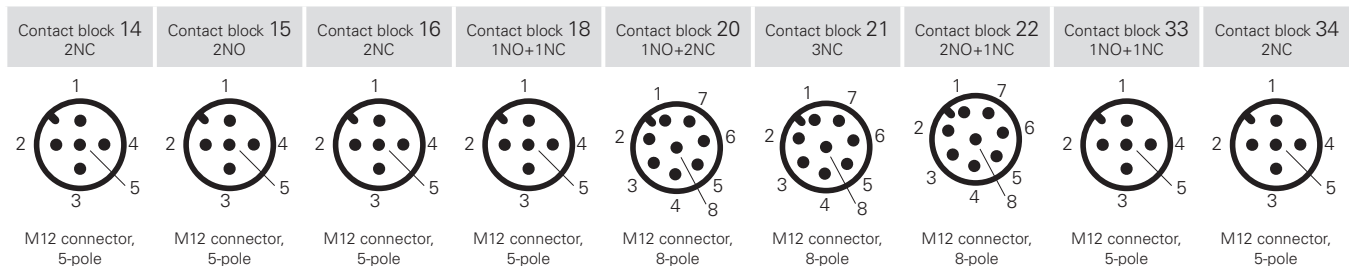

Contacts	Pin no.	Contacts	Pin no.	Contacts	Pin no.	Contacts	Pin no.	Contacts	Pin no.	Contacts	Pin no.	Contacts	Pin no.	Contacts	Pin no.	Contacts	Pin no.	Contacts	Pin no.	Contacts	Pin no.
NC (1°)	1-2	NO (1°)	1-2	NC, lever to the right	1-2	NC	1-2	NC	3-4	NC	3-4	NC	3-4	NC	3-4	NC	1-2	NC	1-2	NC	1-2
NC (2°)	3-4	NO (2°)	3-4	NC, lever to the left	3-4	NO	3-4	NC	5-6	NC	5-6	NO	5-6	NO	5-6	NO	3-4	NO	3-4	NC	3-4
ground	5	ground	5	ground	5	ground	5	NO	7-8	NC	7-8	NO	7-8	ground	5	ground	5	ground	5	ground	5
								ground	1	ground	1	ground	1								

Contact block E1  
PNP

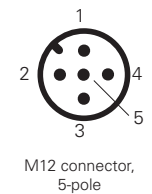

Contacts	Pin no.
+	1
-	3
NC	2
NO	4
ground	5

# FM series position switches

- R** = snap action  
**L** = slow action  
**LO** = slow action, make before break  
**LS** = slow action, shifted  
**LV** = slow action, shifted and spaced  
**LI** = slow action, independent  
**LA** = slow action, close  
**⏏** = electronic, PNP

Contact block

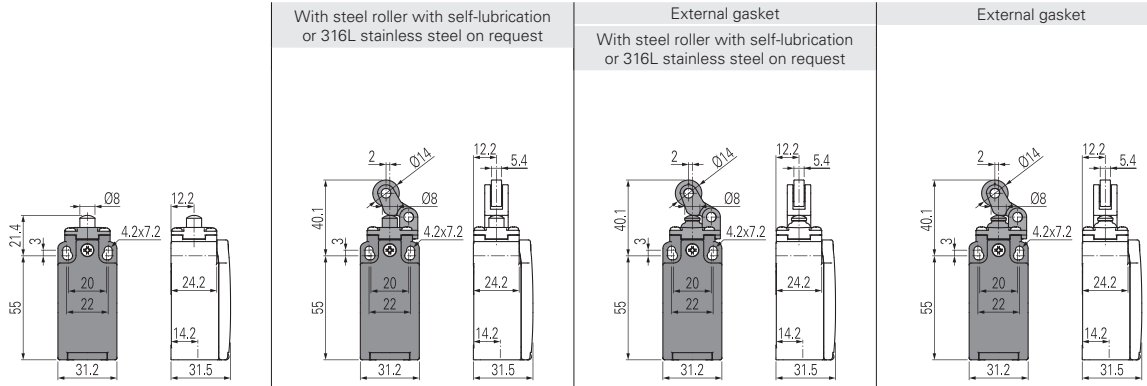

	With steel roller with self-lubrication or 316L stainless steel on request	External gasket	External gasket	External gasket
2 <b>R</b>	FM 201-M2 2x(1NO-1NC)	FM 202-M2 2x(1NO-1NC)	FM 2A2-M2 2x(1NO-1NC)	FM 2A4-M2 2x(1NO-1NC)
5 <b>R</b>	FM 501-M2 ⊕ 1NO+1NC	FM 502-M2 ⊕ 1NO+1NC	FM 5A2-M2 ⊕ 1NO+1NC	FM 5A4-M2 ⊕ 1NO+1NC
6 <b>L</b>	FM 601-M2 ⊕ 1NO+1NC	FM 602-M2 ⊕ 1NO+1NC	FM 6A2-M2 ⊕ 1NO+1NC	FM 6A4-M2 ⊕ 1NO+1NC
7 <b>LO</b>	FM 701-M2 ⊕ 1NO+1NC	FM 702-M2 ⊕ 1NO+1NC	FM 7A2-M2 ⊕ 1NO+1NC	FM 7A4-M2 ⊕ 1NO+1NC
9 <b>L</b>	FM 901-M2 ⊕ 2NC	FM 902-M2 ⊕ 2NC	FM 9A2-M2 ⊕ 2NC	FM 9A4-M2 ⊕ 2NC
10 <b>L</b>	FM 1001-M2 2NO	FM 1002-M2 2NO	FM 10A2-M2 2NO	FM 10A4-M2 2NO
11 <b>R</b>	FM 1101-M2 ⊕ 2NC	FM 1102-M2 ⊕ 2NC	FM 11A2-M2 ⊕ 2NC	FM 11A4-M2 ⊕ 2NC
12 <b>R</b>	FM 1201-M2 2NO	FM 1202-M2 2NO	FM 12A2-M2 2NO	FM 12A4-M2 2NO
13 <b>LV</b>	FM 1301-M2 ⊕ 2NC	FM 1302-M2 ⊕ 2NC	FM 13A2-M2 ⊕ 2NC	FM 13A4-M2 ⊕ 2NC
14 <b>LS</b>	FM 1401-M2 ⊕ 2NC	FM 1402-M2 ⊕ 2NC	FM 14A2-M2 ⊕ 2NC	FM 14A4-M2 ⊕ 2NC
15 <b>LS</b>	FM 1501-M2 2NO	FM 1502-M2 2NO	FM 15A2-M2 2NO	FM 15A4-M2 2NO
18 <b>LA</b>	FM 1801-M2 ⊕ 1NO+1NC	FM 1802-M2 ⊕ 1NO+1NC	FM 18A2-M2 ⊕ 1NO+1NC	FM 18A4-M2 ⊕ 1NO+1NC
20 <b>L</b>	FM 2001-M2 ⊕ 1NO+2NC	FM 2002-M2 ⊕ 1NO+2NC	FM 20A2-M2 ⊕ 1NO+2NC	FM 20A4-M2 ⊕ 1NO+2NC
21 <b>L</b>	FM 2101-M2 ⊕ 3NC	FM 2102-M2 ⊕ 3NC	FM 21A2-M2 ⊕ 3NC	FM 21A4-M2 ⊕ 3NC
22 <b>L</b>	FM 2201-M2 ⊕ 2NO+1NC	FM 2202-M2 ⊕ 2NO+1NC	FM 22A2-M2 ⊕ 2NO+1NC	FM 22A4-M2 ⊕ 2NO+1NC
E1 <b>⏏</b>	FM E101-M2 1NO-1NC	FM E102-M2 1NO-1NC	FM E1A2-M2 1NO-1NC	FM E1A4-M2 1NO-1NC
Max. speed	page 231 - type 4	page 231 - type 3	page 231 - type 3	page 231 - type 5
Actuating force	8 N (25 N ⊕)	6 N (25 N ⊕)	4.3 N (25 N ⊕)	4.3 N (25 N ⊕)
Travel diagrams	page 232 - group 1	page 232 - group 2	page 232 - group 2	page 232 - group 1

- R** = snap action  
**L** = slow action  
**LO** = slow action, make before break  
**LS** = slow action, shifted  
**LV** = slow action, shifted and spaced  
**LI** = slow action, independent  
**LA** = slow action, close  
**⏏** = electronic, PNP

Contact block

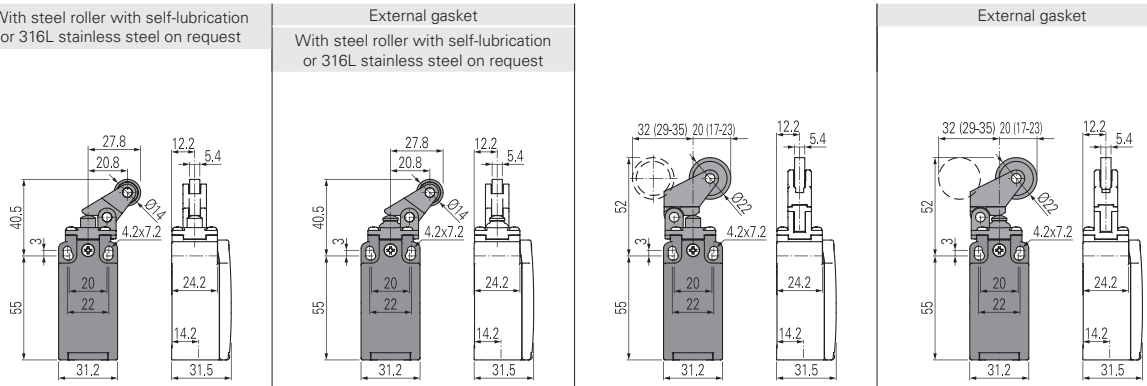

	With steel roller with self-lubrication or 316L stainless steel on request	External gasket	External gasket	External gasket
2 <b>R</b>	FM 205-M2 2x(1NO-1NC)	FM 2A5-M2 2x(1NO-1NC)	FM 207-M2 2x(1NO-1NC)	FM 2A7-M2 2x(1NO-1NC)
5 <b>R</b>	FM 505-M2 ⊕ 1NO+1NC	FM 5A5-M2 ⊕ 1NO+1NC	FM 507-M2 ⊕ 1NO+1NC	FM 5A7-M2 ⊕ 1NO+1NC
6 <b>L</b>	FM 605-M2 ⊕ 1NO+1NC	FM 6A5-M2 ⊕ 1NO+1NC	FM 607-M2 ⊕ 1NO+1NC	FM 6A7-M2 ⊕ 1NO+1NC
7 <b>LO</b>	FM 705-M2 ⊕ 1NO+1NC	FM 7A5-M2 ⊕ 1NO+1NC	FM 707-M2 ⊕ 1NO+1NC	FM 7A7-M2 ⊕ 1NO+1NC
9 <b>L</b>	FM 905-M2 ⊕ 2NC	FM 9A5-M2 ⊕ 2NC	FM 907-M2 ⊕ 2NC	FM 9A7-M2 ⊕ 2NC
10 <b>L</b>	FM 1005-M2 2NO	FM 10A5-M2 2NO	FM 1007-M2 2NO	FM 10A7-M2 2NO
11 <b>R</b>	FM 1105-M2 ⊕ 2NC	FM 11A5-M2 ⊕ 2NC	FM 1107-M2 ⊕ 2NC	FM 11A7-M2 ⊕ 2NC
12 <b>R</b>	FM 1205-M2 2NO	FM 12A5-M2 2NO	FM 1207-M2 2NO	FM 12A7-M2 2NO
13 <b>LV</b>	FM 1305-M2 ⊕ 2NC	FM 13A5-M2 ⊕ 2NC	FM 1307-M2 ⊕ 2NC	FM 13A7-M2 ⊕ 2NC
14 <b>LS</b>	FM 1405-M2 ⊕ 2NC	FM 14A5-M2 ⊕ 2NC	FM 1407-M2 ⊕ 2NC	FM 14A7-M2 ⊕ 2NC
15 <b>LS</b>	FM 1505-M2 2NO	FM 15A5-M2 2NO	FM 1507-M2 2NO	FM 15A7-M2 2NO
18 <b>LA</b>	FM 1805-M2 ⊕ 1NO+1NC	FM 18A5-M2 ⊕ 1NO+1NC	FM 1807-M2 ⊕ 1NO+1NC	FM 18A7-M2 ⊕ 1NO+1NC
20 <b>L</b>	FM 2005-M2 ⊕ 1NO+2NC	FM 20A5-M2 ⊕ 1NO+2NC	FM 2007-M2 ⊕ 1NO+2NC	FM 20A7-M2 ⊕ 1NO+2NC
21 <b>L</b>	FM 2105-M2 ⊕ 3NC	FM 21A5-M2 ⊕ 3NC	FM 2107-M2 ⊕ 3NC	FM 21A7-M2 ⊕ 3NC
22 <b>L</b>	FM 2205-M2 ⊕ 2NO+1NC	FM 22A5-M2 ⊕ 2NO+1NC	FM 2207-M2 ⊕ 2NO+1NC	FM 22A7-M2 ⊕ 2NO+1NC
E1 <b>⏏</b>	FM E105-M2 1NO-1NC	FM E1A5-M2 1NO-1NC	FM E107-M2 1NO-1NC	FM E1A7-M2 1NO-1NC
Max. speed	page 231 - type 3	page 231 - type 3	page 231 - type 3	page 231 - type 3
Actuating force	6 N (25 N ⊕)	4.3 N (25 N ⊕)	4 N (25 N ⊕)	3 N (25 N ⊕)
Travel diagrams	page 232 - group 2	page 232 - group 2	page 232 - group 3	page 232 - group 3

All values in the drawings are in mm

Accessories See page 207

→ The 2D and 3D files are available at [www.pizzato.com](http://www.pizzato.com)





Contact type	External gasket			
<b>R</b> = snap action <b>L</b> = slow action <b>LO</b> = slow action, make before break <b>LS</b> = slow action, shifted <b>LV</b> = slow action, shifted and spaced <b>LI</b> = slow action, independent <b>LA</b> = slow action, close <b>⌘</b> = electronic, PNP				
Max. speed	page 231 - type 4		page 231 - type 2	
Actuating force	8 N (25 N $\ominus$ )		8 N (25 N $\ominus$ )	
Travel diagrams	page 232 - group 1		page 232 - group 1	

Contact type	External gasket		External gasket	
<b>R</b> = snap action <b>L</b> = slow action <b>LO</b> = slow action, make before break <b>LS</b> = slow action, shifted <b>LV</b> = slow action, shifted and spaced <b>LI</b> = slow action, independent <b>LA</b> = slow action, close <b>⌘</b> = electronic, PNP				
Max. speed	page 231 - type 2		1 m/s	1 m/s
Actuating force	8 N (25 N $\ominus$ )		0.07 Nm	0.07 Nm
Travel diagrams	page 232 - group 1		page 232 - group 4	page 232 - group 4

All values in the drawings are in mm





Accessories See page 207

➔ The 2D and 3D files are available at [www.pizzato.com](http://www.pizzato.com)

# FM series position switches

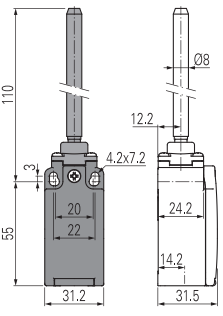
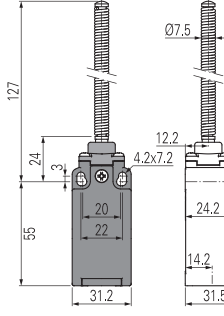
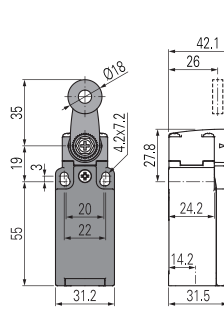
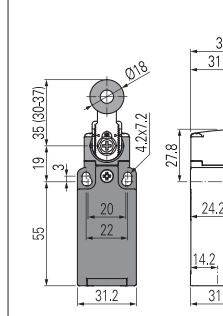

- R** = snap action  
**L** = slow action  
**LO** = slow action, make before break  
**LS** = slow action, shifted  
**LV** = slow action, shifted and spaced  
**LI** = slow action, independent  
**LA** = slow action, close  
 = electronic, PNP

Contact block

	External gasket Rigid rod		External gasket Spring rod		With Ø 20 mm steel roller with self-lubrication or 316L stainless steel on request	Other rollers available. See page 78		
								
2	<b>R</b> FM 222-M2	2x(1NO-1NC)	FM 225-M2	2x(1NO-1NC)	FM 230-M2	2x(1NO-1NC)	FM 231-M2	2x(1NO-1NC)
5	<b>R</b> /	/	FM 525-M2	1NO+1NC	FM 530-M2	1NO+1NC	FM 531-M2	1NO+1NC
6	<b>L</b> /	/	/	/	FM 630-M2	1NO+1NC	FM 631-M2	1NO+1NC
7	<b>LO</b> /	/	/	/	FM 730-M2	1NO+1NC	FM 731-M2	1NO+1NC
9	<b>L</b> /	/	/	/	FM 930-M2	2NC	FM 931-M2	2NC
10	<b>L</b> FM 1022-M2	2NO	FM 1025-M2	2NO	FM 1030-M2	2NO	FM 1031-M2	2NO
11	<b>R</b> /	/	/	/	FM 1130-M2	2NC	FM 1131-M2	2NC
12	<b>R</b> FM 1222-M2	2NO	FM 1225-M2	2NO	FM 1230-M2	2NO	FM 1231-M2	2NO
13	<b>LV</b> /	/	/	/	FM 1330-M2	2NC	FM 1331-M2	2NC
14	<b>LS</b> /	/	/	/	FM 1430-M2	2NC	FM 1431-M2	2NC
15	<b>LS</b> /	/	/	/	FM 1530-M2	2NO	FM 1531-M2	2NO
16	<b>LI</b> /	/	/	/	FM 1630-M2	2NC	FM 1631-M2	2NC
18	<b>LA</b> FM 1822-M2	1NO+1NC	FM 1825-M2	1NO+1NC	FM 1830-M2	1NO+1NC	FM 1831-M2	1NO+1NC
20	<b>L</b> FM 2022-M2	1NO+2NC	FM 2025-M2	1NO+2NC	FM 2030-M2	1NO+2NC	FM 2031-M2	1NO+2NC
21	<b>L</b> FM 2122-M2	3NC	FM 2125-M2	3NC	FM 2130-M2	3NC	FM 2131-M2	3NC
22	<b>L</b> FM 2222-M2	2NO+1NC	FM 2225-M2	2NO+1NC	FM 2230-M2	2NO+1NC	FM 2231-M2	2NO+1NC
E1	 FM E122-M2	1NO-1NC	FM E125-M2	1NO-1NC	FM E130-M2	1NO-1NC	FM E131-M2	1NO-1NC
Max. speed	1 m/s		1 m/s		page 231 - type 1		page 231 - type 1	
Actuating force	0.12 Nm (0.25 Nm  )		0.12 Nm		0.06 Nm (0.25 Nm  )		0.06 Nm (0.25 Nm  )	
Travel diagrams	page 232 - group 4		page 232 - group 4		page 232 - group 5		page 232 - group 5	

- R** = snap action  
**L** = slow action  
**LO** = slow action, make before break  
**LS** = slow action, shifted  
**LV** = slow action, shifted and spaced  
**LI** = slow action, independent  
**LA** = slow action, close  
 = electronic, PNP

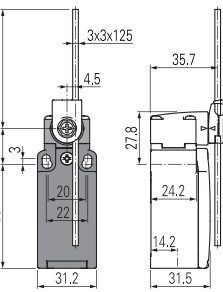
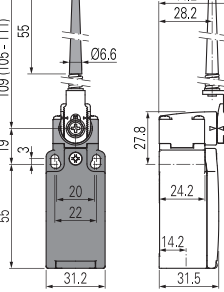
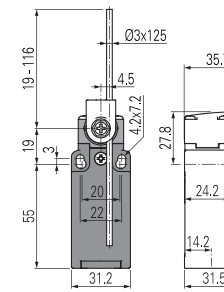
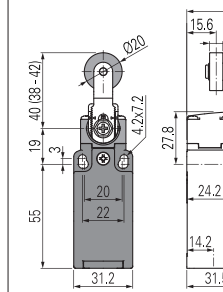
Contact block

	Square rod, 3x3 mm		Spring rod		Round rod, Ø 3 mm, stainless steel	Other rollers available. See page 78		
								
2	<b>R</b> FM 233-M2	2x(1NO-1NC)	FM 234-M2	2x(1NO-1NC)	FM 250-M2	2x(1NO-1NC)	FM 251-M2	2x(1NO-1NC)
5	<b>R</b> FM 533-M2	1NO+1NC	FM 534-M2	1NO+1NC	FM 550-M2	1NO+1NC	FM 551-M2	1NO+1NC
6	<b>L</b> FM 633-M2	1NO+1NC	FM 634-M2	1NO+1NC	FM 650-M2	1NO+1NC	FM 651-M2	1NO+1NC
7	<b>LO</b> FM 733-M2	1NO+1NC	FM 734-M2	1NO+1NC	FM 750-M2	1NO+1NC	FM 751-M2	1NO+1NC
9	<b>L</b> FM 933-M2	2NC	FM 934-M2	2NC	FM 950-M2	2NC	FM 951-M2	2NC
10	<b>L</b> FM 1033-M2	2NO	FM 1034-M2	2NO	FM 1050-M2	2NO	FM 1051-M2	2NO
11	<b>R</b> FM 1133-M2	2NC	FM 1134-M2	2NC	FM 1150-M2	2NC	FM 1151-M2	2NC
12	<b>R</b> FM 1233-M2	2NO	FM 1234-M2	2NO	FM 1250-M2	2NO	FM 1251-M2	2NO
13	<b>LV</b> FM 1333-M2	2NC	FM 1343-M2	2NC	FM 1350-M2	2NC	FM 1351-M2	2NC
14	<b>LS</b> FM 1433-M2	2NC	FM 1434-M2	2NC	FM 1450-M2	2NC	FM 1451-M2	2NC
15	<b>LS</b> FM 1533-M2	2NO	FM 1534-M2	2NO	FM 1550-M2	2NO	FM 1551-M2	2NO
16	<b>LI</b> FM 1633-M2	2NC	FM 1634-M2	2NC	FM 1650-M2	2NC	FM 1651-M2	2NC
18	<b>LA</b> FM 1833-M2	1NO+1NC	FM 1834-M2	1NO+1NC	FM 1850-M2	1NO+1NC	FM 1851-M2	1NO+1NC
20	<b>L</b> FM 2033-M2	1NO+2NC	FM 2034-M2	1NO+2NC	FM 2050-M2	1NO+2NC	FM 2051-M2	1NO+2NC
21	<b>L</b> FM 2133-M2	3NC	FM 2134-M2	3NC	FM 2150-M2	3NC	FM 2151-M2	3NC
22	<b>L</b> FM 2233-M2	2NO+1NC	FM 2234-M2	2NO+1NC	FM 2250-M2	2NO+1NC	FM 2251-M2	2NO+1NC
E1	 FM E133-M2	1NO-1NC	FM E134-M2	1NO-1NC	FM E150-M2	1NO-1NC	FM E151-M2	1NO-1NC
Max. speed	1.5 m/s		1.5 m/s		1.5 m/s		page 231 - type 1	
Actuating force	0.06 Nm		0.06 Nm		0.06 Nm		0.06 Nm (0.25 Nm  )	
Travel diagrams	page 232 - group 5		page 232 - group 5		page 232 - group 5		page 232 - group 5	

All values in the drawings are in mm

Accessories See page 207

The 2D and 3D files are available at [www.pizzato.com](http://www.pizzato.com)



- Contact type
- R** = snap action
  - L** = slow action
  - LO** = slow action, make before break
  - LS** = slow action, shifted
  - LV** = slow action, shifted and spaced
  - LI** = slow action, independent
  - LA** = slow action, close
  - ⏏** = electronic, PNP

Contact block

	Other rollers available. See page 78	Porcelain roller	Other rollers available. See page 78	Other rollers available. See page 78
2	<b>R</b> FM 252-M2 2x(1NO-1NC)	FM 253-E0M2 2x(1NO-1NC)	FM 254-M2 2x(1NO-1NC)	FM 256-M2 2x(1NO-1NC)
5	<b>R</b> FM 552-M2 ⊕ 1NO+1NC	FM 553-E0M2V9 ⊕ 1NO+1NC	FM 554-M2 ⊕ 1NO+1NC	FM 556-M2 ⊕ 1NO+1NC
6	<b>L</b> FM 652-M2 ⊕ 1NO+1NC	FM 653-E0M2V9 ⊕ 1NO+1NC	FM 654-M2 ⊕ 1NO+1NC	FM 656-M2 ⊕ 1NO+1NC
7	<b>LO</b> FM 752-M2 ⊕ 1NO+1NC	FM 753-E0M2V9 ⊕ 1NO+1NC	FM 754-M2 ⊕ 1NO+1NC	FM 756-M2 ⊕ 1NO+1NC
9	<b>L</b> FM 952-M2 ⊕ 2NC	FM 953-E0M2V9 ⊕ 2NC	FM 954-M2 ⊕ 2NC	FM 956-M2 ⊕ 2NC
10	<b>L</b> FM 1052-M2 2NO	FM 1053-E0M2V9 2NO	FM 1054-M2 2NO	FM 1056-M2 2NO
11	<b>R</b> FM 1152-M2 ⊕ 2NC	/	FM 1154-M2 ⊕ 2NC	FM 1156-M2 ⊕ 2NC
12	<b>R</b> FM 1252-M2 2NO	FM 1253-E0M2V9 2NO	FM 1254-M2 2NO	FM 1256-M2 2NO
13	<b>LV</b> FM 1352-M2 ⊕ 2NC	FM 1353-E0M2V9 ⊕ 2NC	FM 1354-M2 ⊕ 2NC	FM 1356-M2 ⊕ 2NC
14	<b>LS</b> FM 1452-M2 ⊕ 2NC	FM 1453-E0M2V9 ⊕ 2NC	FM 1454-M2 ⊕ 2NC	FM 1456-M2 ⊕ 2NC
15	<b>LS</b> FM 1552-M2 2NO	FM 1553-E0M2V9 2NO	FM 1554-M2 2NO	FM 1556-M2 2NO
16	<b>LI</b> FM 1652-M2 ⊕ 2NC	/	FM 1654-M2 ⊕ 2NC	FM 1656-M2 ⊕ 2NC
18	<b>LA</b> FM 1852-M2 ⊕ 1NO+1NC	FM 1853-E0M2V9 ⊕ 1NO+1NC	FM 1854-M2 ⊕ 1NO+1NC	FM 1856-M2 ⊕ 1NO+1NC
20	<b>L</b> FM 2052-M2 ⊕ 1NO+2NC	FM 2053-E0M2V9 ⊕ 1NO+2NC	FM 2054-M2 ⊕ 1NO+2NC	FM 2056-M2 ⊕ 1NO+2NC
21	<b>L</b> FM 2152-M2 ⊕ 3NC	FM 2153-E0M2V9 ⊕ 3NC	FM 2154-M2 ⊕ 3NC	FM 2156-M2 ⊕ 3NC
22	<b>L</b> FM 2252-M2 ⊕ 2NO+1NC	FM 2253-E0M2V9 ⊕ 2NO+1NC	FM 2254-M2 ⊕ 2NO+1NC	FM 2256-M2 ⊕ 2NO+1NC
E1	<b>⏏</b> FM E152-M2 1NO-1NC	FM E153-E0M2V9 1NO-1NC	FM E154-M2 1NO-1NC	FM E156-M2 1NO-1NC
Max. speed	page 231 - type 1	0.5 m/s	page 231 - type 1	page 231 - type 1
Actuating force	0.06 Nm (0.25 Nm ⊕)	0.03 Nm (0.25 Nm ⊕)	0.06 Nm (0.25 Nm ⊕)	0.06 Nm (0.25 Nm ⊕)
Travel diagrams	page 232 - group 5	page 232 - group 6	page 232 - group 5	page 232 - group 5

- Contact type
- R** = snap action
  - L** = slow action
  - LO** = slow action, make before break
  - LS** = slow action, shifted
  - LV** = slow action, shifted and spaced
  - LI** = slow action, independent
  - LA** = slow action, close
  - ⏏** = electronic, PNP

Contact block

	Other rollers available. See page 78	Glass fibre rod	Rope switch for signalling
2	<b>R</b> FM 257-M2 2x(1NO-1NC)	FM 269-M2 2x(1NO-1NC)	FM 276-M2 2x(1NO-1NC)
5	<b>R</b> FM 557-M2 ⊕ 1NO+1NC	FM 569-M2 1NO+1NC	FM 576-M2 1NO+1NC
6	<b>L</b> FM 657-M2 ⊕ 1NO+1NC	FM 669-M2 1NO+1NC	FM 676-M2 1NO+1NC
7	<b>LO</b> FM 757-M2 ⊕ 1NO+1NC	FM 769-M2 1NO+1NC	FM 776-M2 1NO+1NC
9	<b>L</b> FM 957-M2 ⊕ 2NC	FM 969-M2 2NC	FM 976-M2 2NO
10	<b>L</b> FM 1057-M2 2NO	FM 1069-M2 2NO	FM 1076-M2 2NC
11	<b>R</b> FM 1157-M2 ⊕ 2NC	FM 1169-M2 2NC	FM 1176-M2 2NO
12	<b>R</b> FM 1257-M2 2NO	FM 1269-M2 2NO	FM 1276-M2 2NC
13	<b>LV</b> FM 1357-M2 ⊕ 2NC	FM 1369-M2 2NC	FM 1376-M2 2NO
14	<b>LS</b> FM 1457-M2 ⊕ 2NC	FM 1469-M2 2NC	FM 1476-M2 2NO
15	<b>LS</b> FM 1557-M2 2NO	FM 1569-M2 2NO	FM 1576-M2 2NC
16	<b>LI</b> FM 1657-M2 ⊕ 2NC	FM 1669-M2 2NC	/
18	<b>LA</b> FM 1857-M2 ⊕ 1NO+1NC	FM 1869-M2 1NO+1NC	FM 1876-M2 1NO+1NC
20	<b>L</b> FM 2057-M2 ⊕ 1NO+2NC	FM 2069-M2 1NO+2NC	FM 2076-M2 2NO+1NC
21	<b>L</b> FM 2157-M2 ⊕ 3NC	FM 2169-M2 3NC	FM 2176-M2 3NO
22	<b>L</b> FM 2257-M2 ⊕ 2NO+1NC	FM 2269-M2 2NO+1NC	FM 2276-M2 1NO+2NC
E1	<b>⏏</b> FM E157-M2 1NO-1NC	FM E169-M2 1NO-1NC	/
Max. speed	page 231 - type 1	1.5 m/s	0.5 m/s
Actuating force	0.06 N (0.25 N ⊕)	0.06 Nm	initial 20 N - final 40 N
Travel diagrams	page 232 - group 5	page 232 - group 5	page 232 - group 7

(1) Positive opening only with actuator set to max. See page 78.  
All values in the drawings are in mm

## FM series position switches with reset



The majority of switches can be equipped with a reset device (option W3) which enables the simultaneous actuation of actuator and contact block. The device is a module that is mounted between the body and the head of the switch that can be rotated independently from the head. The reset device has the following advantages:

- can be integrated into the majority of standard actuator heads;
- contact blocks with snap action are no more necessary because the tripping movement is executed by the reset device itself;
- can be rotated independently from the head ensuring maximum flexibility during installation;
- can be delivered with two different actuating forces: standard and increased for vibration applications;
- mechanical endurance: 1 million operating cycles.

Contact type		With steel roller with self-lubrication or 316L stainless steel on request		With steel roller with self-lubrication or 316L stainless steel on request		With steel roller with self-lubrication or 316L stainless steel on request			
R = snap action L = slow action									
Contact block									
2	R	FM 201-W3M2	2x(1NO-1NC)	FM 202-W3M2	2x(1NO-1NC)	FM 205-W3M2	2x(1NO-1NC)	FM 207-W3M2	2x(1NO-1NC)
6	L	FM 601-W3M2	1NO+1NC	FM 602-W3M2	1NO+1NC	FM 605-W3M2	1NO+1NC	FM 607-W3M2	1NO+1NC
9	L	FM 901-W3M2	2NC	FM 902-W3M2	2NC	FM 905-W3M2	2NC	FM 907-W3M2	2NC
10	L	FM 1001-W3M2	2NO	FM 1002-W3M2	2NO	FM 1005-W3M2	2NO	FM 1007-W3M2	2NO
20	L	FM 2001-W3M2	1NO+2NC	FM 2002-W3M2	1NO+2NC	FM 2005-W3M2	1NO+2NC	FM 2007-W3M2	1NO+2NC
21	L	FM 2101-W3M2	3NC	FM 2102-W3M2	3NC	FM 2105-W3M2	3NC	FM 2107-W3M2	3NC
22	L	FM 2201-W3M2	2NO+1NC	FM 2202-W3M2	2NO+1NC	FM 2205-W3M2	2NO+1NC	FM 2207-W3M2	2NO+1NC
Max. speed		page 231 - type 4		page 231 - type 3		page 231 - type 3		page 231 - type 3	
Actuating force		4.5 N (25 N ⊕)		4 N (25 N ⊕)		4 N (25 N ⊕)		2.5 N (25 N ⊕)	
Travel diagrams		page 231 - group 1		page 231 - group 2		page 231 - group 2		page 231 - group 3	

Contact type		With Ø 20 mm steel roller with self-lubrication or 316L stainless steel on request		Other rollers available. See page 78		Other rollers available. See page 78			
R = snap action L = slow action									
Contact block									
2	R	FM 215-W3M2R28	2x(1NO-1NC)	FM 230-W3M2	2x(1NO-1NC)	FM 231-W3M2	2x(1NO-1NC)	FM 251-W3M2	2x(1NO-1NC)
6	L	FM 615-W3M2R28	1NO+1NC	FM 630-W3M2	1NO+1NC	FM 631-W3M2	1NO+1NC	FM 651-W3M2	1NO+1NC
9	L	FM 915-W3M2R28	2NC	FM 930-W3M2	2NC	FM 931-W3M2	2NC	FM 951-W3M2	2NC
10	L	FM 1015-W3M2R28	2NO	FM 1030-W3M2	2NO	FM 1031-W3M2	2NO	FM 1051-W3M2	2NO
20	L	FM 2015-W3M2R28	1NO+2NC	FM 2030-W3M2	1NO+2NC	FM 2031-W3M2	1NO+2NC	FM 2051-W3M2	1NO+2NC
21	L	FM 2115-W3M2R28	3NC	FM 2130-W3M2	3NC	FM 2131-W3M2	3NC	FM 2151-W3M2	3NC
22	L	FM 2215-W3M2R28	2NO+1NC	FM 2230-W3M2	2NO+1NC	FM 2231-W3M2	2NO+1NC	FM 2251-W3M2	2NO+1NC
Max. speed		page 231 - type 2		page 231 - type 1		page 231 - type 1		page 231 - type 1	
Actuating force		4.5 N (25 N ⊕)		0.07 Nm (0.25 Nm ⊕)		0.07 Nm (0.25 Nm ⊕)		0.07 Nm (0.25 Nm ⊕)	
Travel diagrams		page 231 - group 1		page 231 - group 4		page 231 - group 4		page 231 - group 4	

All values in the drawings are in mm

Accessories See page 207

→ The 2D and 3D files are available at [www.pizzato.com](http://www.pizzato.com)

		Other rollers available. See page 78		Other rollers available. See page 78		Other rollers available. See page 78		Other rollers available. See page 78	
Contact type									
<b>R</b> = snap action <b>L</b> = slow action									
Contact block									
2	<b>R</b>	FM 252-W3M2	2x(1NO-1NC)	FM 254-W3M2	2x(1NO-1NC)	FM 256-W3M2	2x(1NO-1NC)	FM 257-W3M2	2x(1NO-1NC)
6	<b>L</b>	FM 652-W3M2	1NO+1NC	FM 654-W3M2	1NO+1NC	FM 656-W3M2	1NO+1NC	FM 657-W3M2	1NO+1NC
9	<b>L</b>	FM 952-W3M2	2NC	FM 954-W3M2	2NC	FM 956-W3M2	2NC	FM 957-W3M2	2NC
10	<b>L</b>	FM 1052-W3M2	2NO	FM 1054-W3M2	2NO	FM 1056-W3M2	2NO	FM 1057-W3M2	2NO
20	<b>L</b>	FM 2052-W3M2	1NO+2NC	FM 2054-W3M2	1NO+2NC	FM 2056-W3M2	1NO+2NC	FM 2057-W3M2	1NO+2NC
21	<b>L</b>	FM 2152-W3M2	3NC	FM 2154-W3M2	3NC	FM 2156-W3M2	3NC	FM 2157-W3M2	3NC
22	<b>L</b>	FM 2252-W3M2	2NO+1NC	FM 2254-W3M2	2NO+1NC	FM 2256-W3M2	2NO+1NC	FM 2257-W3M2	2NO+1NC
Max. speed		page 231 - type 1		page 231 - type 1		page 231 - type 1		page 231 - type 1	
Actuating force		0.07 Nm (0.25 Nm $\rightarrow$ )		0.07 Nm (0.25 Nm $\rightarrow$ )		0.07 Nm (0.25 Nm $\rightarrow$ )		0.07 Nm (0.25 Nm $\rightarrow$ )	
Travel diagrams		page 231 - group 4		page 231 - group 4		page 231 - group 4		page 231 - group 4	

### Increased actuating force

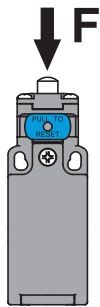

The switch can be delivered with increased actuating force (option W4). Ideal for vibration applications.

Actuators	Actuating force
01, 14, 15, 16	7 N
02, 05	6 N
07	3.5 N
30 ... 57	0.08 Nm

To order the switch with reset and increased actuating force, replace the -W3 option with -W4 in the order code.

Example: FM 601-**W3**M2  $\rightarrow$  FM 601-**W4**M2

## Position switches with swivelling lever without actuator

- Contact type
- R** = snap action
  - L** = slow action
  - LO** = slow action, make before break
  - LS** = slow action, shifted
  - LV** = slow action, shifted and spaced
  - LI** = slow action, independent
  - LA** = slow action, close
  - LA** = electronic, PNP
- Contact block

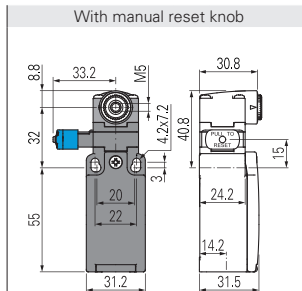
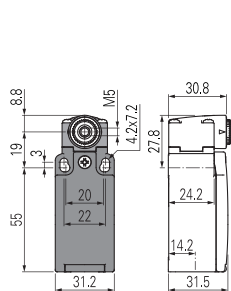

### IMPORTANT

**For safety applications:** join only switches and actuators marked with symbol next to the product code. For more information about safety applications see details on page 225.

2	<b>R</b>	FM 238-M2	2x(1NO-1NC)	FM 238-W3M2	2x(1NO-1NC)
5	<b>R</b>	FM 538-M2	1NO+1NC	/	/
6	<b>L</b>	FM 638-M2	1NO+1NC	FM 638-W3M2	1NO+1NC
7	<b>LO</b>	FM 738-M2	1NO+1NC	/	/
9	<b>L</b>	FM 938-M2	2NC	FM 938-W3M2	2NC
10	<b>L</b>	FM 1038-M2	2NO	FM 1038-W3M2	2NO
11	<b>R</b>	FM 1138-M2	2NC	/	/
12	<b>R</b>	FM 1238-M2	2NO	/	/
13	<b>LV</b>	FM 1338-M2	2NC	/	/
14	<b>LS</b>	FM 1438-M2	2NC	/	/
15	<b>LS</b>	FM 1538-M2	2NO	/	/
16	<b>LI</b>	FM 1638-M2	2NC	/	/
18	<b>LA</b>	FM 1838-M2	1NO+1NC	/	/
20	<b>L</b>	FM 2038-M2	1NO+2NC	FM 2038-W3M2	1NO+2NC
21	<b>L</b>	FM 2138-M2	3NC	FM 2138-W3M2	3NC
22	<b>L</b>	FM 2238-M2	2NO+1NC	FM 2238-W3M2	2NO+1NC
E1	<b>LA</b>	FM E138-M2	1NO-1NC	/	/
Actuating force		0.06 Nm (0.25 Nm )		0.07 Nm (0.25 Nm )	
Travel diagrams		page 232 - group 5		page 231 - group 4	

## Separate actuators

**IMPORTANT:** These separate actuators can be used only with items of the FR, FM, FX, FZ and FK series.

Technopolymer roller Ø 18 mm	Technopolymer roller Ø 18 mm	Technopolymer roller Ø 14 mm	Technopolymer roller Ø 14 mm	Technopolymer roller Ø 20 mm	Technopolymer roller Ø 20 mm
VN A00KA	VN A00KB	VN A00KC	VN A00KD	VN A00KE	VN A00KF
Technopolymer roller Ø 20 mm	Technopolymer roller Ø 20 mm	Adjustable safety actuator with technopolymer roller	Adjustable square rod, 3x3x125 mm	Adjustable round rod Ø 3x125 mm	Adjustable glass fibre rod
VN A00KG	VN A00KH	VN A00KP	VN A00LB	VN A00LE	VN A00LH
Spring rod with plastic tip	Porcelain roller	Technopolymer roller Ø 14 mm	Technopolymer roller Ø 14 mm	Technopolymer roller Ø 20 mm	Adjustable safety lever with technopolymer roller Ø 20 mm
		With metallic parts in stainless steel			
VN A00LL	VN A00LP	VN A00KB-V38	VN A00KE-V38	VN A00KG-V38	VN A00KP-V38

All values in the drawings are in mm

Accessories See page 207

→ The 2D and 3D files are available at [www.pizzato.com](http://www.pizzato.com)



## Special separate actuators

**IMPORTANT:** These separate actuators can be used only with items of the FR, FM, FX, FZ and FK series.

Steel rollers, Ø 20 mm, with self-lubrication					
VN A00KB-R24 (1)	VN A00KE-R24 (1)	VN A00KF-R24 (1)	VN A00KG-R24 (1)	VN A00KH-R24 (1)	VN A00KP-R24 (1)

**Note:** To order with 316L stainless steel roller: replace R24 with R41 in the order numbers.

Technopolymer rollers, Ø 35 mm					
VN A00KB-R25 (1)	VN A00KE-R25 (1)	VN A00KF-R25 (1)	VN A00KG-R25 (1)	VN A00KH-R25 (1)	VN A00KP-R25 (1)

Rubber rollers, Ø 40 mm					
VN A00KB-R5 (1)	VN A00KE-R5 (1)	VN A00KF-R5 (1)	VN A00KG-R5 (1)	VN A00KH-R5 (1)	VN A00KP-R5 (1)

Rubber rollers, Ø 50 mm				
VN A00KE-R26 (1)	VN A00KF-R26 (1)	VN A00KG-R26 (1)	VN A00KH-R26 (1)	VN A00KP-R26 (1)

Protruding rubber rollers, Ø 50 mm
VN A00KP-R27 (1)

- (1) The actuator cannot be rotated to the inside because it will hit the switch head upon actuation.

- (2) The position switch obtained by assembling switch FM •38-M2 (e.g. FM 538-M2, FM 638-M2, ...) with actuator VN A00LP will not present the same travel diagrams and actuating forces as switch FM •53-E0M2V9 (e.g. FM 553-E0M2V9, FM 653-E0M2V9, ...).

**Note:** To check the correspondence with previous lever codes, please consult the table "Changed article codes" on page 289. Example: VF LE30 -> VN A00KA.

Selection diagram

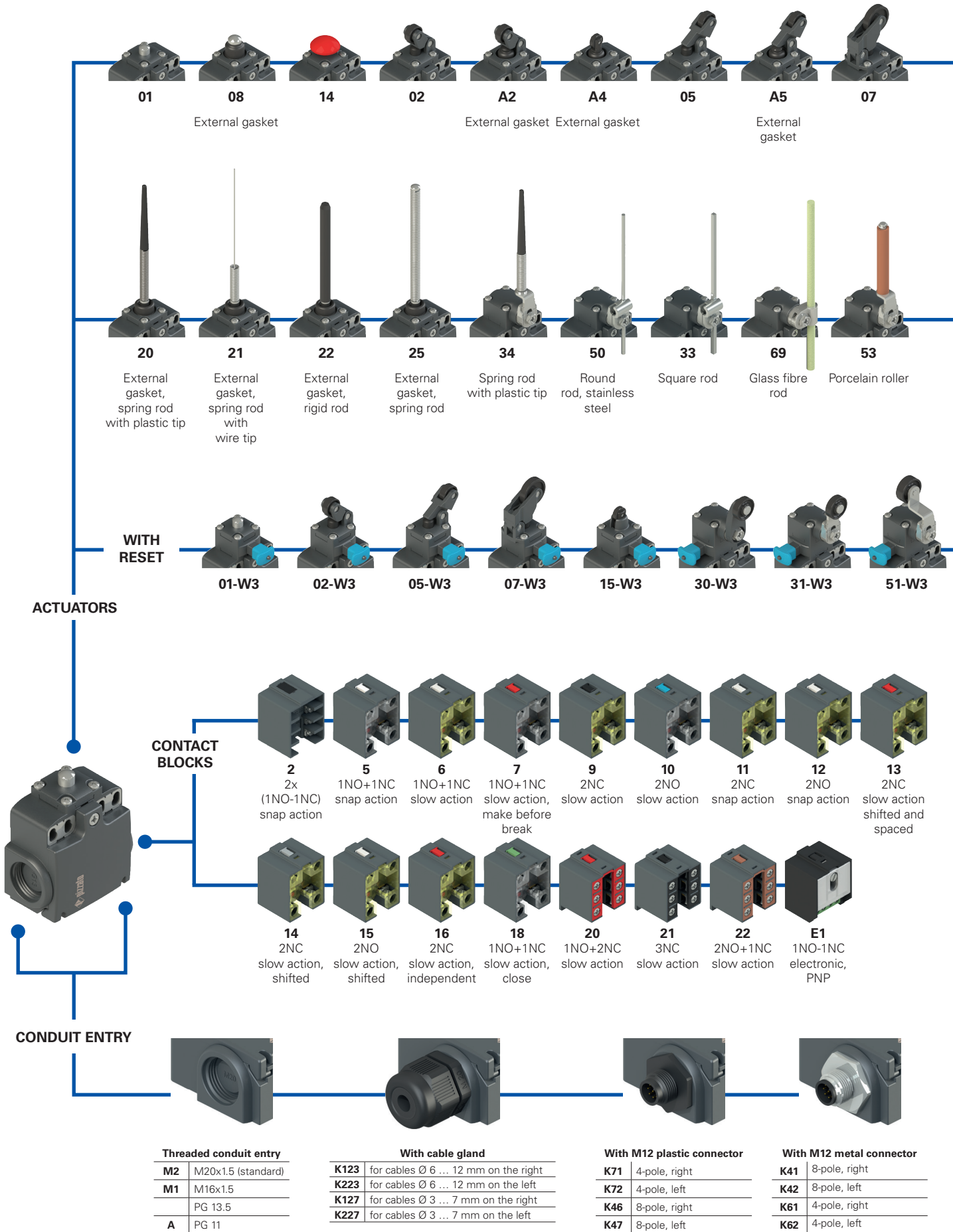

● Product options  
→ Sold separately as accessory





**A7** External gasket  
**15** Roller Ø 11 mm  
**15-R28** Steel roller, Ø 12 mm, with self-lubrication  
**16** Roller Ø 20 mm  
**12**  
**13** Steel roller, Ø 12 mm, with self-lubrication  
**76** Rope switch for signalling

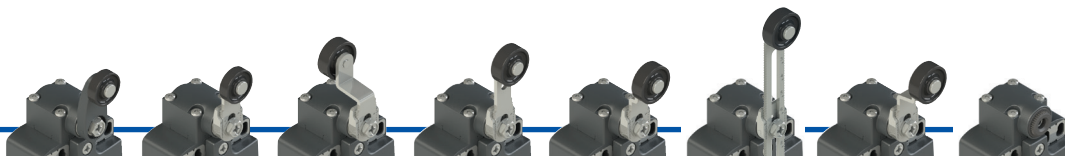

**30**  
**31**  
**51**  
**52**  
**54**  
**56** Adjustable safety lever  
**57**  
**38** Without actuator

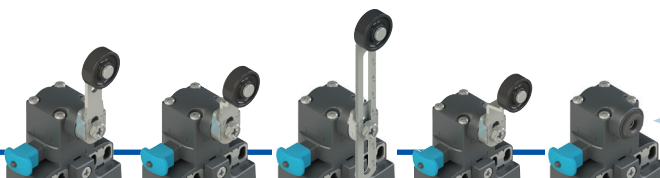

**52-W3**  
**54-W3**  
**56-W3**  
**57-W3**  
**38-W3** Without actuator



**SEPARATE ACTUATORS**  
See page 89

### Code structure

**Attention!** The feasibility of a code number does not mean the effective availability of a product. Please contact our sales office.

article options options  
**FX 502-W3XGM2K71R23T6**

Ambient temperature	
	-25°C ... +80°C (standard)
<b>T6</b>	-40°C ... +80°C

Housing	
<b>FX</b>	technopolymer, two conduit entries

Contact block	
<b>5</b>	1NO+1NC, snap action
<b>6</b>	1NO+1NC, slow action
<b>7</b>	1NO+1NC, slow action, make before break
...	...

Actuators	
<b>01</b>	short plunger
<b>02</b>	roller lever
<b>05</b>	angled lever with roller
...	...

Reset	
	without reset (standard)
<b>W3</b>	simultaneous reset
<b>W4</b>	simultaneous reset, increased force

External metallic parts	
	zinc-plated steel (standard)
<b>X</b>	stainless steel

Pre-installed cable glands or connectors	
	no cable gland or connector (standard)
<b>K123</b>	cable gland for cables Ø 6 ... 12 mm on the right
<b>K71</b>	M12 plastic connector, 4-pole, right

For the complete list of possible combinations please contact our technical department.

Threaded conduit entry	
<b>M2</b>	M20x1.5 (standard)
<b>M1</b>	M16x1.5
	PG 13.5
<b>A</b>	PG11

Rollers	
	standard roller
<b>R28</b>	Steel, with self-lubrication, Ø 12 mm (for actuators A4, 15)
<b>R44</b>	316L stainless steel, Ø 12 mm (for actuators A4, 13, 15)
<b>R23</b>	Steel, with self-lubrication, Ø 14 mm (for actuators A2, 02, A5, 05, 30, 31, 51, 52, 54, 55, 56, 57)
<b>R43</b>	316L stainless steel, Ø 14 mm (for actuators A2, 02, A5, 05, 30, 31, 51, 52, 54, 55, 56, 57)
<b>R24</b>	Steel, with self-lubrication, Ø 20 mm (for actuators 30, 31, 51, 52, 54, 55, 56, 57)
<b>R41</b>	316L stainless steel, Ø 20 mm (for actuators 30, 31, 51, 52, 54, 55, 56, 57)
<b>R36</b>	Steel, with self-lubrication, Ø 16 mm (for actuators 30, 31, 51, 52, 54, 55, 56, 57) technopolymer, Ø 35 mm
<b>R25</b>	rubber, Ø 40 mm (for actuators 30, 31, 51, 52, 54, 55, 56, 57)
<b>R5</b>	rubber, Ø 50 mm (for actuators 30, 31, 51, 52, 54, 55, 56, 57)
<b>R26</b>	rubber, protruding, Ø 50 mm (for actuators 51, 52, 54, 55, 56, 57)
<b>R27</b>	rubber, protruding, Ø 50 mm (for actuators 55, 56)

Contact type	
	silver contacts (standard)
<b>G</b>	silver contacts, 1 µm gold coating
<b>G1</b>	silver contacts, 2.5 µm gold coating (not for contact block 2, 20, 21, 22)

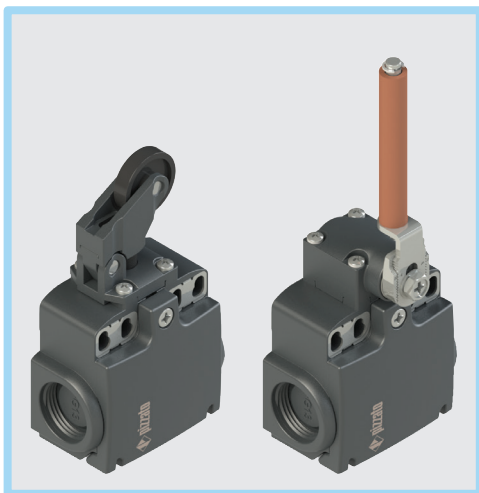

### Main features

- Technopolymer housing, two conduit entries
- Hinged cover, fixed with single captive screw
- Metal plates on mounting holes of the housing
- Protection degree IP67 and up to IP69K for actuators without external gasket
- 17 contact blocks available
- 45 actuators available
- Versions with external parts in stainless steel
- Versions with M12 connector
- Versions with gold-plated silver contacts

### Quality marks:



IMQ approval:	EG610
UL approval:	E131787
CCC approval:	2021000305000101
EAC approval:	RU C-IT.YT03.B.00035/19

### Installation for safety applications:

Use only switches marked with the  $\ominus$  symbol beside the product code. Always connect the safety circuit to the **NC contacts** (normally closed contacts: 11-12, 21-22 or 31-32) as required by **EN ISO 14119, paragraph 5.4** for specific interlock applications and **EN ISO 13849-2 tables D3** (well-ried components) and **D.8** (fault exclusions) for safety applications in general. Actuate the switch **at least up to the positive opening travel** shown in the travel diagrams on page 232. Actuate the switch **at least with the positive opening force**, reported in brackets below each article, next to the actuating force value.

**⚠ If not expressly indicated in this chapter, for correct installation and utilization of all articles see the instructions given on pages 227 to 242.**

### Technical data

#### Housing

Housing made of glass fibre reinforced technopolymer, self-extinguishing, shock-proof and with double insulation:  $\square$

Two knock-out threaded conduit entries.	M20x1.5 (standard)
Protection degree:	IP67 acc. to EN 60529 (with cable gland of equal or higher protection degree)
Protection degree with actuators 01, 02, 05, 07, 10, 12, 13, 14, 15, 15-R28, 16, 17, 30, 31, 33, 34, 38, 50, 51, 52, 53, 54, 56, 57, 69, 76:	IP69K acc. to ISO 20653 (with cable gland of equal or higher protection degree)

#### General data

Ambient temperature:	-25°C ... +80°C (standard) -40°C ... +80°C (T6 option)
Max. actuation frequency:	3600 operating cycles/hour
Mechanical endurance:	20 million operating cycles
Mounting position:	any
Safety parameter $B_{10D}$ :	40,000,000 for NC contacts
Mechanical interlock, not coded:	type 1 acc. to EN ISO 14119
Tightening torques for installation:	see page 231
Wire cross-sections and wire stripping lengths:	see page 249

#### In compliance with standards:

IEC 60947-5-1, EN 60947-5-1, EN 60947-1, IEC 60204-1, EN 60204-1, EN ISO 14119, EN ISO 12100, IEC 60529, EN 60529, EN IEC 63000, UL 508, CSA C22.2 No. 14.

#### Approvals:

IEC 60947-5-1, UL 508, CSA C22.2 No. 14, GB/T14048.5.

#### Compliance with the requirements of:

Low Voltage Directive 2014/35/EU, EMC Directive 2014/30/EU, RoHS Directive 2011/65/EU.

#### Positive contact opening in conformity with standards:

IEC 60947-5-1, EN 60947-5-1.

### Electrical data

### Utilization category

without connector	Thermal current ( $I_{th}$ ):	10 A	Alternating current: AC15 (50±60 Hz)			
	Rated insulation voltage ( $U_r$ ):	500 Vac 600 Vdc 400 Vac 500 Vdc (contact blocks 2, 11, 12, 20, 21, 22)	Ue (V)	250	400	500
	Rated impulse withstand voltage ( $U_{imp}$ ):	6 kV 4 kV (contact blocks 20, 21, 22)	Ie (A)	6	4	1
	Conditional short circuit current: Protection against short circuits: Pollution degree:	1000 A acc. to EN 60947-5-1 type aM fuse 10 A 500 V 3	Direct current: DC13	Ue (V)	24	125

Ie (A)	3	0.55	0.3
--------	---	------	-----

with M12 connector, 4-pole	Thermal current ( $I_{th}$ ):	4 A	Alternating current: AC15 (50±60 Hz)			
	Rated insulation voltage ( $U_r$ ):	250 Vac 300 Vdc	Ue (V)	24	120	250
	Protection against short circuits: Pollution degree:	type gG fuse 4 A 500 V 3	Ie (A)	4	4	4
			Direct current: DC13	Ue (V)	24	125

Ie (A)	3	0.55	0.3
--------	---	------	-----

with M12 connector, 8-pole	Thermal current ( $I_{th}$ ):	2 A	Alternating current: AC15 (50±60 Hz)			
	Rated insulation voltage ( $U_r$ ):	30 Vac 36 Vdc	Ue (V)	24		
	Protection against short circuits: Pollution degree:	type gG fuse 2 A 500 V 3	Ie (A)	2		
			Direct current: DC13	Ue (V)	24	

Ie (A)	2		
--------	---	--	--



### Features approved by IMQ

Rated insulation voltage (U<sub>i</sub>): 500 Vac  
 400 Vac (for contact blocks 2, 11, 12, 20, 21, 22, 28, 29, 30, 37, 33, 34)

Conventional free air thermal current (I<sub>th</sub>): 10 A

Protection against short circuits: type aM fuse 10 A 500 V

Rated impulse withstand voltage (U<sub>imp</sub>): 6 kV  
 4 kV (for contact blocks 20, 21, 22, 28, 29, 30, 33, 34)

Protection degree of the housing: IP67

MV terminals (screw terminals) Pollution degree: 3

Utilization category: AC15

Operating voltage (U<sub>e</sub>): 400 Vac (50 Hz)

Operating current (I<sub>e</sub>): 3 A

Forms of the contact element: Za, Za+Za, X+X, Zb, Y+Y, Y+Y+X, Y+Y+Y, Y+X+X, Y, X.

Positive opening of contacts on contact blocks 5, 6, 7, 8, 9, 11, 13, 14, 16, 17, 18, 19, 20, 21, 22, 28, 29, 30, 33, 34, 37, 38, 39, 66.

In compliance with standards: EN 60947-1, EN 60947-5-1, fundamental requirements of the Low Voltage Directive 2014/35/EU.

Please contact our technical department for the list of approved products.

### Features approved by UL

Electrical Ratings: Q300 pilot duty (69 VA, 125-250 V dc)  
 A600 pilot duty (720 VA, 120-600 V ac)

Environmental Ratings: Types 1, 4X, 12, 13

For all contact blocks except 2 and 3 use 60 or 75°C copper (Cu) conductors, rigid or flexible, wire size 12, 14 AWG. Tightening torque for terminal screws of 7.1 lb in (0.8 Nm).

For contact blocks 2 and 3 use 60 or 75°C copper (Cu) conductors, rigid or flexible, wire size 14 AWG. Tightening torque for terminal screws of 12 lb in (1.4 Nm).

The hub is to be connected to the conduit before the hub is connected to the enclosure.

Please contact our technical department for the list of approved products.

### Wiring diagram for M12 connectors

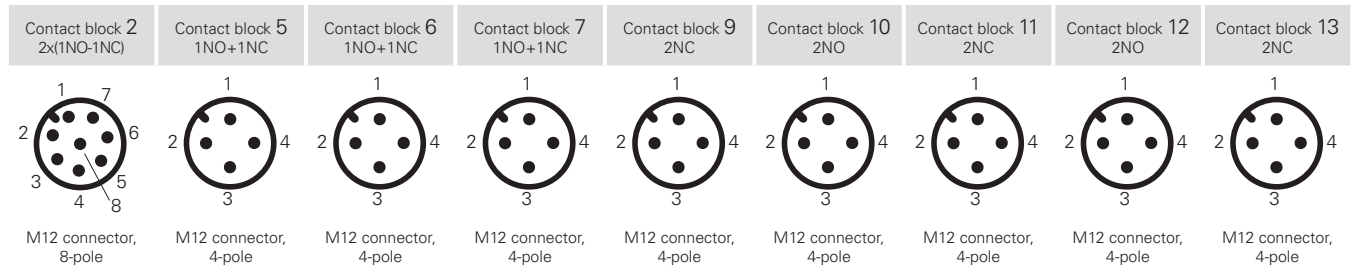

Contacts	Pin no.	Contacts	Pin no.	Contacts	Pin no.	Contacts	Pin no.	Contacts	Pin no.	Contacts	Pin no.	Contacts	Pin no.
NO	3-4	NC	1-2	NC	1-2	NC	1-2	NC	1-2	NO	1-2	NC (1°)	1-2
NC	5-6	NO	3-4	NO	3-4	NO	3-4	NO	3-4	NC	3-4	NO	3-4
NC	7-8												
NO	1-2												

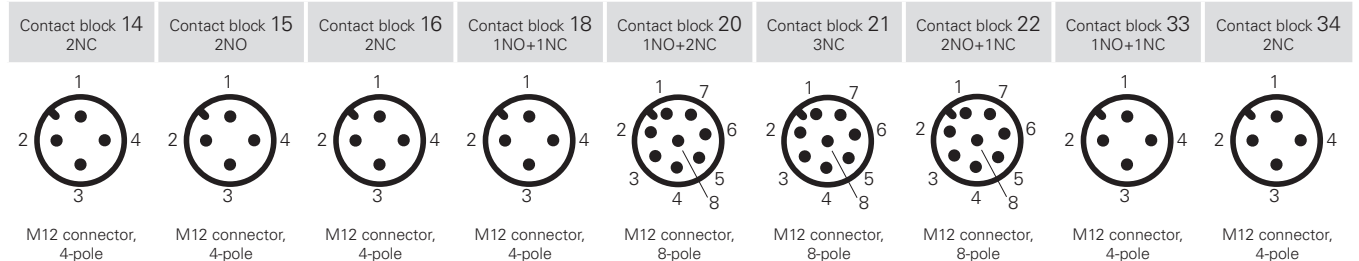

Contacts	Pin no.	Contacts	Pin no.	Contacts	Pin no.	Contacts	Pin no.	Contacts	Pin no.	Contacts	Pin no.	Contacts	Pin no.
NC (1°)	1-2	NO (1°)	1-2	NC, lever to the right	1-2	NC	1-2	NC	3-4	NC	3-4	NC	1-2
NC (2°)	3-4	NO (2°)	3-4	NC, lever to the left	3-4	NO	3-4	NC	5-6	NC	5-6	NO	3-4
									NO	7-8	NC	7-8	

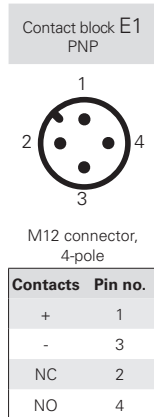

# FX series position switches

- Contact type
- R** = snap action
  - L** = slow action
  - LO** = slow action, make before break
  - LS** = slow action, shifted
  - LV** = slow action, shifted and spaced
  - LI** = slow action, independent
  - LA** = slow action, close
  - ⚡** = electronic, PNP

Contact block

		With steel roller with self-lubrication or 316L stainless steel on request		External gasket		External gasket			
		With steel roller with self-lubrication or 316L stainless steel on request		With steel roller with self-lubrication or 316L stainless steel on request		With Ø 12 mm steel roller with self-lubrication or 316L stainless steel on request			
2	<b>R</b>	FX 201-M2	2x(1NO-1NC)	FX 202-M2	2x(1NO-1NC)	FX 2A2-M2	2x(1NO-1NC)	FX 2A4-M2	2x(1NO-1NC)
5	<b>R</b>	FX 501-M2	1NO+1NC	FX 502-M2	1NO+1NC	FX 5A2-M2	1NO+1NC	FX 5A4-M2	1NO+1NC
6	<b>L</b>	FX 601-M2	1NO+1NC	FX 602-M2	1NO+1NC	FX 6A2-M2	1NO+1NC	FX 6A4-M2	1NO+1NC
7	<b>LO</b>	FX 701-M2	1NO+1NC	FX 702-M2	1NO+1NC	FX 7A2-M2	1NO+1NC	FX 7A4-M2	1NO+1NC
9	<b>L</b>	FX 901-M2	2NC	FX 902-M2	2NC	FX 9A2-M2	2NC	FX 9A4-M2	2NC
10	<b>L</b>	FX 1001-M2	2NO	FX 1002-M2	2NO	FX 10A2-M2	2NO	FX 10A4-M2	2NO
11	<b>R</b>	FX 1101-M2	2NC	FX 1102-M2	2NC	FX 11A2-M2	2NC	FX 11A4-M2	2NC
12	<b>R</b>	FX 1201-M2	2NO	FX 1202-M2	2NO	FX 12A2-M2	2NO	FX 12A4-M2	2NO
13	<b>LV</b>	FX 1301-M2	2NC	FX 1302-M2	2NC	FX 13A2-M2	2NC	FX 13A4-M2	2NC
14	<b>LS</b>	FX 1401-M2	2NC	FX 1402-M2	2NC	FX 14A2-M2	2NC	FX 14A4-M2	2NC
15	<b>LS</b>	FX 1501-M2	2NO	FX 1502-M2	2NO	FX 15A2-M2	2NO	FX 15A4-M2	2NO
18	<b>LA</b>	FX 1801-M2	1NO+1NC	FX 1802-M2	1NO+1NC	FX 18A2-M2	1NO+1NC	FX 18A4-M2	1NO+1NC
20	<b>L</b>	FX 2001-M2	1NO+2NC	FX 2002-M2	1NO+2NC	FX 20A2-M2	1NO+2NC	FX 20A4-M2	1NO+2NC
21	<b>L</b>	FX 2101-M2	3NC	FX 2102-M2	3NC	FX 21A2-M2	3NC	FX 21A4-M2	3NC
22	<b>L</b>	FX 2201-M2	2NO+1NC	FX 2202-M2	2NO+1NC	FX 22A2-M2	2NO+1NC	FX 22A4-M2	2NO+1NC
E1	<b>⚡</b>	FX E101-M2	1NO-1NC	FX E102-M2	1NO-1NC	FX E1A2-M2	1NO-1NC	FX E1A4-M2	1NO-1NC
Max. speed		page 231 - type 4		page 231 - type 3		page 231 - type 3		page 231 - type 5	
Actuating force		8 N (25 N ⊕)		6 N (25 N ⊕)		4.3 N (25 N ⊕)		4.3 N (25 N ⊕)	
Travel diagrams		page 232 - group 1		page 232 - group 2		page 232 - group 2		page 232 - group 1	

- Contact type
- R** = snap action
  - L** = slow action
  - LO** = slow action, make before break
  - LS** = slow action, shifted
  - LV** = slow action, shifted and spaced
  - LI** = slow action, independent
  - LA** = slow action, close
  - ⚡** = electronic, PNP

Contact block

		With steel roller with self-lubrication or 316L stainless steel on request		External gasket		External gasket		External gasket	
		With steel roller with self-lubrication or 316L stainless steel on request		With steel roller with self-lubrication or 316L stainless steel on request		With steel roller with self-lubrication or 316L stainless steel on request		With Ø 12 mm steel roller with self-lubrication or 316L stainless steel on request	
2	<b>R</b>	FX 205-M2	2x(1NO-1NC)	FX 2A5-M2	2x(1NO-1NC)	FX 207-M2	2x(1NO-1NC)	FX 2A7-M2	2x(1NO-1NC)
5	<b>R</b>	FX 505-M2	1NO+1NC	FX 5A5-M2	1NO+1NC	FX 507-M2	1NO+1NC	FX 5A7-M2	1NO+1NC
6	<b>L</b>	FX 605-M2	1NO+1NC	FX 6A5-M2	1NO+1NC	FX 607-M2	1NO+1NC	FX 6A7-M2	1NO+1NC
7	<b>LO</b>	FX 705-M2	1NO+1NC	FX 7A5-M2	1NO+1NC	FX 707-M2	1NO+1NC	FX 7A7-M2	1NO+1NC
9	<b>L</b>	FX 905-M2	2NC	FX 9A5-M2	2NC	FX 907-M2	2NC	FX 9A7-M2	2NC
10	<b>L</b>	FX 1005-M2	2NO	FX 10A5-M2	2NO	FX 1007-M2	2NO	FX 10A7-M2	2NO
11	<b>R</b>	FX 1105-M2	2NC	FX 11A5-M2	2NC	FX 1107-M2	2NC	FX 11A7-M2	2NC
12	<b>R</b>	FX 1205-M2	2NO	FX 12A5-M2	2NO	FX 1207-M2	2NO	FX 12A7-M2	2NO
13	<b>LV</b>	FX 1305-M2	2NC	FX 13A5-M2	2NC	FX 1307-M2	2NC	FX 13A7-M2	2NC
14	<b>LS</b>	FX 1405-M2	2NC	FX 14A5-M2	2NC	FX 1407-M2	2NC	FX 14A7-M2	2NC
15	<b>LS</b>	FX 1505-M2	2NO	FX 15A5-M2	2NO	FX 1507-M2	2NO	FX 15A7-M2	2NO
18	<b>LA</b>	FX 1805-M2	1NO+1NC	FX 18A5-M2	1NO+1NC	FX 1807-M2	1NO+1NC	FX 18A7-M2	1NO+1NC
20	<b>L</b>	FX 2005-M2	1NO+2NC	FX 20A5-M2	1NO+2NC	FX 2007-M2	1NO+2NC	FX 20A7-M2	1NO+2NC
21	<b>L</b>	FX 2105-M2	3NC	FX 21A5-M2	3NC	FX 2107-M2	3NC	FX 21A7-M2	3NC
22	<b>L</b>	FX 2205-M2	2NO+1NC	FX 22A5-M2	2NO+1NC	FX 2207-M2	2NO+1NC	FX 22A7-M2	2NO+1NC
E1	<b>⚡</b>	FX E105-M2	1NO-1NC	FX E1A5-M2	1NO-1NC	FX E107-M2	1NO-1NC	FX E1A7-M2	1NO-1NC
Max. speed		page 231 - type 3		page 231 - type 3		page 231 - type 3		page 231 - type 3	
Actuating force		6 N (25 N ⊕)		4.3 N (25 N ⊕)		4 N (25 N ⊕)		3 N (25 N ⊕)	
Travel diagrams		page 232 - group 2		page 232 - group 2		page 232 - group 3		page 232 - group 3	

All values in the drawings are in mm

Accessories See page 207

→ The 2D and 3D files are available at [www.pizzato.com](http://www.pizzato.com)

- Contact type
- R** = snap action
  - L** = slow action
  - LO** = slow action, make before break
  - LS** = slow action, shifted
  - LV** = slow action, shifted and spaced
  - LI** = slow action, independent
  - LA** = slow action, close
  - E1** = electronic, PNP

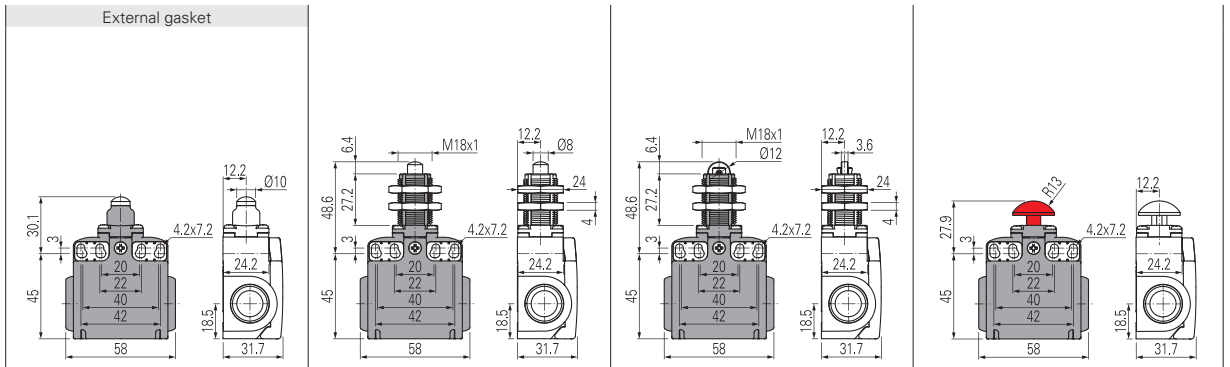

Contact block	Contact type	Model	Configuration	Model	Configuration	Model	Configuration	Model	Configuration
2	R	FX 208-M2	2x(1NO-1NC)	FX 212-M2	2x(1NO-1NC)	FX 213-M2	2x(1NO-1NC)	FX 214-M2	2x(1NO-1NC)
5	R	FX 508-M2	1NO+1NC	FX 512-M2	1NO+1NC	FX 513-M2	1NO+1NC	FX 514-M2	1NO+1NC
6	L	FX 608-M2	1NO+1NC	FX 612-M2	1NO+1NC	FX 613-M2	1NO+1NC	FX 614-M2	1NO+1NC
7	LO	FX 708-M2	1NO+1NC	FX 712-M2	1NO+1NC	FX 713-M2	1NO+1NC	FX 714-M2	1NO+1NC
9	L	FX 908-M2	2NC	FX 912-M2	2NC	FX 913-M2	2NC	FX 914-M2	2NC
10	L	FX 1008-M2	2NO	FX 1012-M2	2NO	FX 1013-M2	2NO	FX 1014-M2	2NO
11	R	FX 1108-M2	2NC	FX 1112-M2	2NC	FX 1113-M2	2NC	FX 1114-M2	2NC
12	R	FX 1208-M2	2NO	FX 1212-M2	2NO	FX 1213-M2	2NO	FX 1214-M2	2NO
13	LV	FX 1308-M2	2NC	FX 1312-M2	2NC	FX 1313-M2	2NC	FX 1314-M2	2NC
14	LS	FX 1408-M2	2NC	FX 1412-M2	2NC	FX 1413-M2	2NC	FX 1414-M2	2NC
15	LS	FX 1508-M2	2NO	FX 1512-M2	2NO	FX 1513-M2	2NO	FX 1514-M2	2NO
18	LA	FX 1808-M2	1NO+1NC	FX 1812-M2	1NO+1NC	FX 1813-M2	1NO+1NC	FX 1814-M2	1NO+1NC
20	L	FX 2008-M2	1NO+2NC	FX 2012-M2	1NO+2NC	FX 2013-M2	1NO+2NC	FX 2014-M2	1NO+2NC
21	L	FX 2108-M2	3NC	FX 2112-M2	3NC	FX 2113-M2	3NC	FX 2114-M2	3NC
22	L	FX 2208-M2	2NO+1NC	FX 2212-M2	2NO+1NC	FX 2213-M2	2NO+1NC	FX 2214-M2	2NO+1NC
E1	E1	FX E108-M2	1NO-1NC	FX E112-M2	1NO-1NC	FX E113-M2	1NO-1NC	FX E114-M2	1NO-1NC
Max. speed		page 231 - type 4		page 231 - type 4		page 231 - type 2		page 231 - type 4	
Actuating force		8 N (25 N)		8 N (25 N)		8 N (25 N)		8 N (25 N)	
Travel diagrams		page 232 - group 1		page 232 - group 1		page 232 - group 1		page 232 - group 1	

- Contact type
- R** = snap action
  - L** = slow action
  - LO** = slow action, make before break
  - LS** = slow action, shifted
  - LV** = slow action, shifted and spaced
  - LI** = slow action, independent
  - LA** = slow action, close
  - E1** = electronic, PNP

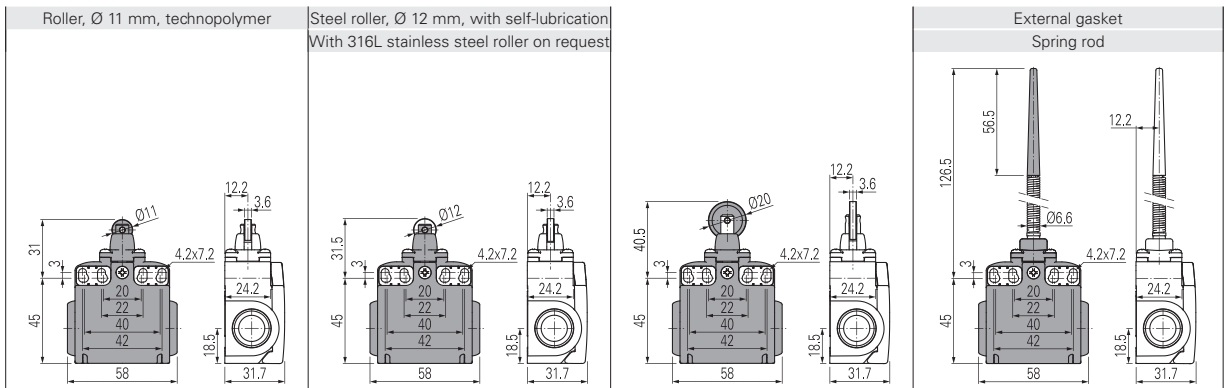

Contact block	Contact type	Model	Configuration	Model	Configuration	Model	Configuration	Model	Configuration
2	R	FX 215-M2	2x(1NO-1NC)	FX 215-M2R28	2x(1NO-1NC)	FX 216-M2	2x(1NO-1NC)	FX 220-M2	2x(1NO-1NC)
5	R	FX 515-M2	1NO+1NC	FX 515-M2R28	1NO+1NC	FX 516-M2	1NO+1NC	FX 520-M2	1NO+1NC
6	L	FX 615-M2	1NO+1NC	FX 615-M2R28	1NO+1NC	FX 616-M2	1NO+1NC	/	/
7	LO	FX 715-M2	1NO+1NC	FX 715-M2R28	1NO+1NC	FX 716-M2	1NO+1NC	/	/
9	L	FX 915-M2	2NC	FX 915-M2R28	2NC	FX 916-M2	2NC	/	/
10	L	FX 1015-M2	2NO	FX 1015-M2R28	2NO	FX 1016-M2	2NO	FX 1020-M2	2NO
11	R	FX 1115-M2	2NC	FX 1115-M2R28	2NC	FX 1116-M2	2NC	/	/
12	R	FX 1215-M2	2NO	FX 1215-M2R28	2NO	FX 1216-M2	2NO	FX 1220-M2	2NO
13	LV	FX 1315-M2	2NC	FX 1315-M2R28	2NC	FX 1316-M2	2NC	/	/
14	LS	FX 1415-M2	2NC	FX 1415-M2R28	2NC	FX 1416-M2	2NC	/	/
15	LS	FX 1515-M2	2NO	FX 1515-M2R28	2NO	FX 1516-M2	2NO	/	/
18	LA	FX 1815-M2	1NO+1NC	FX 1815-M2R28	1NO+1NC	FX 1816-M2	1NO+1NC	FX 1820-M2	1NO+1NC
20	L	FX 2015-M2	1NO+2NC	FX 2015-M2R28	1NO+2NC	FX 2016-M2	1NO+2NC	FX 2020-M2	1NO+2NC
21	L	FX 2115-M2	3NC	FX 2115-M2R28	3NC	FX 2116-M2	3NC	FX 2120-M2	3NC
22	L	FX 2215-M2	2NO+1NC	FX 2215-M2R28	2NO+1NC	FX 2216-M2	2NO+1NC	FX 2220-M2	2NO+1NC
E1	E1	FX E115-M2	1NO-1NC	FX E115-M2R28	1NO-1NC	FX E116-M2	1NO-1NC	FX E120-M2	1NO-1NC
Max. speed		page 231 - type 2		page 231 - type 2		page 231 - type 2		1 m/s	
Actuating force		8 N (25 N)		8 N (25 N)		8 N (25 N)		0.07 Nm	
Travel diagrams		page 232 - group 1		page 232 - group 1		page 232 - group 1		page 232 - group 4	

All values in the drawings are in mm



Accessories See page 207

The 2D and 3D files are available at [www.pizzato.com](http://www.pizzato.com)

# FX series position switches



- Contact type**  
**R** = snap action  
**L** = slow action  
**LO** = slow action, make before break  
**LS** = slow action, shifted  
**LV** = slow action, shifted and spaced  
**LI** = slow action, independent  
**LA** = slow action, close  
 = electronic, PNP

**Contact block**

		External gasket Spring rod	External gasket Rigid rod	External gasket Spring rod	With Ø 20 mm steel roller with self-lubrication or 316L stainless steel on request
2	<b>R</b>	FX 221-M2 2x(1NO-1NC)	FX 222-M2 2x(1NO-1NC)	FX 225-M2 2x(1NO-1NC)	FX 230-M2 2x(1NO-1NC)
5	<b>R</b>	FX 521-M2 1NO+1NC	/	FX 525-M2 1NO+1NC	FX 530-M2 1NO+1NC
6	<b>L</b>	/	/	/	FX 630-M2 1NO+1NC
7	<b>LO</b>	/	/	/	FX 730-M2 1NO+1NC
9	<b>L</b>	/	/	/	FX 930-M2 2NC
10	<b>L</b>	FX 1021-M2 2NO	FX 1022-M2 2NO	FX 1025-M2 2NO	FX 1030-M2 2NO
11	<b>R</b>	/	/	/	FX 1130-M2 2NC
12	<b>R</b>	FX 1221-M2 2NO	FX 1222-M2 2NO	FX 1225-M2 2NO	FX 1230-M2 2NO
13	<b>LV</b>	/	/	/	FX 1330-M2 2NC
14	<b>LS</b>	/	/	/	FX 1430-M2 2NC
15	<b>LS</b>	/	/	/	FX 1530-M2 2NO
16	<b>LI</b>	/	/	/	FX 1630-M2 2NC
18	<b>LA</b>	FX 1821-M2 1NO+1NC	FX 1822-M2 1NO+1NC	FX 1825-M2 1NO+1NC	FX 1830-M2 1NO+1NC
20	<b>L</b>	FX 2021-M2 1NO+2NC	FX 2022-M2 1NO+2NC	FX 2025-M2 1NO+2NC	FX 2030-M2 1NO+2NC
21	<b>L</b>	FX 2121-M2 3NC	FX 2122-M2 3NC	FX 2125-M2 3NC	FX 2130-M2 3NC
22	<b>L</b>	FX 2221-M2 2NO+1NC	FX 2222-M2 2NO+1NC	FX 2225-M2 2NO+1NC	FX 2230-M2 2NO+1NC
E1		FX E121-M2 1NO-1NC	FX E122-M2 1NO-1NC	FX E125-M2 1NO-1NC	FX E130-M2 1NO-1NC
Max. speed		1 m/s	1 m/s	1 m/s	page 231 - type 1
Actuating force		0.07 Nm	0.12 Nm (0.25 Nm  )	0.12 Nm	0.06 Nm (0.25 Nm  )
Travel diagrams		page 232 - group 4	page 232 - group 4	page 232 - group 4	page 232 - group 5

- Contact type**  
**R** = snap action  
**L** = slow action  
**LO** = slow action, make before break  
**LS** = slow action, shifted  
**LV** = slow action, shifted and spaced  
**LI** = slow action, independent  
**LA** = slow action, close  
 = electronic, PNP

**Contact block**

		Other rollers available. See page 90	Square rod, 3x3 mm	Round rod, Ø 3 mm, stainless steel
2	<b>R</b>	FX 231-M2 2x(1NO-1NC)	FX 233-M2 2x(1NO-1NC)	FX 234-M2 2x(1NO-1NC)
5	<b>R</b>	FX 531-M2 1NO+1NC	FX 533-M2 1NO+1NC	FX 534-M2 1NO+1NC
6	<b>L</b>	FX 631-M2 1NO+1NC	FX 633-M2 1NO+1NC	FX 634-M2 1NO+1NC
7	<b>LO</b>	FX 731-M2 1NO+1NC	FX 733-M2 1NO+1NC	FX 734-M2 1NO+1NC
9	<b>L</b>	FX 931-M2 2NC	FX 933-M2 2NC	FX 934-M2 2NC
10	<b>L</b>	FX 1031-M2 2NO	FX 1033-M2 2NO	FX 1034-M2 2NO
11	<b>R</b>	FX 1131-M2 2NC	FX 1133-M2 2NC	FX 1134-M2 2NC
12	<b>R</b>	FX 1231-M2 2NO	FX 1233-M2 2NO	FX 1234-M2 2NO
13	<b>LV</b>	FX 1331-M2 2NC	FX 1333-M2 2NC	FX 1334-M2 2NC
14	<b>LS</b>	FX 1431-M2 2NC	FX 1433-M2 2NC	FX 1434-M2 2NC
15	<b>LS</b>	FX 1531-M2 2NO	FX 1533-M2 2NO	FX 1534-M2 2NO
16	<b>LI</b>	FX 1631-M2 2NC	FX 1633-M2 2NC	FX 1634-M2 2NC
18	<b>LA</b>	FX 1831-M2 1NO+1NC	FX 1833-M2 1NO+1NC	FX 1834-M2 1NO+1NC
20	<b>L</b>	FX 2031-M2 1NO+2NC	FX 2033-M2 1NO+2NC	FX 2034-M2 1NO+2NC
21	<b>L</b>	FX 2131-M2 3NC	FX 2133-M2 3NC	FX 2134-M2 3NC
22	<b>L</b>	FX 2231-M2 2NO+1NC	FX 2233-M2 2NO+1NC	FX 2234-M2 2NO+1NC
E1		FX E131-M2 1NO-1NC	FX E133-M2 1NO-1NC	FX E134-M2 1NO-1NC
Max. speed		page 231 - type 1	1.5 m/s	1.5 m/s
Actuating force		0.06 Nm (0.25 Nm  )	0.06 Nm	0.06 Nm
Travel diagrams		page 232 - group 5	page 232 - group 5	page 232 - group 5

All values in the drawings are in mm

Accessories See page 207

The 2D and 3D files are available at [www.pizzato.com](http://www.pizzato.com)



Contact type	Other rollers available. See page 90		Other rollers available. See page 90		Porcelain roller		Other rollers available. See page 90		
<ul style="list-style-type: none"> <li><b>R</b> = snap action</li> <li><b>L</b> = slow action</li> <li><b>LO</b> = slow action, make before break</li> <li><b>LS</b> = slow action, shifted</li> <li><b>LV</b> = slow action, shifted and spaced</li> <li><b>LI</b> = slow action, independent</li> <li><b>LA</b> = slow action, close</li> <li><b>Λ</b> = electronic, PNP</li> </ul>									
Contact block									
2	<b>R</b>	FX 251-M2	2x(1NO-1NC)	FX 252-M2	2x(1NO-1NC)	FX 253-E0M2	2x(1NO-1NC)	FX 254-M2	2x(1NO-1NC)
5	<b>R</b>	FX 551-M2	1NO+1NC	FX 552-M2	1NO+1NC	FX 553-E0M2V9	1NO+1NC	FX 554-M2	1NO+1NC
6	<b>L</b>	FX 651-M2	1NO+1NC	FX 652-M2	1NO+1NC	FX 653-E0M2V9	1NO+1NC	FX 654-M2	1NO+1NC
7	<b>LO</b>	FX 751-M2	1NO+1NC	FX 752-M2	1NO+1NC	FX 753-E0M2V9	1NO+1NC	FX 754-M2	1NO+1NC
9	<b>L</b>	FX 951-M2	2NC	FX 952-M2	2NC	FX 953-E0M2V9	2NC	FX 954-M2	2NC
10	<b>L</b>	FX 1051-M2	2NO	FX 1052-M2	2NO	FX 1053-E0M2V9	2NO	FX 1054-M2	2NO
11	<b>R</b>	FX 1151-M2	2NC	FX 1152-M2	2NC	/		FX 1154-M2	2NC
12	<b>R</b>	FX 1251-M2	2NO	FX 1252-M2	2NO	FX 1253-E0M2V9	2NO	FX 1254-M2	2NO
13	<b>LV</b>	FX 1351-M2	2NC	FX 1352-M2	2NC	FX 1353-E0M2V9	2NC	FX 1354-M2	2NC
14	<b>LS</b>	FX 1451-M2	2NC	FX 1452-M2	2NC	FX 1453-E0M2V9	2NC	FX 1454-M2	2NC
15	<b>LS</b>	FX 1551-M2	2NO	FX 1552-M2	2NO	FX 1553-E0M2V9	2NO	FX 1554-M2	2NO
16	<b>LI</b>	FX 1651-M2	2NC	FX 1652-M2	2NC	/		FX 1654-M2	2NC
18	<b>LA</b>	FX 1851-M2	1NO+1NC	FX 1852-M2	1NO+1NC	FX 1853-E0M2V9	1NO+1NC	FX 1854-M2	1NO+1NC
20	<b>L</b>	FX 2051-M2	1NO+2NC	FX 2052-M2	1NO+2NC	FX 2053-E0M2V9	1NO+2NC	FX 2054-M2	1NO+2NC
21	<b>L</b>	FX 2151-M2	3NC	FX 2152-M2	3NC	FX 2153-E0M2V9	3NC	FX 2154-M2	3NC
22	<b>L</b>	FX 2251-M2	2NO+1NC	FX 2252-M2	2NO+1NC	FX 2253-E0M2V9	2NO+1NC	FX 2254-M2	2NO+1NC
E1	<b>Λ</b>	FX E151-M2	1NO-1NC	FX E152-M2	1NO-1NC	FX E153-E0M2V9	1NO-1NC	FX E154-M2	1NO-1NC
Max. speed	page 231 - type 1		page 231 - type 1		0.5 m/s		page 231 - type 1		
Actuating force	0.06 Nm (0.25 Nm ⊕)		0.06 Nm (0.25 Nm ⊕)		0.03 Nm (0.25 Nm ⊕)		0.06 Nm (0.25 Nm ⊕)		
Travel diagrams	page 232 - group 5		page 232 - group 5		page 232 - group 6		page 232 - group 5		

Contact type	Other rollers available. See page 90		Other rollers available. See page 90		Glass fibre rod		Rope switch for signalling		
<ul style="list-style-type: none"> <li><b>R</b> = snap action</li> <li><b>L</b> = slow action</li> <li><b>LO</b> = slow action, make before break</li> <li><b>LS</b> = slow action, shifted</li> <li><b>LV</b> = slow action, shifted and spaced</li> <li><b>LI</b> = slow action, independent</li> <li><b>LA</b> = slow action, close</li> <li><b>Λ</b> = electronic, PNP</li> </ul>									
Contact block									
2	<b>R</b>	FX 256-M2	2x(1NO-1NC)	FX 257-M2	2x(1NO-1NC)	FX 269-M2	2x(1NO-1NC)	FX 276-M2	2x(1NO-1NC)
5	<b>R</b>	FX 556-M2	1NO+1NC	FX 557-M2	1NO+1NC	FX 569-M2	1NO+1NC	FX 576-M2	1NO+1NC
6	<b>L</b>	FX 656-M2	1NO+1NC	FX 657-M2	1NO+1NC	FX 669-M2	1NO+1NC	FX 676-M2	1NO+1NC
7	<b>LO</b>	FX 756-M2	1NO+1NC	FX 757-M2	1NO+1NC	FX 769-M2	1NO+1NC	FX 776-M2	1NO+1NC
9	<b>L</b>	FX 956-M2	2NC	FX 957-M2	2NC	FX 969-M2	2NC	FX 976-M2	2NO
10	<b>L</b>	FX 1056-M2	2NO	FX 1057-M2	2NO	FX 1069-M2	2NO	FX 1076-M2	2NC
11	<b>R</b>	FX 1156-M2	2NC	FX 1157-M2	2NC	FX 1169-M2	2NC	FX 1176-M2	2NO
12	<b>R</b>	FX 1256-M2	2NO	FX 1257-M2	2NO	FX 1269-M2	2NO	FX 1276-M2	2NC
13	<b>LV</b>	FX 1356-M2	2NC	FX 1357-M2	2NC	FX 1369-M2	2NC	FX 1376-M2	2NO
14	<b>LS</b>	FX 1456-M2	2NC	FX 1457-M2	2NC	FX 1469-M2	2NC	FX 1476-M2	2NO
15	<b>LS</b>	FX 1556-M2	2NO	FX 1557-M2	2NO	FX 1569-M2	2NO	FX 1576-M2	2NC
16	<b>LI</b>	FX 1656-M2	2NC	FX 1657-M2	2NC	FX 1669-M2	2NC	/	
18	<b>LA</b>	FX 1856-M2	1NO+1NC	FX 1857-M2	1NO+1NC	FX 1869-M2	1NO+1NC	FX 1876-M2	1NO+1NC
20	<b>L</b>	FX 2056-M2	1NO+2NC	FX 2057-M2	1NO+2NC	FX 2069-M2	1NO+2NC	FX 2076-M2	2NO+1NC
21	<b>L</b>	FX 2156-M2	3NC	FX 2157-M2	3NC	FX 2169-M2	3NC	FX 2176-M2	3NO
22	<b>L</b>	FX 2256-M2	2NO+1NC	FX 2257-M2	2NO+1NC	FX 2269-M2	2NO+1NC	FX 2276-M2	1NO+2NC
E1	<b>Λ</b>	FX E156-M2	1NO-1NC	FX E157-M2	1NO-1NC	FX E169-M2	1NO-1NC	/	
Max. speed	page 231 - type 1		page 231 - type 1		1.5 m/s		0.5 m/s		
Actuating force	0.06 Nm (0.25 Nm ⊕)		0.06 Nm (0.25 Nm ⊕)		0.06 Nm		initial 20 N - final 40 N		
Travel diagrams	page 232 - group 5		page 232 - group 5		page 232 - group 5		page 232 - group 7		

(1) Positive opening only with actuator set to max. See page 90.  
All values in the drawings are in mm

## FX series position switches with reset



The majority of switches can be equipped with a reset device (option W3) which enables the simultaneous actuation of actuator and contact block. The device is a module that is mounted between the body and the head of the switch that can be rotated independently from the head. The reset device has the following advantages:

- can be integrated into the majority of standard actuator heads;
- contact blocks with snap action are no more necessary because the tripping movement is executed by the reset device itself;
- can be rotated independently from the head ensuring maximum flexibility during installation;
- can be delivered with two different actuating forces: standard and increased for vibration applications;
- mechanical endurance: 1 million operating cycles.

Contact type  
**R** = snap action  
**L** = slow action

		With steel roller with self-lubrication or 316L stainless steel on request		With steel roller with self-lubrication or 316L stainless steel on request				
Contact block								
2	<b>R</b> FX 201-W3M2	2x(1NO-1NC)	FX 202-W3M2	2x(1NO-1NC)	FX 205-W3M2	2x(1NO-1NC)	FX 207-W3M2	2x(1NO-1NC)
6	<b>L</b> FX 601-W3M2	1NO+1NC	FX 602-W3M2	1NO+1NC	FX 605-W3M2	1NO+1NC	FX 607-W3M2	1NO+1NC
9	<b>L</b> FX 901-W3M2	2NC	FX 902-W3M2	2NC	FX 905-W3M2	2NC	FX 907-W3M2	2NC
10	<b>L</b> FX 1001-W3M2	2NO	FX 1002-W3M2	2NO	FX 1005-W3M2	2NO	FX 1007-W3M2	2NO
20	<b>L</b> FX 2001-W3M2	1NO+2NC	FX 2002-W3M2	1NO+2NC	FX 2005-W3M2	1NO+2NC	FX 2007-W3M2	1NO+2NC
21	<b>L</b> FX 2101-W3M2	3NC	FX 2102-W3M2	3NC	FX 2105-W3M2	3NC	FX 2107-W3M2	3NC
22	<b>L</b> FX 2201-W3M2	2NO+1NC	FX 2202-W3M2	2NO+1NC	FX 2205-W3M2	2NO+1NC	FX 2207-W3M2	2NO+1NC
Max. speed	page 231 - type 4		page 231 - type 3		page 231 - type 3		page 231 - type 3	
Actuating force	4.5 N (25 N ⊕)		4 N (25 N ⊕)		4 N (25 N ⊕)		2.5 N (25 N ⊕)	
Travel diagrams	page 233 - group 1		page 233 - group 2		page 233 - group 2		page 233 - group 3	

Contact type  
**R** = snap action  
**L** = slow action

		With Ø 12 mm steel roller with self-lubrication or 316L stainless steel on request		With Ø 20 mm steel roller with self-lubrication or 316L stainless steel on request		Other rollers available. See page 90		Other rollers available. See page 90	
Contact block									
2	<b>R</b> FX 215-W3M2	2x(1NO-1NC)	FX 230-W3M2	2x(1NO-1NC)	FX 231-W3M2	2x(1NO-1NC)	FX 251-W3M2	2x(1NO-1NC)	
6	<b>L</b> FX 615-W3M2	1NO+1NC	FX 630-W3M2	1NO+1NC	FX 631-W3M2	1NO+1NC	FX 651-W3M2	1NO+1NC	
9	<b>L</b> FX 915-W3M2	2NC	FX 930-W3M2	2NC	FX 931-W3M2	2NC	FX 951-W3M2	2NC	
10	<b>L</b> FX 1015-W3M2	2NO	FX 1030-W3M2	2NO	FX 1031-W3M2	2NO	FX 1051-W3M2	2NO	
20	<b>L</b> FX 2015-W3M2	1NO+2NC	FX 2030-W3M2	1NO+2NC	FX 2031-W3M2	1NO+2NC	FX 2051-W3M2	1NO+2NC	
21	<b>L</b> FX 2115-W3M2	3NC	FX 2130-W3M2	3NC	FX 2131-W3M2	3NC	FX 2151-W3M2	3NC	
22	<b>L</b> FX 2215-W3M2	2NO+1NC	FX 2230-W3M2	2NO+1NC	FX 2231-W3M2	2NO+1NC	FX 2251-W3M2	2NO+1NC	
Max. speed	page 231 - type 2		page 231 - type 1		page 231 - type 1		page 231 - type 1		
Actuating force	4.5 N (25 N ⊕)		0.07 Nm (0.25 Nm ⊖)		0.07 Nm (0.25 Nm ⊖)		0.07 Nm (0.25 Nm ⊖)		
Travel diagrams	page 233 - group 1		page 233 - group 4		page 233 - group 4		page 233 - group 4		



		Other rollers available. See page 90		Other rollers available. See page 90		Other rollers available. See page 90		Other rollers available. See page 90	
Contact type <b>R</b> = snap action <b>L</b> = slow action									
Contact block									
2	<b>R</b>	FX 252-W3M2	2x(1NO-1NC)	FX 254-W3M2	2x(1NO-1NC)	FX 256-W3M2	2x(1NO-1NC)	FX 257-W3M2	2x(1NO-1NC)
6	<b>L</b>	FX 652-W3M2	1NO+1NC	FX 654-W3M2	1NO+1NC	FX 656-W3M2	1NO+1NC	FX 657-W3M2	1NO+1NC
9	<b>L</b>	FX 952-W3M2	2NC	FX 954-W3M2	2NC	FX 956-W3M2	2NC	FX 957-W3M2	2NC
10	<b>L</b>	FX 1052-W3M2	2NO	FX 1054-W3M2	2NO	FX 1056-W3M2	2NO	FX 1057-W3M2	2NO
20	<b>L</b>	FX 2052-W3M2	1NO+2NC	FX 2054-W3M2	1NO+2NC	FX 2056-W3M2	1NO+2NC	FX 2057-W3M2	1NO+2NC
21	<b>L</b>	FX 2152-W3M2	3NC	FX 2154-W3M2	3NC	FX 2156-W3M2	3NC	FX 2157-W3M2	3NC
22	<b>L</b>	FX 2252-W3M2	2NO+1NC	FX 2254-W3M2	2NO+1NC	FX 2256-W3M2	2NO+1NC	FX 2257-W3M2	2NO+1NC
Max. speed		page 231 - type 1		page 231 - type 1		page 231 - type 1		page 231 - type 1	
Actuating force		0.07 Nm (0.25 Nm $\rightarrow$ )		0.07 Nm (0.25 Nm $\rightarrow$ )		0.07 Nm (0.25 Nm $\rightarrow$ )		0.07 Nm (0.25 Nm $\rightarrow$ )	
Travel diagrams		page 233 - group 4		page 233 - group 4		page 233 - group 4		page 233 - group 4	

### Increased actuating force

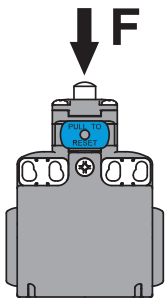

The switch can be delivered with increased actuating force (option W4). Ideal for vibration applications.

Actuators	Actuating force
01, 14, 15, 16	7 N
02, 05	6 N
07	3.5 N
30 ... 57	0.08 Nm

To order the switch with reset and increased actuating force, replace the -W3 option with -W4 in the order code.  
 Example: FX 601-W3M2  $\rightarrow$  FX 601-W4M2

## Position switches with swivelling lever without actuator

- Contact type
- R** = snap action
  - L** = slow action
  - LO** = slow action, make before break
  - LS** = slow action, shifted
  - LV** = slow action, shifted and spaced
  - LI** = slow action, independent
  - LA** = slow action, close
  - △** = electronic, PNP
- Contact block

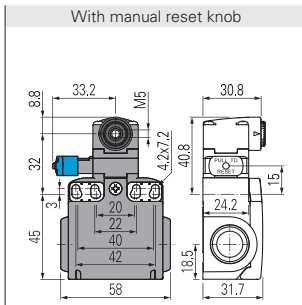
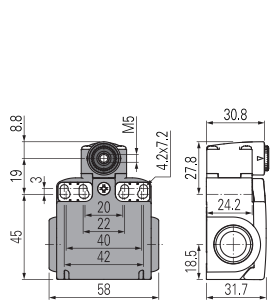

### IMPORTANT

**For safety applications:** join only switches and actuators marked with symbol next to the product code. For more information about safety applications see details on page 225.

2	<b>R</b>	FX 238-M2	2x(1NO-1NC)	FX 238-W3M2	2x(1NO-1NC)
5	<b>R</b>	FX 538-M2	1NO+1NC	/	/
6	<b>L</b>	FX 638-M2	1NO+1NC	FX 638-W3M2	1NO+1NC
7	<b>LO</b>	FX 738-M2	1NO+1NC	/	/
9	<b>L</b>	FX 938-M2	2NC	FX 938-W3M2	2NC
10	<b>L</b>	FX 1038-M2	2NO	FX 1038-W3M2	2NO
11	<b>R</b>	FX 1138-M2	2NC	/	/
12	<b>R</b>	FX 1238-M2	2NO	/	/
13	<b>LV</b>	FX 1338-M2	2NC	/	/
14	<b>LS</b>	FX 1438-M2	2NC	/	/
15	<b>LS</b>	FX 1538-M2	2NO	/	/
16	<b>LI</b>	FX 1638-M2	2NC	/	/
18	<b>LA</b>	FX 1838-M2	1NO+1NC	/	/
20	<b>L</b>	FX 2038-M2	1NO+2NC	FX 2038-W3M2	1NO+2NC
21	<b>L</b>	FX 2138-M2	3NC	FX 2138-W3M2	3NC
22	<b>L</b>	FX 2238-M2	2NO+1NC	FX 2238-W3M2	2NO+1NC
E1	<b>△</b>	FX E138-M2	1NO-1NC	/	/
Actuating force		0.06 Nm (0.25 Nm )		0.07 Nm (0.25 Nm )	
Travel diagrams		page 232 - group 5		page 233 - group 4	

## Separate actuators

**IMPORTANT:** These separate actuators can be used only with items of the FR, FM, FX, FZ and FK series.

Technopolymer roller Ø 18 mm	Technopolymer roller Ø 18 mm	Technopolymer roller Ø 14 mm	Technopolymer roller Ø 14 mm	Technopolymer roller Ø 20 mm	Technopolymer roller Ø 20 mm
VN A00KA	VN A00KB	VN A00KC	VN A00KD	VN A00KE	VN A00KF
Technopolymer roller Ø 20 mm	Technopolymer roller Ø 20 mm	Adjustable safety actuator with technopolymer roller	Adjustable square rod, 3x3x125 mm	Adjustable round rod Ø 3x125 mm	Adjustable glass fibre rod
VN A00KG	VN A00KH	VN A00KP	VN A00LB	VN A00LE	VN A00LH
Spring rod with plastic tip	Porcelain roller	Technopolymer roller Ø 14 mm	Technopolymer roller Ø 14 mm	Technopolymer roller Ø 20 mm	Adjustable safety lever with technopolymer roller Ø 20 mm
		With metallic parts in stainless steel			
VN A00LL	VN A00LP	VN A00KB-V38	VN A00KE-V38	VN A00KG-V38	VN A00KP-V38

All values in the drawings are in mm

Accessories See page 207

→ The 2D and 3D files are available at [www.pizzato.com](http://www.pizzato.com)

**Special separate actuators**
**IMPORTANT:** These separate actuators can be used only with items of the FR, FM, FX, FZ and FK series.

Steel rollers, Ø 20 mm, with self-lubrication					
VN A00KB-R24 (1)	VN A00KE-R24 (1)	VN A00KF-R24 (1)	VN A00KG-R24 (1)	VN A00KH-R24 (1)	VN A00KP-R24 (1)

**Note:** To order with 316L stainless steel roller: replace R24 with R41 in the order numbers.

Technopolymer rollers, Ø 35 mm					
VN A00KB-R25 (1)	VN A00KE-R25 (1)	VN A00KF-R25 (1)	VN A00KG-R25 (1)	VN A00KH-R25 (1)	VN A00KP-R25 (1)

Rubber rollers, Ø 40 mm					
VN A00KB-R5 (1)	VN A00KE-R5 (1)	VN A00KF-R5 (1)	VN A00KG-R5 (1)	VN A00KH-R5 (1)	VN A00KP-R5 (1)

Rubber rollers, Ø 50 mm				
VN A00KE-R26 (1)	VN A00KF-R26 (1)	VN A00KG-R26 (1)	VN A00KH-R26 (1)	VN A00KP-R26 (1)

Protruding rubber rollers, Ø 50 mm
VN A00KP-R27 (1)

(1) The actuator cannot be rotated to the inside because it will hit the switch head upon actuation.

(2) The position switch obtained by assembling switch FX •38-M2 (e.g. FX 538-M2, FX 638-M2, ...) with actuator VN A00LP will not present the same travel diagrams and actuating forces as switch FX •53-E0M2V9 (e.g. FX 553-E0M2V9, FX 653-E0M2V9, ...).

**Note:** To check the correspondence with previous lever codes, please consult the table "Changed article codes" on page 289. Example: VF LE30 -> VN A00KA.

Selection diagram

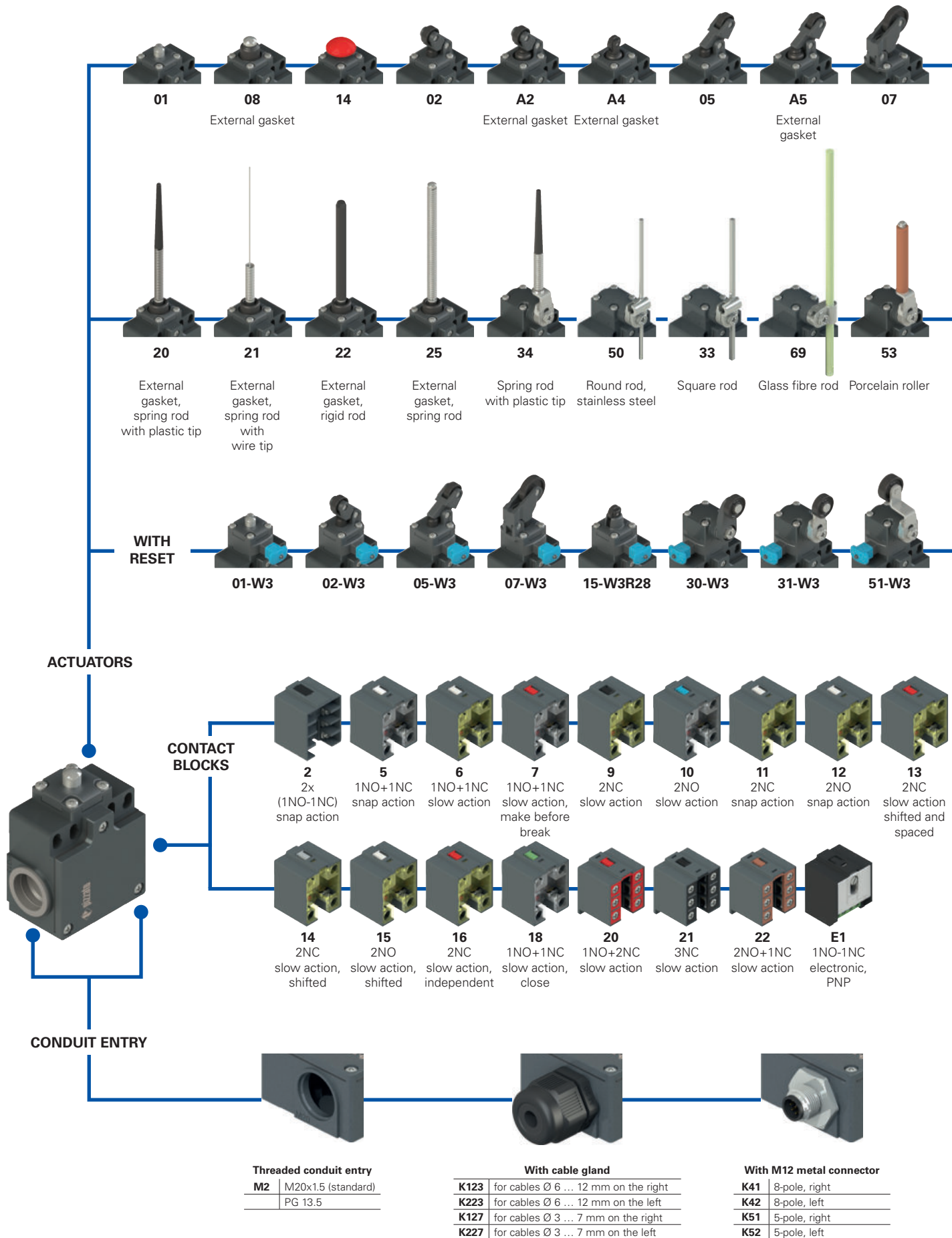

● Product options  
→ Sold separately as accessory



- A7**  
External gasket
- 15-R28**  
Steel roller, Ø 12 mm, with self-lubrication
- 16**  
Roller Ø 20 mm
- 12**
- 13**  
Steel roller, Ø 12 mm, with self-lubrication
- 76**  
Rope switch for signalling

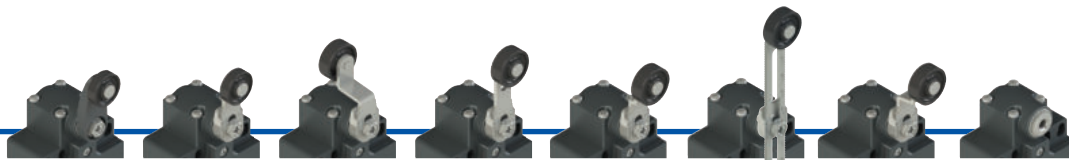

- 30**
- 31**
- 51**
- 52**
- 54**
- 56**  
Adjustable safety lever
- 57**
- 38**  
Without actuator



- 52-W3**
- 54-W3**
- 56-W3**
- 57-W3**
- 38-W3**  
Without actuator

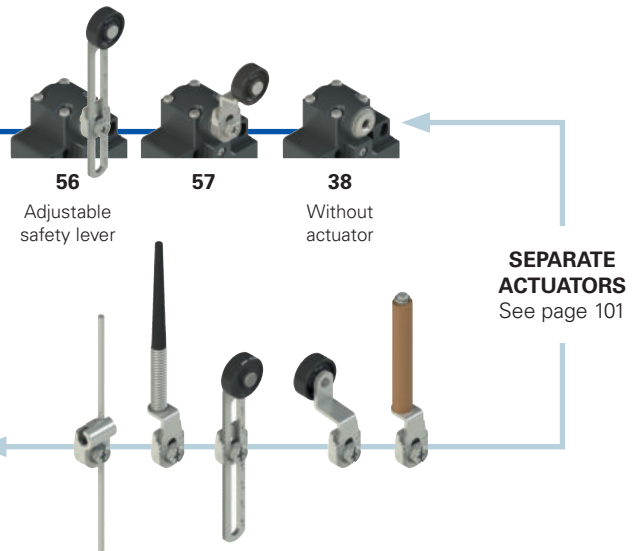

**SEPARATE ACTUATORS**  
See page 101

**Code structure** **Attention!** The feasibility of a code number does not mean the effective availability of a product. Please contact our sales office.

article
options
options

FZ 502-W3GM2K51R23T6

Ambient temperature	
	-25°C ... +80°C (standard)
<b>T6</b>	-40°C ... +80°C

Housing	
<b>FZ</b>	metal, two conduit entries
Contact block	
<b>5</b>	1NO+1NC, snap action
<b>6</b>	1NO+1NC, slow action
<b>7</b>	1NO+1NC, slow action, make before break
...	...
Actuators	
<b>01</b>	short plunger
<b>02</b>	roller lever
<b>05</b>	angled lever with roller
...	...
Reset	
	without reset (standard)
<b>W3</b>	simultaneous reset
<b>W4</b>	simultaneous reset, increased force

Contact type	
	silver contacts (standard)
<b>G</b>	silver contacts, 1 µm gold coating
<b>G1</b>	silver contacts, 2.5 µm gold coating (not for contact block 2, 20, 21, 22)

Pre-installed cable glands or connectors	
	no cable gland or connector (standard)
<b>K123</b>	cable gland for cables Ø 6 ... 12 mm on the right
<b>K51</b>	M12 metal connector, 5-pole, right

For the complete list of possible combinations please contact our technical department.

Threaded conduit entry	
<b>M2</b>	M20x1.5 (standard) PG 13.5

Rollers	
	standard roller
<b>R28</b>	Steel, with self-lubrication, Ø 12 mm (for actuators A4, 15)
<b>R44</b>	316L stainless steel, Ø 12 mm (for actuators A4, 13, 15)
<b>R23</b>	Steel, with self-lubrication, Ø 14 mm (for actuators A2, 02, A5, 05, 30, 31, 51, 52, 54, 55, 56, 57)
<b>R43</b>	316L stainless steel, Ø 14 mm (for actuators A2, 02, A5, 05, 30, 31, 51, 52, 54, 55, 56, 57)
<b>R24</b>	Steel, with self-lubrication, Ø 20 mm (for actuators 30, 31, 51, 52, 54, 55, 56, 57)
<b>R41</b>	316L stainless steel, Ø 20 mm (for actuators 30, 31, 51, 52, 54, 55, 56, 57)
<b>R36</b>	Steel, with self-lubrication, Ø 16 mm (for actuators 30, 31, 51, 52, 54, 55, 56, 57)
<b>R25</b>	technopolymer, Ø 35 mm (for actuators 30, 31, 51, 52, 54, 55, 56, 57)
<b>R5</b>	rubber, Ø 40 mm (for actuators 30, 31, 51, 52, 54, 55, 56, 57)
<b>R26</b>	rubber, Ø 50 mm (for actuators 51, 52, 54, 55, 56, 57)
<b>R27</b>	rubber, protruding, Ø 50 mm (for actuators 55, 56)



### Main features

- Metal housing, two conduit entries
- Protection degree IP67 and up to IP69K for actuators without external gasket
- 17 contact blocks available
- 44 actuators available
- Versions with M12 connector
- Versions with gold-plated silver contacts

### Quality marks:



IMQ approval:	EG610
UL approval:	E131787
CCC approval:	2021000305000101
EAC approval:	RU C-IT.YT03.B.00035/19

### Technical data

#### Housing

Metal housing, powder-coated

Two threaded conduit entries:

M20x1.5 (standard)

Protection degree with actuators A2, A4, A5, A7, 08, 20, 21, 22, 25:

IP67 acc. to EN 60529 (with cable gland of equal or higher protection degree)

Protection degree with actuators 01, 02, 05, 07, 12, 13, 14, 15, 15-R28, 16, 30, 31, 33, 34, 38, 50, 51, 52, 53, 54, 56, 57, 69, 76:

IP69K acc. to ISO 20653 (with cable gland of equal or higher protection degree)

#### General data

Ambient temperature:

-25°C ... +80°C (standard)

-40°C ... +80°C (T6 option)

Max. actuation frequency:

3600 operating cycles/hour

Mechanical endurance:

20 million operating cycles

Mounting position:

any

Safety parameter  $B_{10D}$ :

40,000,000 for NC contacts

Mechanical interlock, not coded:

type 1 acc. to EN ISO 14119

Tightening torques for installation:

see page 231

Wire cross-sections and

wire stripping lengths:

see page 249

#### In compliance with standards:

IEC 60947-5-1, EN 60947-5-1, EN 60947-1, IEC 60204-1, EN 60204-1, EN ISO 14119, EN ISO 12100, IEC 60529, EN 60529, EN IEC 63000, UL 508, CSA C22.2 No. 14.

#### Approvals:

IEC 60947-5-1, UL 508, CSA C22.2 No. 14, GB/T14048.5.

#### Compliance with the requirements of:

Low Voltage Directive 2014/35/EU, EMC Directive 2014/30/EU,

RoHS Directive 2011/65/EU.

#### Positive contact opening in conformity with standards:

IEC 60947-5-1, EN 60947-5-1.

### Installation for safety applications:

Use only switches marked with the  $\ominus$  symbol beside the product code. Always connect the safety circuit to the **NC contacts** (normally closed contacts: 11-12, 21-22 or 31-32) as required by **EN ISO 14119, paragraph 5.4** for specific interlock applications and **EN ISO 13849-2 tables D3** (well-tried components) and **D.8** (fault exclusions) for safety applications in general. Actuate the switch **at least up to the positive opening travel** shown in the travel diagrams on page 232. Actuate the switch **at least with the positive opening force**, reported in brackets below each article, next to the actuating force value.

**⚠ If not expressly indicated in this chapter, for correct installation and utilization of all articles see the instructions given on pages 227 to 242.**

	Electrical data	Utilization category
without connector	Thermal current ( $I_{th}$ ):	10 A
	Rated insulation voltage (U):	500 Vac 600 Vdc 400 Vac 500 Vdc (contact blocks 2, 11, 12, 20, 21, 22)
	Rated impulse withstand voltage ( $U_{imp}$ ):	6 kV 4 kV (contact blocks 20, 21, 22)
	Conditional short circuit current: Protection against short circuits: Pollution degree:	1000 A acc. to EN 60947-5-1 type aM fuse 10 A 500 V 3
with M12 connector, 5-pole	Thermal current ( $I_{th}$ ):	4 A
	Rated insulation voltage (U):	250 Vac 300 Vdc
	Protection against short circuits: Pollution degree:	type gG fuse 4 A 500 V 3
	Utilization category	Alternating current: AC15 (50÷60 Hz) Ue (V) 250 400 500 Ie (A) 6 4 1 Direct current: DC13 Ue (V) 24 125 250 Ie (A) 3 0.55 0.3
with M12 connector, 8-pole	Thermal current ( $I_{th}$ ):	2 A
	Rated insulation voltage (U):	30 Vac 36 Vdc
	Protection against short circuits: Pollution degree:	type gG fuse 2 A 500 V 3
	Utilization category	Alternating current: AC15 (50÷60 Hz) Ue (V) 24 Ie (A) 2 Direct current: DC13 Ue (V) 24 Ie (A) 2



### Features approved by IMQ

Rated insulation voltage (U<sub>i</sub>): 500 Vac  
 400 Vac (for contact blocks 2, 11, 12, 20, 21, 22, 28, 29, 30, 37, 33, 34)

Conventional free air thermal current (I<sub>th</sub>): 10 A

Protection against short circuits: type aM fuse 10 A 500 V

Rated impulse withstand voltage (U<sub>imp</sub>): 6 kV  
 4 kV (for contact blocks 20, 21, 22, 28, 29, 30, 33, 34)

Protection degree of the housing: IP67

MV terminals (screw terminals)

Pollution degree: 3

Utilization category: AC15

Operating voltage (U<sub>e</sub>): 400 Vac (50 Hz)

Operating current (I<sub>e</sub>): 3 A

Forms of the contact element: Za, Za+Za, X+X, Zb, Y+Y, Y+Y+X, Y+Y+Y, Y+X+X, Y, X.

Positive opening of contacts on contact blocks 5, 6, 7, 8, 9, 11, 13, 14, 16, 17, 18, 19, 20, 21, 22, 28, 29, 30, 33, 34, 37, 38, 39, 66.

In compliance with standards: EN 60947-1, EN 60947-5-1, fundamental requirements of the Low Voltage Directive 2014/35/EU.

Please contact our technical department for the list of approved products.

### Features approved by UL

Electrical Ratings: Q300 pilot duty (69 VA, 125-250 V dc)  
 A600 pilot duty (720 VA, 120-600 V ac)

Environmental Ratings: Types 1, 4X, 12, 13

For all contact blocks except 2 and 3 use 60 or 75°C copper (Cu) conductors, rigid or flexible, wire size 12, 14 AWG. Tightening torque for terminal screws of 7.1 lb in (0.8 Nm).

For contact blocks 2 and 3 use 60 or 75°C copper (Cu) conductors, rigid or flexible, wire size 14 AWG. Tightening torque for terminal screws of 12 lb in (1.4 Nm).

Please contact our technical department for the list of approved products.

### Wiring diagram for M12 connectors

Contact block 2 2x(1NO-1NC)	Contact block 5 1NO+1NC	Contact block 6 1NO+1NC	Contact block 7 1NO+1NC	Contact block 9 2NC	Contact block 10 2NO	Contact block 11 2NC	Contact block 12 2NO	Contact block 13 2NC
M12 connector, 8-pole	M12 connector, 5-pole	M12 connector, 5-pole	M12 connector, 5-pole	M12 connector, 5-pole	M12 connector, 5-pole	M12 connector, 5-pole	M12 connector, 5-pole	M12 connector, 5-pole
<b>Contacts Pin no.</b>	<b>Contacts Pin no.</b>	<b>Contacts Pin no.</b>	<b>Contacts Pin no.</b>	<b>Contacts Pin no.</b>	<b>Contacts Pin no.</b>	<b>Contacts Pin no.</b>	<b>Contacts Pin no.</b>	<b>Contacts Pin no.</b>
NO 3-4	NC 1-2	NC 1-2	NC 1-2	NC 1-2	NO 1-2	NC 1-2	NO 1-2	NC (1°) 1-2
NC 5-6	NO 3-4	NO 3-4	NO 3-4	NC 3-4	NO 3-4	NC 3-4	NO 3-4	NO (2°) 3-4
NC 7-8	ground 5	ground 5	ground 5	ground 5	ground 5	ground 5	ground 5	ground 5
NO 1-2								

Contact block 14 2NC	Contact block 15 2NO	Contact block 16 2NC	Contact block 18 1NO+1NC	Contact block 20 1NO+2NC	Contact block 21 3NC	Contact block 22 2NO+1NC	Contact block 33 1NO+1NC	Contact block 34 2NC
M12 connector, 5-pole	M12 connector, 5-pole	M12 connector, 5-pole	M12 connector, 5-pole	M12 connector, 8-pole	M12 connector, 8-pole	M12 connector, 8-pole	M12 connector, 5-pole	M12 connector, 5-pole
<b>Contacts Pin no.</b>	<b>Contacts Pin no.</b>	<b>Contacts Pin no.</b>	<b>Contacts Pin no.</b>	<b>Contacts Pin no.</b>	<b>Contacts Pin no.</b>	<b>Contacts Pin no.</b>	<b>Contacts Pin no.</b>	<b>Contacts Pin no.</b>
NC (1°) 1-2	NO (1°) 1-2	NC, lever to the right 1-2	NC 1-2	NC 3-4	NC 3-4	NC 3-4	NC 1-2	NC 1-2
NC (2°) 3-4	NO (2°) 3-4	NC, lever to the left 3-4	NO 3-4	NC 5-6	NC 5-6	NO 5-6	NO 3-4	NC 3-4
ground 5	ground 5	ground 5	ground 5	NO 7-8	NC 7-8	NO 7-8	ground 5	ground 5
				ground 1	ground 1	ground 1		

Contact block E1  
PNP



M12 connector, 5-pole

<b>Contacts Pin no.</b>
+ 1
- 3
NC 2
NO 4
ground 5

# FZ series position switches



- R** = snap action  
**L** = slow action  
**LO** = slow action, make before break  
**LS** = slow action, shifted  
**LV** = slow action, shifted and spaced  
**LI** = slow action, independent  
**LA** = slow action, close  
 = electronic, PNP

Contact block

		With steel roller with self-lubrication or 316L stainless steel on request	External gasket	External gasket
2 <b>R</b>	FZ 201-M2	2x(1NO-1NC)	FZ 202-M2	2x(1NO-1NC)
5 <b>R</b>	FZ 501-M2	1NO+1NC	FZ 502-M2	1NO+1NC
6 <b>L</b>	FZ 601-M2	1NO+1NC	FZ 602-M2	1NO+1NC
7 <b>LO</b>	FZ 701-M2	1NO+1NC	FZ 702-M2	1NO+1NC
9 <b>L</b>	FZ 901-M2	2NC	FZ 902-M2	2NC
10 <b>L</b>	FZ 1001-M2	2NO	FZ 1002-M2	2NO
11 <b>R</b>	FZ 1101-M2	2NC	FZ 1102-M2	2NC
12 <b>R</b>	FZ 1201-M2	2NO	FZ 1202-M2	2NO
13 <b>LV</b>	FZ 1301-M2	2NC	FZ 1302-M2	2NC
14 <b>LS</b>	FZ 1401-M2	2NC	FZ 1402-M2	2NC
15 <b>LS</b>	FZ 1501-M2	2NO	FZ 1502-M2	2NO
18 <b>LA</b>	FZ 1801-M2	1NO+1NC	FZ 1802-M2	1NO+1NC
20 <b>L</b>	FZ 2001-M2	1NO+2NC	FZ 2002-M2	1NO+2NC
21 <b>L</b>	FZ 2101-M2	3NC	FZ 2102-M2	3NC
22 <b>L</b>	FZ 2201-M2	2NO+1NC	FZ 2202-M2	2NO+1NC
E1 	FZ E101-M2	1NO-1NC	FZ E102-M2	1NO-1NC
Max. speed	page 231 - type 4		page 231 - type 3	
Actuating force	8 N (25 N  )		4.3 N (25 N  )	
Travel diagrams	page 232 - group 1		page 232 - group 2	

- R** = snap action  
**L** = slow action  
**LO** = slow action, make before break  
**LS** = slow action, shifted  
**LV** = slow action, shifted and spaced  
**LI** = slow action, independent  
**LA** = slow action, close  
 = electronic, PNP

Contact block

	With steel roller with self-lubrication or 316L stainless steel on request	External gasket	External gasket	External gasket
2 <b>R</b>	FZ 205-M2	2x(1NO-1NC)	FZ 2A5-M2	2x(1NO-1NC)
5 <b>R</b>	FZ 505-M2	1NO+1NC	FZ 5A5-M2	1NO+1NC
6 <b>L</b>	FZ 605-M2	1NO+1NC	FZ 6A5-M2	1NO+1NC
7 <b>LO</b>	FZ 705-M2	1NO+1NC	FZ 7A5-M2	1NO+1NC
9 <b>L</b>	FZ 905-M2	2NC	FZ 9A5-M2	2NC
10 <b>L</b>	FZ 1005-M2	2NO	FZ 10A5-M2	2NO
11 <b>R</b>	FZ 1105-M2	2NC	FZ 11A5-M2	2NC
12 <b>R</b>	FZ 1205-M2	2NO	FZ 12A5-M2	2NO
13 <b>LV</b>	FZ 1305-M2	2NC	FZ 13A5-M2	2NC
14 <b>LS</b>	FZ 1405-M2	2NC	FZ 14A5-M2	2NC
15 <b>LS</b>	FZ 1505-M2	2NO	FZ 15A5-M2	2NO
18 <b>LA</b>	FZ 1805-M2	1NO+1NC	FZ 18A5-M2	1NO+1NC
20 <b>L</b>	FZ 2005-M2	1NO+2NC	FZ 20A5-M2	1NO+2NC
21 <b>L</b>	FZ 2105-M2	3NC	FZ 21A5-M2	3NC
22 <b>L</b>	FZ 2205-M2	2NO+1NC	FZ 22A5-M2	2NO+1NC
E1 	FZ E105-M2	1NO-1NC	FZ E1A5-M2	1NO-1NC
Max. speed	page 231 - type 3		page 231 - type 3	
Actuating force	6 N (25 N  )		4 N (25 N  )	
Travel diagrams	page 232 - group 2		page 232 - group 3	

All values in the drawings are in mm

Accessories See page 207

→ The 2D and 3D files are available at [www.pizzato.com](http://www.pizzato.com)



		External gasket							
Contact type <b>R</b> = snap action <b>L</b> = slow action <b>LO</b> = slow action, make before break <b>LS</b> = slow action, shifted <b>LV</b> = slow action, shifted and spaced <b>LI</b> = slow action, independent <b>LA</b> = slow action, close <b>⚡</b> = electronic, PNP									
Contact block									
2	<b>R</b>	FZ 208-M2	2x(1NO-1NC)	FZ 212-M2	2x(1NO-1NC)	FZ 213-M2	2x(1NO-1NC)	FZ 214-M2	2x(1NO-1NC)
5	<b>R</b>	FZ 508-M2	⊕ 1NO+1NC	FZ 512-M2	⊕ 1NO+1NC	FZ 513-M2	⊕ 1NO+1NC	FZ 514-M2	⊕ 1NO+1NC
6	<b>L</b>	FZ 608-M2	⊕ 1NO+1NC	FZ 612-M2	⊕ 1NO+1NC	FZ 613-M2	⊕ 1NO+1NC	FZ 614-M2	⊕ 1NO+1NC
7	<b>LO</b>	FZ 708-M2	⊕ 1NO+1NC	FZ 712-M2	⊕ 1NO+1NC	FZ 713-M2	⊕ 1NO+1NC	FZ 714-M2	⊕ 1NO+1NC
9	<b>L</b>	FZ 908-M2	⊕ 2NC	FZ 912-M2	⊕ 2NC	FZ 913-M2	⊕ 2NC	FZ 914-M2	⊕ 2NC
10	<b>L</b>	FZ 1008-M2	2NO	FZ 1012-M2	2NO	FZ 1013-M2	2NO	FZ 1014-M2	2NO
11	<b>R</b>	FZ 1108-M2	⊕ 2NC	FZ 1112-M2	⊕ 2NC	FZ 1113-M2	⊕ 2NC	FZ 1114-M2	⊕ 2NC
12	<b>R</b>	FZ 1208-M2	2NO	FZ 1212-M2	2NO	FZ 1213-M2	2NO	FZ 1214-M2	2NO
13	<b>LV</b>	FZ 1308-M2	⊕ 2NC	FZ 1312-M2	⊕ 2NC	FZ 1313-M2	⊕ 2NC	FZ 1314-M2	⊕ 2NC
14	<b>LS</b>	FZ 1408-M2	⊕ 2NC	FZ 1412-M2	⊕ 2NC	FZ 1413-M2	⊕ 2NC	FZ 1414-M2	⊕ 2NC
15	<b>LS</b>	FZ 1508-M2	2NO	FZ 1512-M2	2NO	FZ 1513-M2	2NO	FZ 1514-M2	2NO
18	<b>LA</b>	FZ 1808-M2	⊕ 1NO+1NC	FZ 1812-M2	⊕ 1NO+1NC	FZ 1813-M2	⊕ 1NO+1NC	FZ 1814-M2	⊕ 1NO+1NC
20	<b>L</b>	FZ 2008-M2	⊕ 1NO+2NC	FZ 2012-M2	⊕ 1NO+2NC	FZ 2013-M2	⊕ 1NO+2NC	FZ 2014-M2	⊕ 1NO+2NC
21	<b>L</b>	FZ 2108-M2	⊕ 3NC	FZ 2112-M2	⊕ 3NC	FZ 2113-M2	⊕ 3NC	FZ 2114-M2	⊕ 3NC
22	<b>L</b>	FZ 2208-M2	⊕ 2NO+1NC	FZ 2212-M2	⊕ 2NO+1NC	FZ 2213-M2	⊕ 2NO+1NC	FZ 2214-M2	⊕ 2NO+1NC
E1	<b>⚡</b>	FZ E108-M2	1NO-1NC	FZ E112-M2	1NO-1NC	FZ E113-M2	1NO-1NC	FZ E114-M2	1NO-1NC
Max. speed	page 231 - type 4		page 231 - type 4		page 231 - type 2		page 231 - type 4		
Actuating force	8 N (25 N ⊕)		8 N (25 N ⊕)		8 N (25 N ⊕)		8 N (25 N ⊕)		
Travel diagrams	page 232 - group 1		page 232 - group 1		page 232 - group 1		page 232 - group 1		

		External gasket		External gasket		Spring rod		Spring rod	
Contact type <b>R</b> = snap action <b>L</b> = slow action <b>LO</b> = slow action, make before break <b>LS</b> = slow action, shifted <b>LV</b> = slow action, shifted and spaced <b>LI</b> = slow action, independent <b>LA</b> = slow action, close <b>⚡</b> = electronic, PNP									
Contact block									
2	<b>R</b>	FZ 215-M2R28	2x(1NO-1NC)	FZ 216-M2	2x(1NO-1NC)	FZ 220-M2	2x(1NO-1NC)	FZ 221-M2	2x(1NO-1NC)
5	<b>R</b>	FZ 515-M2R28	⊕ 1NO+1NC	FZ 516-M2	⊕ 1NO+1NC	FZ 520-M2	1NO+1NC	FZ 521-M2	1NO+1NC
6	<b>L</b>	FZ 615-M2R28	⊕ 1NO+1NC	FZ 616-M2	⊕ 1NO+1NC	/	/	/	/
7	<b>LO</b>	FZ 715-M2R28	⊕ 1NO+1NC	FZ 716-M2	⊕ 1NO+1NC	/	/	/	/
9	<b>L</b>	FZ 915-M2R28	⊕ 2NC	FZ 916-M2	⊕ 2NC	/	/	/	/
10	<b>L</b>	FZ 1015-M2R28	2NO	FZ 1016-M2	2NO	FZ 1020-M2	2NO	FZ 1021-M2	2NO
11	<b>R</b>	FZ 1115-M2R28	⊕ 2NC	FZ 1116-M2	⊕ 2NC	/	/	/	/
12	<b>R</b>	FZ 1215-M2R28	2NO	FZ 1216-M2	2NO	FZ 1220-M2	2NO	FZ 1221-M2	2NO
13	<b>LV</b>	FZ 1315-M2R28	⊕ 2NC	FZ 1316-M2	⊕ 2NC	/	/	/	/
14	<b>LS</b>	FZ 1415-M2R28	⊕ 2NC	FZ 1416-M2	⊕ 2NC	/	/	/	/
15	<b>LS</b>	FZ 1515-M2R28	2NO	FZ 1516-M2	2NO	/	/	/	/
18	<b>LA</b>	FZ 1815-M2R28	⊕ 1NO+1NC	FZ 1816-M2	⊕ 1NO+1NC	FZ 1820-M2	1NO+1NC	FZ 1821-M2	1NO+1NC
20	<b>L</b>	FZ 2015-M2R28	⊕ 1NO+2NC	FZ 2016-M2	⊕ 1NO+2NC	FZ 2020-M2	1NO+2NC	FZ 2021-M2	1NO+2NC
21	<b>L</b>	FZ 2115-M2R28	⊕ 3NC	FZ 2116-M2	⊕ 3NC	FZ 2120-M2	3NC	FZ 2121-M2	3NC
22	<b>L</b>	FZ 2215-M2R28	⊕ 2NO+1NC	FZ 2216-M2	⊕ 2NO+1NC	FZ 2220-M2	2NO+1NC	FZ 2221-M2	2NO+1NC
E1	<b>⚡</b>	FZ E115-M2R28	1NO-1NC	FZ E116-M2	1NO-1NC	FZ E120-M2	1NO-1NC	FZ E121-M2	1NO-1NC
Max. speed	page 231 - type 2		page 231 - type 2		1 m/s		1 m/s		
Actuating force	8 N (25 N ⊕)		8 N (25 N ⊕)		0.07 Nm		0.07 Nm		
Travel diagrams	page 232 - group 1		page 232 - group 1		page 232 - group 4		page 232 - group 4		

All values in the drawings are in mm

Accessories See page 207

 → The 2D and 3D files are available at [www.pizzato.com](http://www.pizzato.com)

# FZ series position switches

- Contact type
- R** = snap action
  - L** = slow action
  - LO** = slow action, make before break
  - LS** = slow action, shifted
  - LV** = slow action, shifted and spaced
  - LI** = slow action, independent
  - LA** = slow action, close
  - ⚡** = electronic, PNP

Contact block

	External gasket Rigid rod		External gasket Spring rod		With Ø 20 mm steel roller with self-lubrication or 316L stainless steel on request		Other rollers available. See page 102		
2	<b>R</b>	FZ 222-M2	2x(1NO-1NC)	FZ 225-M2	2x(1NO-1NC)	FZ 230-M2	2x(1NO-1NC)	FZ 231-M2	2x(1NO-1NC)
5	<b>R</b>	/		FZ 525-M2	1NO+1NC	FZ 530-M2	⊕ 1NO+1NC	FZ 531-M2	⊕ 1NO+1NC
6	<b>L</b>	/		/		FZ 630-M2	⊕ 1NO+1NC	FZ 631-M2	⊕ 1NO+1NC
7	<b>LO</b>	/		/		FZ 730-M2	⊕ 1NO+1NC	FZ 731-M2	⊕ 1NO+1NC
9	<b>L</b>	/		/		FZ 930-M2	⊕ 2NC	FZ 931-M2	⊕ 2NC
10	<b>L</b>	FZ 1022-M2	2NO	FZ 1025-M2	2NO	FZ 1030-M2	2NO	FZ 1031-M2	2NO
11	<b>R</b>	/		/		FZ 1130-M2	⊕ 2NC	FZ 1131-M2	⊕ 2NC
12	<b>R</b>	FZ 1222-M2	2NO	FZ 1225-M2	2NO	FZ 1230-M2	2NO	FZ 1231-M2	2NO
13	<b>LV</b>	/		/		FZ 1330-M2	⊕ 2NC	FZ 1331-M2	⊕ 2NC
14	<b>LS</b>	/		/		FZ 1430-M2	⊕ 2NC	FZ 1431-M2	⊕ 2NC
15	<b>LS</b>	/		/		FZ 1530-M2	2NO	FZ 1531-M2	2NO
16	<b>LI</b>	/		/		FZ 1630-M2	⊕ 2NC	FZ 1631-M2	⊕ 2NC
18	<b>LA</b>	FZ 1822-M2	⊕ 1NO+1NC	FZ 1825-M2	1NO+1NC	FZ 1830-M2	⊕ 1NO+1NC	FZ 1831-M2	⊕ 1NO+1NC
20	<b>L</b>	FZ 2022-M2	⊕ 1NO+2NC	FZ 2025-M2	1NO+2NC	FZ 2030-M2	⊕ 1NO+2NC	FZ 2031-M2	⊕ 1NO+2NC
21	<b>L</b>	FZ 2122-M2	⊕ 3NC	FZ 2125-M2	3NC	FZ 2130-M2	⊕ 3NC	FZ 2131-M2	⊕ 3NC
22	<b>L</b>	FZ 2222-M2	⊕ 2NO+1NC	FZ 2225-M2	2NO+1NC	FZ 2230-M2	⊕ 2NO+1NC	FZ 2231-M2	⊕ 2NO+1NC
E1	<b>⚡</b>	FZ E122-M2	1NO-1NC	FZ E125-M2	1NO-1NC	FZ E130-M2	1NO-1NC	FZ E131-M2	1NO-1NC
Max. speed	1 m/s		1 m/s		page 231 - type 1		page 231 - type 1		
Actuating force	0.12 Nm (0.25 Nm ⊕)		0.12 Nm		0.06 Nm (0.25 Nm ⊕)		0.06 Nm (0.25 Nm ⊕)		
Travel diagrams	page 232 - group 4		page 232 - group 4		page 232 - group 5		page 232 - group 5		

- Contact type
- R** = snap action
  - L** = slow action
  - LO** = slow action, make before break
  - LS** = slow action, shifted
  - LV** = slow action, shifted and spaced
  - LI** = slow action, independent
  - LA** = slow action, close
  - ⚡** = electronic, PNP

Contact block

	Square rod, 3x3 mm		Round rod, Ø 3 mm, stainless steel		Other rollers available. See page 102			
2	<b>R</b>	FZ 233-M2	2x(1NO-1NC)	FZ 234-M2	2x(1NO-1NC)	FZ 251-M2	2x(1NO-1NC)	
5	<b>R</b>	FZ 533-M2	1NO+1NC	FZ 534-M2	1NO+1NC	FZ 551-M2	⊕ 1NO+1NC	
6	<b>L</b>	FZ 633-M2	1NO+1NC	FZ 634-M2	1NO+1NC	FZ 651-M2	⊕ 1NO+1NC	
7	<b>LO</b>	FZ 733-M2	1NO+1NC	FZ 734-M2	1NO+1NC	FZ 751-M2	⊕ 1NO+1NC	
9	<b>L</b>	FZ 933-M2	2NC	FZ 934-M2	2NC	FZ 951-M2	⊕ 2NC	
10	<b>L</b>	FZ 1033-M2	2NO	FZ 1034-M2	2NO	FZ 1051-M2	2NO	
11	<b>R</b>	FZ 1133-M2	2NC	FZ 1134-M2	2NC	FZ 1151-M2	⊕ 2NC	
12	<b>R</b>	FZ 1233-M2	2NO	FZ 1234-M2	2NO	FZ 1251-M2	2NO	
13	<b>LV</b>	FZ 1333-M2	2NC	FZ 1334-M2	2NC	FZ 1351-M2	⊕ 2NC	
14	<b>LS</b>	FZ 1433-M2	2NC	FZ 1434-M2	2NC	FZ 1451-M2	⊕ 2NC	
15	<b>LS</b>	FZ 1533-M2	2NO	FZ 1534-M2	2NO	FZ 1551-M2	2NO	
16	<b>LI</b>	FZ 1633-M2	2NC	FZ 1634-M2	2NC	FZ 1651-M2	⊕ 2NC	
18	<b>LA</b>	FZ 1833-M2	1NO+1NC	FZ 1834-M2	1NO+1NC	FZ 1851-M2	⊕ 1NO+1NC	
20	<b>L</b>	FZ 2033-M2	1NO+2NC	FZ 2034-M2	1NO+2NC	FZ 2051-M2	⊕ 1NO+2NC	
21	<b>L</b>	FZ 2133-M2	3NC	FZ 2134-M2	3NC	FZ 2151-M2	⊕ 3NC	
22	<b>L</b>	FZ 2233-M2	2NO+1NC	FZ 2234-M2	2NO+1NC	FZ 2251-M2	⊕ 2NO+1NC	
E1	<b>⚡</b>	FZ E133-M2	1NO-1NC	FZ E134-M2	1NO-1NC	FZ E151-M2	1NO-1NC	
Max. speed	1.5 m/s		1.5 m/s		1.5 m/s		page 231 - type 1	
Actuating force	0.06 Nm		0.06 Nm		0.06 Nm		0.06 Nm (0.25 Nm ⊕)	
Travel diagrams	page 232 - group 5		page 232 - group 5		page 232 - group 5		page 232 - group 5	

All values in the drawings are in mm

Accessories See page 207

→ The 2D and 3D files are available at [www.pizzato.com](http://www.pizzato.com)



		Other rollers available. See page 102	Porcelain roller	Other rollers available. See page 102	Other rollers available. See page 102				
Contact type <b>R</b> = snap action <b>L</b> = slow action <b>LO</b> = slow action, make before break <b>LS</b> = slow action, shifted <b>LV</b> = slow action, shifted and spaced <b>LI</b> = slow action, independent <b>LA</b> = slow action, close <b>⌘</b> = electronic, PNP									
Contact block									
2	<b>R</b>	FZ 252-M2	2x(1NO-1NC)	FZ 253-E0M2	2x(1NO-1NC)	FZ 254-M2	2x(1NO-1NC)	FZ 256-M2	2x(1NO-1NC)
5	<b>R</b>	FZ 552-M2	⊕ 1NO+1NC	FZ 553-E0M2V9	⊕ 1NO+1NC	FZ 554-M2	⊕ 1NO+1NC	FZ 556-M2	⊕ 1NO+1NC
6	<b>L</b>	FZ 652-M2	⊕ 1NO+1NC	FZ 653-E0M2V9	⊕ 1NO+1NC	FZ 654-M2	⊕ 1NO+1NC	FZ 656-M2	⊕ 1NO+1NC
7	<b>LO</b>	FZ 752-M2	⊕ 1NO+1NC	FZ 753-E0M2V9	⊕ 1NO+1NC	FZ 754-M2	⊕ 1NO+1NC	FZ 756-M2	⊕ 1NO+1NC
9	<b>L</b>	FZ 952-M2	⊕ 2NC	FZ 953-E0M2V9	⊕ 2NC	FZ 954-M2	⊕ 2NC	FZ 956-M2	⊕ 2NC
10	<b>L</b>	FZ 1052-M2	2NO	FZ 1053-E0M2V9	2NO	FZ 1054-M2	2NO	FZ 1056-M2	2NO
11	<b>R</b>	FZ 1152-M2	⊕ 2NC	/	/	FZ 1154-M2	⊕ 2NC	FZ 1156-M2	⊕ 2NC
12	<b>R</b>	FZ 1252-M2	2NO	FZ 1253-E0M2V9	2NO	FZ 1254-M2	2NO	FZ 1256-M2	2NO
13	<b>LV</b>	FZ 1352-M2	⊕ 2NC	FZ 1353-E0M2V9	⊕ 2NC	FZ 1354-M2	⊕ 2NC	FZ 1356-M2	⊕ 2NC
14	<b>LS</b>	FZ 1452-M2	⊕ 2NC	FZ 1453-E0M2V9	⊕ 2NC	FZ 1454-M2	⊕ 2NC	FZ 1456-M2	⊕ 2NC
15	<b>LS</b>	FZ 1552-M2	2NO	FZ 1553-E0M2V9	2NO	FZ 1554-M2	2NO	FZ 1556-M2	2NO
16	<b>LI</b>	FZ 1652-M2	⊕ 2NC	/	/	FZ 1654-M2	⊕ 2NC	FZ 1656-M2	⊕ 2NC
18	<b>LA</b>	FZ 1852-M2	⊕ 1NO+1NC	FZ 1853-E0M2V9	⊕ 1NO+1NC	FZ 1854-M2	⊕ 1NO+1NC	FZ 1856-M2	⊕ 1NO+1NC
20	<b>L</b>	FZ 2052-M2	⊕ 1NO+2NC	FZ 2053-E0M2V9	⊕ 1NO+2NC	FZ 2054-M2	⊕ 1NO+2NC	FZ 2056-M2	⊕ 1NO+2NC
21	<b>L</b>	FZ 2152-M2	⊕ 3NC	FZ 2153-E0M2V9	⊕ 3NC	FZ 2154-M2	⊕ 3NC	FZ 2156-M2	⊕ 3NC
22	<b>L</b>	FZ 2252-M2	⊕ 2NO+1NC	FZ 2253-E0M2V9	⊕ 2NO+1NC	FZ 2254-M2	⊕ 2NO+1NC	FZ 2256-M2	⊕ 2NO+1NC
E1	<b>⌘</b>	FZ E152-M2	1NO-1NC	FZ E153-E0M2V9	1NO-1NC	FZ E154-M2	1NO-1NC	FZ E156-M2	1NO-1NC
Max. speed		page 231 - type 1		0.5 m/s		page 231 - type 1		page 231 - type 1	
Actuating force		0.06 Nm (0.25 Nm ⊕)		0.03 Nm (0.25 Nm ⊕)		0.06 Nm (0.25 Nm ⊕)		0.06 Nm (0.25 Nm ⊕)	
Travel diagrams		page 232 - group 5		page 232 - group 6		page 232 - group 5		page 232 - group 5	

		Other rollers available. See page 102	Glass fibre rod	Rope switch for signalling					
Contact type <b>R</b> = snap action <b>L</b> = slow action <b>LO</b> = slow action, make before break <b>LS</b> = slow action, shifted <b>LV</b> = slow action, shifted and spaced <b>LI</b> = slow action, independent <b>LA</b> = slow action, close <b>⌘</b> = electronic, PNP									
Contact block									
2	<b>R</b>	FZ 257-M2	2x(1NO-1NC)	FZ 269-M2	2x(1NO-1NC)	FZ 276-M2	2x(1NO-1NC)		
5	<b>R</b>	FZ 557-M2	⊕ 1NO+1NC	FZ 569-M2	1NO+1NC	FZ 576-M2	1NO+1NC		
6	<b>L</b>	FZ 657-M2	⊕ 1NO+1NC	FZ 669-M2	1NO+1NC	FZ 676-M2	1NO+1NC		
7	<b>LO</b>	FZ 757-M2	⊕ 1NO+1NC	FZ 769-M2	1NO+1NC	FZ 776-M2	1NO+1NC		
9	<b>L</b>	FZ 957-M2	⊕ 2NC	FZ 969-M2	2NC	FZ 976-M2	2NO		
10	<b>L</b>	FZ 1057-M2	2NO	FZ 1069-M2	2NO	FZ 1076-M2	2NC		
11	<b>R</b>	FZ 1157-M2	⊕ 2NC	FZ 1169-M2	2NC	FZ 1176-M2	2NO		
12	<b>R</b>	FZ 1257-M2	2NO	FZ 1269-M2	2NO	FZ 1276-M2	2NC		
13	<b>LV</b>	FZ 1357-M2	⊕ 2NC	FZ 1369-M2	2NC	FZ 1376-M2	2NO		
14	<b>LS</b>	FZ 1457-M2	⊕ 2NC	FZ 1469-M2	2NC	FZ 1476-M2	2NO		
15	<b>LS</b>	FZ 1557-M2	2NO	FZ 1569-M2	2NO	FZ 1576-M2	2NC		
16	<b>LI</b>	FZ 1657-M2	⊕ 2NC	FZ 1669-M2	2NC	/	/		
18	<b>LA</b>	FZ 1857-M2	⊕ 1NO+1NC	FZ 1869-M2	1NO+1NC	FZ 1876-M2	1NO+1NC		
20	<b>L</b>	FZ 2057-M2	⊕ 1NO+2NC	FZ 2069-M2	1NO+2NC	FZ 2076-M2	2NO+1NC		
21	<b>L</b>	FZ 2157-M2	⊕ 3NC	FZ 2169-M2	3NC	FZ 2176-M2	3NO		
22	<b>L</b>	FZ 2257-M2	⊕ 2NO+1NC	FZ 2269-M2	2NO+1NC	FZ 2276-M2	1NO+2NC		
E1	<b>⌘</b>	FZ E157-M2	1NO-1NC	FZ E169-M2	1NO-1NC	/	/		
Max. speed		page 231 - type 1		1.5 m/s		0.5 m/s			
Actuating force		0.06 Nm (0.25 Nm ⊕)		0.06 Nm		initial 20 N - final 40 N			
Travel diagrams		page 232 - group 5		page 232 - group 5		page 232 - group 7			

(1) Positive opening only with actuator set to max. See page 102.  
 All values in the drawings are in mm

## FZ series position switches with reset



The majority of switches can be equipped with a reset device (option W3) which enables the simultaneous actuation of actuator and contact block. The device is a module that is mounted between the body and the head of the switch that can be rotated independently from the head. The reset device has the following advantages:

- can be integrated into the majority of standard actuator heads;
- contact blocks with snap action are no more necessary because the tripping movement is executed by the reset device itself;
- can be rotated independently from the head ensuring maximum flexibility during installation;
- can be delivered with two different actuating forces: standard and increased for vibration applications;
- mechanical endurance: 1 million operating cycles.

Contact type  
**R** = snap action  
**L** = slow action

		With steel roller with self-lubrication or 316L stainless steel on request	With steel roller with self-lubrication or 316L stainless steel on request	With steel roller with self-lubrication or 316L stainless steel on request	With steel roller with self-lubrication or 316L stainless steel on request
Contact block					
2	<b>R</b>	FZ 201-W3M2	FZ 202-W3M2	FZ 205-W3M2	FZ 207-W3M2
		2x(1NO-1NC)	2x(1NO-1NC)	2x(1NO-1NC)	2x(1NO-1NC)
6	<b>L</b>	FZ 601-W3M2	FZ 602-W3M2	FZ 605-W3M2	FZ 607-W3M2
		1NO+1NC	1NO+1NC	1NO+1NC	1NO+1NC
9	<b>L</b>	FZ 901-W3M2	FZ 902-W3M2	FZ 905-W3M2	FZ 907-W3M2
		2NC	2NC	2NC	2NC
10	<b>L</b>	FZ 1001-W3M2	FZ 1002-W3M2	FZ 1005-W3M2	FZ 1007-W3M2
		2NO	2NO	2NO	2NO
20	<b>L</b>	FZ 2001-W3M2	FZ 2002-W3M2	FZ 2005-W3M2	FZ 2007-W3M2
		1NO+2NC	1NO+2NC	1NO+2NC	1NO+2NC
21	<b>L</b>	FZ 2101-W3M2	FZ 2102-W3M2	FZ 2105-W3M2	FZ 2107-W3M2
		3NC	3NC	3NC	3NC
22	<b>L</b>	FZ 2201-W3M2	FZ 2202-W3M2	FZ 2205-W3M2	FZ 2207-W3M2
		2NO+1NC	2NO+1NC	2NO+1NC	2NO+1NC
Max. speed		page 231 - type 4	page 231 - type 3	page 231 - type 3	page 231 - type 3
Actuating force		4.5 N (25 N $\ominus$ )	4 N (25 N $\ominus$ )	4 N (25 N $\ominus$ )	2.5 N (25 N $\ominus$ )
Travel diagrams		page 231 - group 1	page 231 - group 2	page 231 - group 2	page 231 - group 3

Contact type  
**R** = snap action  
**L** = slow action

		With $\varnothing$ 20 mm steel roller with self-lubrication or 316L stainless steel on request	Other rollers available. See page 102	Other rollers available. See page 102
Contact block				
2	<b>R</b>	FZ 215-W3M2R28	FZ 231-W3M2	FZ 251-W3M2
		2x(1NO-1NC)	2x(1NO-1NC)	2x(1NO-1NC)
6	<b>L</b>	FZ 615-W3M2R28	FZ 631-W3M2	FZ 651-W3M2
		1NO+1NC	1NO+1NC	1NO+1NC
9	<b>L</b>	FZ 915-W3M2R28	FZ 931-W3M2	FZ 951-W3M2
		2NC	2NC	2NC
10	<b>L</b>	FZ 1015-W3M2R28	FZ 1031-W3M2	FZ 1051-W3M2
		2NO	2NO	2NO
20	<b>L</b>	FZ 2015-W3M2R28	FZ 2031-W3M2	FZ 2051-W3M2
		1NO+2NC	1NO+2NC	1NO+2NC
21	<b>L</b>	FZ 2115-W3M2R28	FZ 2131-W3M2	FZ 2151-W3M2
		3NC	3NC	3NC
22	<b>L</b>	FZ 2215-W3M2R28	FZ 2231-W3M2	FZ 2251-W3M2
		2NO+1NC	2NO+1NC	2NO+1NC
Max. speed		page 231 - type 2	page 231 - type 1	page 231 - type 1
Actuating force		4.5 N (25 N $\ominus$ )	0.07 Nm (0.25 Nm $\ominus$ )	0.07 Nm (0.25 Nm $\ominus$ )
Travel diagrams		page 231 - group 1	page 231 - group 4	page 231 - group 4

Contact type	Other rollers available. See page 102		Other rollers available. See page 102		Other rollers available. See page 102		Other rollers available. See page 102		
	<b>R</b> = snap action <b>L</b> = slow action								
2	<b>R</b>	FZ 252-W3M2	2x(1NO-1NC)	FZ 254-W3M2	2x(1NO-1NC)	FZ 256-W3M2	2x(1NO-1NC)	FZ 257-W3M2	2x(1NO-1NC)
6	<b>L</b>	FZ 652-W3M2	1NO+1NC	FZ 654-W3M2	1NO+1NC	FZ 656-W3M2	1NO+1NC	FZ 657-W3M2	1NO+1NC
9	<b>L</b>	FZ 952-W3M2	2NC	FZ 954-W3M2	2NC	FZ 956-W3M2	2NC	FZ 957-W3M2	2NC
10	<b>L</b>	FZ 1052-W3M2	2NO	FZ 1054-W3M2	2NO	FZ 1056-W3M2	2NO	FZ 1057-W3M2	2NO
20	<b>L</b>	FZ 2052-W3M2	1NO+2NC	FZ 2054-W3M2	1NO+2NC	FZ 2056-W3M2	1NO+2NC	FZ 2057-W3M2	1NO+2NC
21	<b>L</b>	FZ 2152-W3M2	3NC	FZ 2154-W3M2	3NC	FZ 2156-W3M2	3NC	FZ 2157-W3M2	3NC
22	<b>L</b>	FZ 2252-W3M2	2NO+1NC	FZ 2254-W3M2	2NO+1NC	FZ 2256-W3M2	2NO+1NC	FZ 2257-W3M2	2NO+1NC
Max. speed		page 231 - type 1		page 231 - type 1		page 231 - type 1		page 231 - type 1	
Actuating force		0.07 Nm (0.25 Nm $\rightarrow$ )		0.07 Nm (0.25 Nm $\rightarrow$ )		0.07 Nm (0.25 Nm $\rightarrow$ )		0.07 Nm (0.25 Nm $\rightarrow$ )	
Travel diagrams		page 231 - group 4		page 231 - group 4		page 231 - group 4		page 231 - group 4	

### Increased actuating force

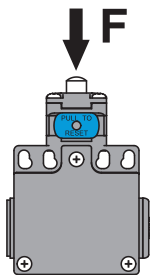

The switch can be delivered with increased actuating force (option W4). Ideal for vibration applications.

Actuators	Actuating force
01, 14, 15, 16	7 N
02, 05	6 N
07	3.5 N
30 ... 57	0.08 Nm

To order the switch with reset and increased actuating force, replace the -W3 option with -W4 in the order code.

Example: FZ 601-**W3**M2  $\rightarrow$  FZ 601-**W4**M2

## Position switches with swivelling lever without actuator

- Contact type
- R** = snap action
  - L** = slow action
  - LO** = slow action, make before break
  - LS** = slow action, shifted
  - LV** = slow action, shifted and spaced
  - LI** = slow action, independent
  - LA** = slow action, close
  - ⏏** = electronic, PNP
- Contact block

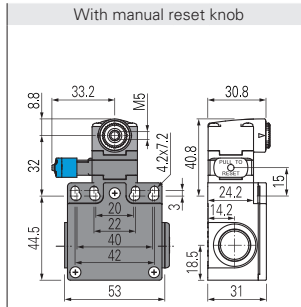
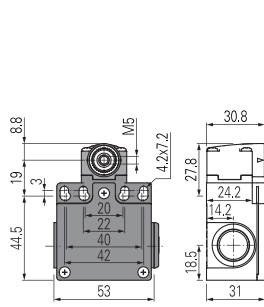

### IMPORTANT

**For safety applications:** join only switches and actuators marked with symbol next to the product code. For more information about safety applications see details on page 225.

2	<b>R</b>	FZ 238-M2	2x(1NO-1NC)	FZ 238-W3M2	2x(1NO-1NC)
5	<b>R</b>	FZ 538-M2	⊕ 1NO+1NC	/	/
6	<b>L</b>	FZ 638-M2	⊕ 1NO+1NC	FZ 638-W3M2	⊕ 1NO+1NC
7	<b>LO</b>	FZ 738-M2	⊕ 1NO+1NC	/	/
9	<b>L</b>	FZ 938-M2	⊕ 2NC	FZ 938-W3M2	⊕ 2NC
10	<b>L</b>	FZ 1038-M2	2NO	FZ 1038-W3M2	2NO
11	<b>R</b>	FZ 1138-M2	⊕ 2NC	/	/
12	<b>R</b>	FZ 1238-M2	2NO	/	/
13	<b>LV</b>	FZ 1338-M2	⊕ 2NC	/	/
14	<b>LS</b>	FZ 1438-M2	⊕ 2NC	/	/
15	<b>LS</b>	FZ 1538-M2	2NO	/	/
16	<b>LI</b>	FZ 1638-M2	⊕ 2NC	/	/
18	<b>LA</b>	FZ 1838-M2	⊕ 1NO+1NC	/	/
20	<b>L</b>	FZ 2038-M2	⊕ 1NO+2NC	FZ 2038-W3M2	⊕ 1NO+2NC
21	<b>L</b>	FZ 2138-M2	⊕ 3NC	FZ 2138-W3M2	⊕ 3NC
22	<b>L</b>	FZ 2238-M2	⊕ 2NO+1NC	FZ 2238-W3M2	⊕ 2NO+1NC
E1	<b>⏏</b>	FZ E138-M2	1NO-1NC	/	/
Actuating force		0.06 Nm (0.25 Nm ⊕)		0.07 Nm (0.25 Nm ⊕)	
Travel diagrams		page 232 - group 5		page 231 - group 4	

## Separate actuators

**IMPORTANT:** These separate actuators can be used only with items of the FR, FM, FX, FZ and FK series.

Technopolymer roller Ø 18 mm	Technopolymer roller Ø 18 mm	Technopolymer roller Ø 14 mm	Technopolymer roller Ø 14 mm	Technopolymer roller Ø 20 mm	Technopolymer roller Ø 20 mm
VN A00KA ⊕	VN A00KB ⊕	VN A00KC ⊕	VN A00KD ⊕	VN A00KE ⊕	VN A00KF ⊕
Technopolymer roller Ø 20 mm	Technopolymer roller Ø 20 mm	Adjustable safety actuator with technopolymer roller	Adjustable square rod, 3x3x125 mm	Adjustable round rod Ø 3x125 mm	Adjustable glass fibre rod
VN A00KG ⊕	VN A00KH ⊕	VN A00KP ⊕	VN A00LB	VN A00LE	VN A00LH
Spring rod with plastic tip	Porcelain roller	Technopolymer roller Ø 14 mm	Technopolymer roller Ø 14 mm	Technopolymer roller Ø 20 mm	Adjustable safety lever with technopolymer roller Ø 20 mm
		With metallic parts in stainless steel			
VN A00LL	VN A00LP ⊕ (2)	VN A00KB-V38 ⊕	VN A00KE-V38 ⊕	VN A00KG-V38 ⊕	VN A00KP-V38 ⊕

All values in the drawings are in mm

Accessories See page 207

→ The 2D and 3D files are available at [www.pizzato.com](http://www.pizzato.com)



### Special separate actuators

**IMPORTANT:** These separate actuators can be used only with items of the FR, FM, FX, FZ and FK series.

Steel rollers, Ø 20 mm, with self-lubrication					
VN A00KB-R24 (1)	VN A00KE-R24 (1)	VN A00KF-R24 (1)	VN A00KG-R24 (1)	VN A00KH-R24 (1)	VN A00KP-R24 (1)

**Note:** To order with 316L stainless steel roller: replace R24 with R41 in the order numbers.

Technopolymer rollers, Ø 35 mm					
VN A00KB-R25 (1)	VN A00KE-R25 (1)	VN A00KF-R25 (1)	VN A00KG-R25 (1)	VN A00KH-R25 (1)	VN A00KP-R25 (1)

Rubber rollers, Ø 40 mm					
VN A00KB-R5 (1)	VN A00KE-R5 (1)	VN A00KF-R5 (1)	VN A00KG-R5 (1)	VN A00KH-R5 (1)	VN A00KP-R5 (1)

Rubber rollers, Ø 50 mm				
VN A00KE-R26 (1)	VN A00KF-R26 (1)	VN A00KG-R26 (1)	VN A00KH-R26 (1)	VN A00KP-R26 (1)

Protruding rubber rollers, Ø 50 mm
VN A00KP-R27 (1)

- (1) The actuator cannot be rotated to the inside because it will hit the switch head upon actuation.

- (2) The position switch obtained by assembling switch FZ •38-M2 (e.g. FZ 538-M2, FZ 638-M2, ...) with actuator VN A00LP will not present the same travel diagrams and actuating forces as switch FZ •53-E0M2V9 (e.g. FZ 553-E0M2V9, FZ 653-E0M2V9, ...).

**Note:** To check the correspondence with previous lever codes, please consult the table "Changed article codes" on page 289. Example: VF LE30 -> VN A00KA.

Selection diagram

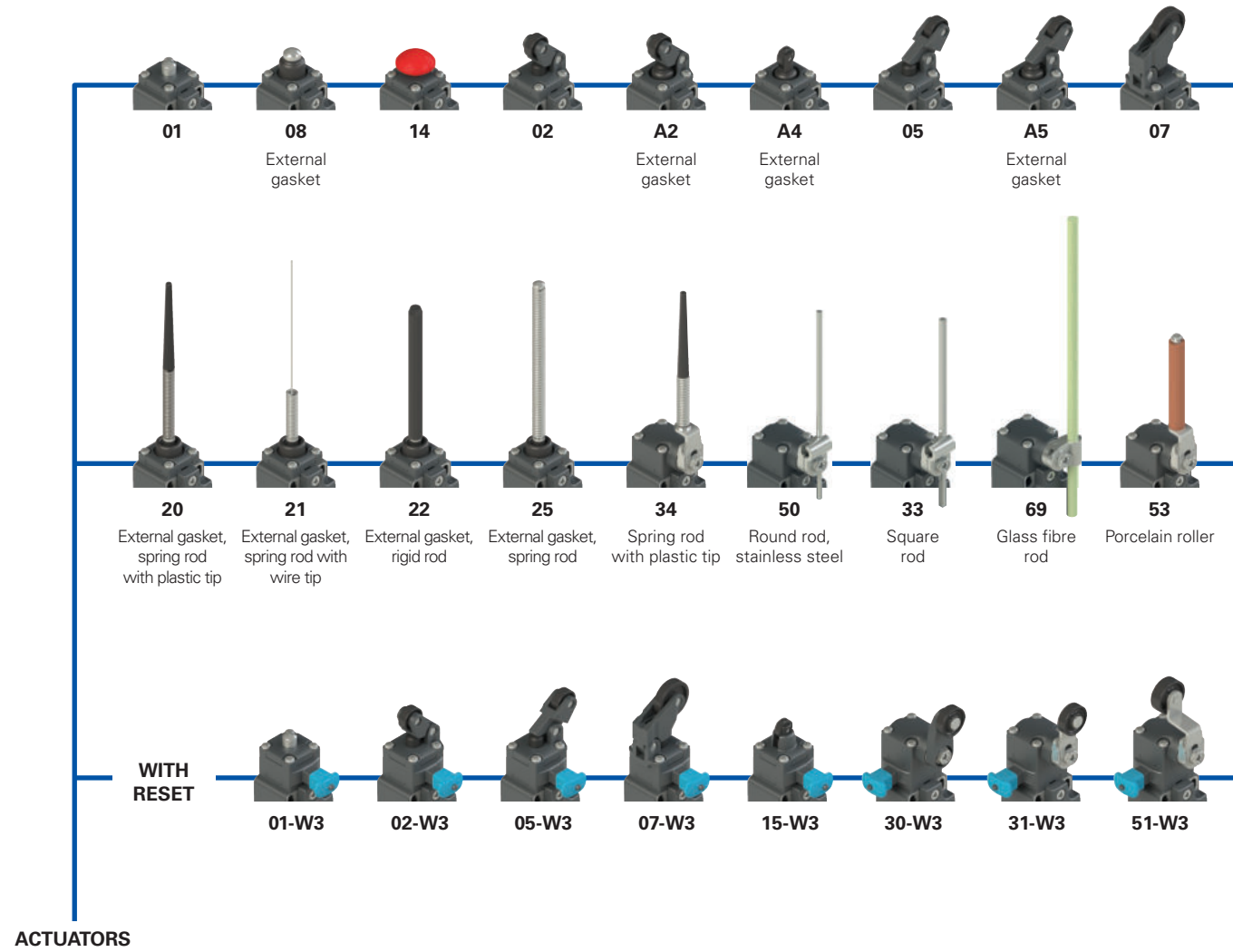

ACTUATORS



CONTACT BLOCKS

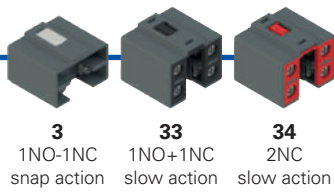

CONDUIT ENTRY

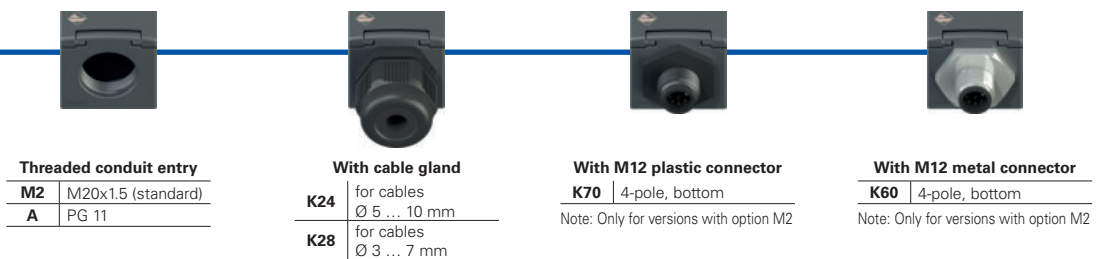

- Product options
- ➔ Sold separately as accessory



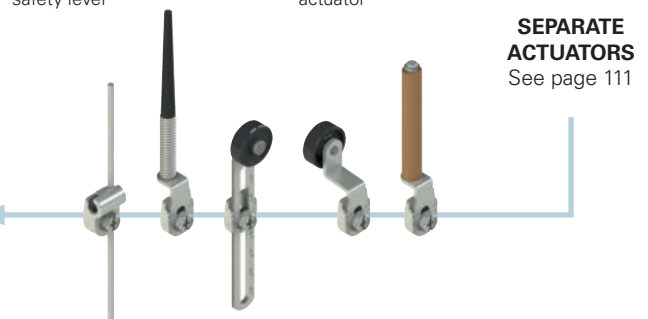
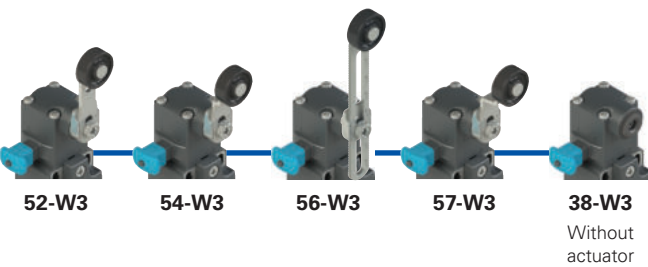
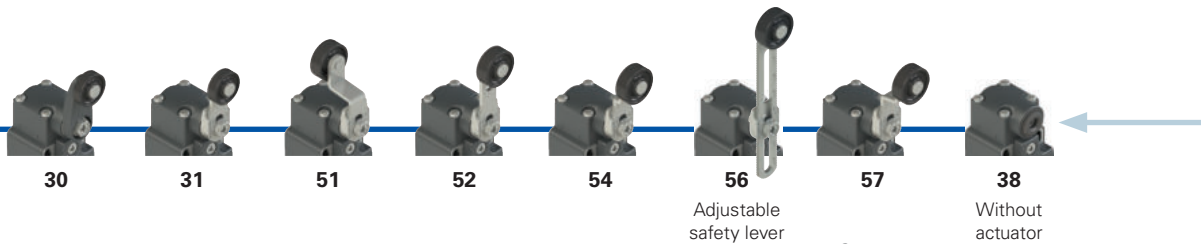
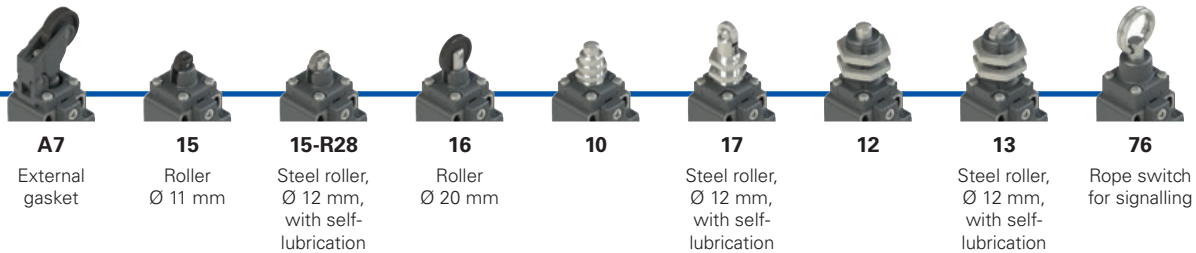

### Code structure

**Attention!** The feasibility of a code number does not mean the effective availability of a product. Please contact our sales office.

article options options  
**FK 302-W3XGM2K24R23T6**

#### Ambient temperature

-25°C ... +80°C (standard)

**T6** -40°C ... +80°C

#### Housing

**FK** technopolymer, one conduit entry

#### Contact block

- 3** 1NO+1NC, snap action
- 33** 1NO+1NC, slow action
- 34** 2NC, slow action

#### Actuators

- 01** short plunger
- 02** roller lever
- 05** angled lever with roller
- ... ..

#### Reset

- without reset (standard)
- W3** simultaneous reset
- W4** simultaneous reset, increased force

#### External metallic parts

- zinc-plated steel (standard)
- X** stainless steel

#### Contact type

- silver contacts (standard)
- G** silver contacts, 1 µm gold coating

#### Pre-installed cable glands or connectors

no cable gland or connector (standard)

**K24** cable gland for cables Ø 5 ... 10 mm

**K70** M12 plastic connector, 4-pole

For the complete list of possible combinations please contact our technical department.

#### Rollers

- standard roller
- R28** Steel, with self-lubrication, Ø 12 mm (for actuators A4, 15)
- R44** 316L stainless steel, Ø 12 mm (for actuators A4, 13, 15, 17)
- R23** Steel, with self-lubrication, Ø 14 mm (for actuators A2, 02, A5, 05, 30, 31, 51, 52, 54, 55, 56, 57)
- R43** 316L stainless steel, Ø 14 mm (for actuators A2, 02, A5, 05, 30, 31, 51, 52, 54, 55, 56, 57)
- R24** Steel, with self-lubrication, Ø 20 mm (for actuators 30, 31, 51, 52, 54, 55, 56, 57)
- R41** 316L stainless steel, Ø 20 mm (for actuators 30, 31, 51, 52, 54, 55, 56, 57)
- R36** Steel, with self-lubrication, Ø 16 mm (for actuators 30, 31, 51, 52, 54, 55, 56, 57)
- R25** technopolymer, Ø 35 mm (for actuators 30, 31, 51, 52, 54, 55, 56, 57)
- R5** rubber, Ø 40 mm (for actuators 30, 31, 51, 52, 54, 55, 56, 57)
- R26** rubber, Ø 50 mm (for actuators 51, 52, 54, 55, 56, 57)
- R27** rubber, protruding, Ø 50 mm (for actuators 55, 56)

#### Threaded conduit entry

- M2** M20x1.5 (standard)
- PG 11



### Main features

- Technopolymer housing, one conduit entry
- Hinged cover, fixed with single captive screw
- Metal plates on mounting holes of the housing
- Protection degree IP67 and up to IP69K for actuators without external gasket
- 3 contact blocks available
- 47 actuators available
- Versions with external parts in stainless steel
- Versions with gold-plated silver contacts

### Quality marks:



IMQ approval:	EG610
UL approval:	E131787
CCC approval:	2021000305000101
EAC approval:	RU C-IT.YT03.B.00035/19

### Installation for safety applications:

Use only switches marked with the  $\ominus$  symbol beside the product code. Always connect the safety circuit to the **NC contacts** (normally closed contacts: 11-12, 21-22 or 31-32) as required by **EN ISO 14119, paragraph 5.4** for specific interlock applications and **EN ISO 13849-2 tables D3** (well-trieed components) and **D.8** (fault exclusions) for safety applications in general. Actuate the switch **at least up to the positive opening travel** shown in the travel diagrams on page 232. Actuate the switch **at least with the positive opening force**, reported in brackets below each article, next to the actuating force value.

**⚠ If not expressly indicated in this chapter, for correct installation and utilization of all articles see the instructions given on pages 227 to 242.**

## Technical data

### Housing

Housing made of glass fibre reinforced technopolymer, self-extinguishing, shock-proof and with double insulation:  $\square$

One threaded conduit entry:	M16x1.5 (standard)
Protection degree with actuators A1, A2, A4, A5, A7, 08, 20, 21, 22, 25:	IP67 acc. to EN 60529 (with cable gland of equal or higher protection degree)
Protection degree with actuators 01, 02, 05, 07, 10, 12, 13, 14, 15, 15-R28, 16, 17, 30, 31, 33, 34, 38, 50, 51, 52, 53, 54, 55, 56, 57, 69, 76:	IP69K acc. to ISO 20653 (with cable gland of equal or higher protection degree)

### General data

Ambient temperature:	-25°C ... +80°C (standard) -40°C ... +80°C (T6 option)
Max. actuation frequency:	3600 operating cycles/hour
Mechanical endurance:	20 million operating cycles
Mounting position:	any
Safety parameter B <sub>10D</sub> :	40,000,000 for NC contacts
Mechanical interlock, not coded:	type 1 acc. to EN ISO 14119
Tightening torques for installation:	see page 231
Wire cross-sections and wire stripping lengths:	see page 249

### In compliance with standards:

IEC 60947-5-1, EN 60947-5-1, EN 60947-1, IEC 60204-1, EN 60204-1, EN ISO 14119, EN ISO 12100, IEC 60529, EN 60529, EN IEC 63000, UL 508, CSA C22.2 No. 14.

### Approvals:

IEC 60947-5-1, UL 508, CSA C22.2 No. 14, GB/T14048.5.

### Compliance with the requirements of:

Low Voltage Directive 2014/35/EU, EMC Directive 2014/30/EU, RoHS Directive 2011/65/EU.

### Positive contact opening in conformity with standards:

IEC 60947-5-1, EN 60947-5-1.

### Electrical data

### Utilization category

	without connector	with M12 connector, 4-pole	
Thermal current (I <sub>th</sub> ):	10 A	4 A	Alternating current: AC15 (50÷60 Hz)
Rated insulation voltage (U <sub>i</sub> ):	500 Vac 600 Vdc 400 Vac 500 Vdc (contact blocks 33, 34)	250 Vac 300 Vdc	U <sub>e</sub> (V) 250 400 500
Rated impulse withstand voltage (U <sub>imp</sub> ):	6 kV 4 kV (contact block 33, 34)	Protection against short circuits: type gG fuse 4 A 500 V	I <sub>e</sub> (A) 6 4 1
Conditional short circuit current:	1000 A acc. to EN 60947-5-1	Pollution degree:	Direct current: DC13
Protection against short circuits:	type aM fuse 10 A 500 V		U <sub>e</sub> (V) 24 125 250
Pollution degree:	3		I <sub>e</sub> (A) 3 0.55 0.3
			Alternating current: AC15 (50÷60 Hz)
			U <sub>e</sub> (V) 24 120 250
			I <sub>e</sub> (A) 4 4 4
			Direct current: DC13
			U <sub>e</sub> (V) 24 125 250
			I <sub>e</sub> (A) 3 0.55 0.3

### Features approved by IMQ

Rated insulation voltage ( $U_i$ ): 500 Vac  
 400 Vac (for contact blocks 33, 34)

Conventional free air thermal current ( $I_{th}$ ): 10 A

Protection against short circuits: type aM fuse 10 A 500 V

Rated impulse withstand voltage ( $U_{imp}$ ): 6 kV  
 4 kV (for contact blocks 33, 34)

Protection degree of the housing: IP67

MV terminals (screw terminals)

Pollution degree: 3

Utilization category: AC15

Operating voltage ( $U_o$ ): 400 Vac (50 Hz)

Operating current ( $I_o$ ): 3 A

Forms of the contact element: Za, Zb, Y+Y, Y.

Positive opening of contacts on contact blocks 33, 34.

In compliance with standards: EN 60947-1, EN 60947-5-1, fundamental requirements of the Low Voltage Directive 2014/35/EU.

**Please contact our technical department for the list of approved products.**

### Features approved by UL

Electrical Ratings: Q300 pilot duty (69 VA, 125-250 V dc)  
 A600 pilot duty (720 VA, 120-600 V ac)

Environmental Ratings: Types 1, 4X, 12, 13

For all contact blocks except 2 and 3 use 60 or 75°C copper (Cu) conductors, rigid or flexible, wire size 12, 14 AWG. Tightening torque for terminal screws of 7.1 lb in (0.8 Nm).

For contact blocks 2 and 3 use 60 or 75°C copper (Cu) conductors, rigid or flexible, wire size 14 AWG. Tightening torque for terminal screws of 12 lb in (1.4 Nm).

The hub is to be connected to the conduit before the hub is connected to the enclosure.

**Please contact our technical department for the list of approved products.**

### Wiring diagram for M12 connectors

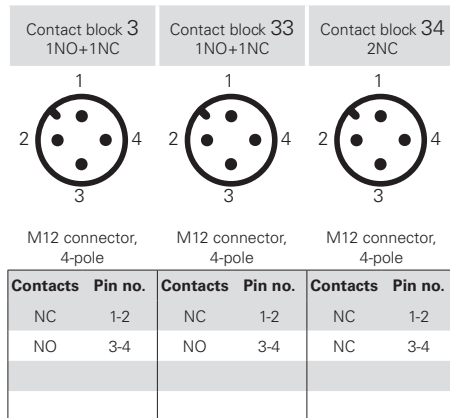

# FK series position switches

Contact type  
**R** = snap action  
**L** = slow action

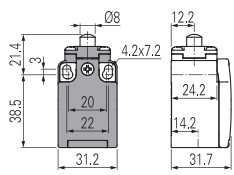
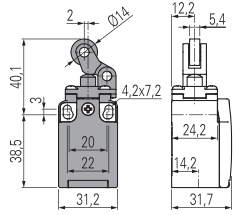
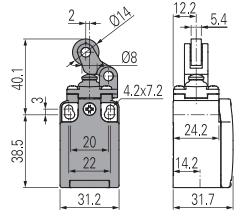
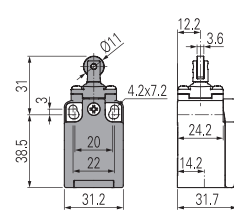
		With steel roller with self-lubrication or 316L stainless steel on request	External gasket With steel roller with self-lubrication or 316L stainless steel on request	External gasket With Ø 12 mm steel roller with self-lubrication or 316L stainless steel on request
Contact block				
3 <b>R</b>	FK 301-M2 1NO-1NC	FK 302-M2 1NO-1NC	FK 3A2-M2 1NO-1NC	FK 3A4-M2 1NO-1NC
33 <b>L</b>	FK 3301-M2 $\odot$ 1NO+1NC	FK 3302-M2 $\odot$ 1NO+1NC	FK 33A2-M2 $\odot$ 1NO+1NC	FK 33A4-M2 $\odot$ 1NO+1NC
34 <b>L</b>	FK 3401-M2 $\odot$ 2NC	FK 3402-M2 $\odot$ 2NC	FK 34A2-M2 $\odot$ 2NC	FK 34A4-M2 $\odot$ 2NC
Max. speed	page 231 - type 4	page 231 - type 3	page 231 - type 3	page 231 - type 5
Actuating force	5 N (25 N $\odot$ )	4 N (25 N $\odot$ )	4.3 N (25 N $\odot$ )	4.3 N (25 N $\odot$ )
Travel diagrams	page 232 - group 1	page 232 - group 2	page 232 - group 2	page 232 - group 1

Contact type  
**R** = snap action  
**L** = slow action

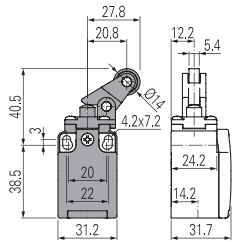
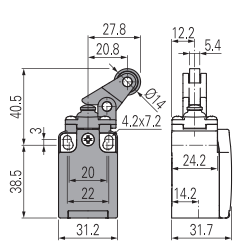
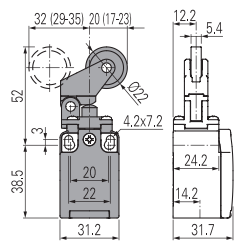
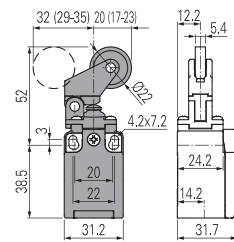
	With steel roller with self-lubrication or 316L stainless steel on request	External gasket With steel roller with self-lubrication or 316L stainless steel on request	External gasket	External gasket
Contact block				
3 <b>R</b>	FK 305-M2 1NO-1NC	FK 3A5-M2 1NO-1NC	FK 307-M2 1NO-1NC	FK 3A7-M2 1NO-1NC
33 <b>L</b>	FK 3305-M2 $\odot$ 1NO+1NC	FK 33A5-M2 $\odot$ 1NO+1NC	FK 3307-M2 $\odot$ 1NO+1NC	FK 33A7-M2 $\odot$ 1NO+1NC
34 <b>L</b>	FK 3405-M2 $\odot$ 2NC	FK 34A5-M2 $\odot$ 2NC	FK 3407-M2 $\odot$ 2NC	FK 34A7-M2 $\odot$ 2NC
Max. speed	page 231 - type 3	page 231 - type 3	page 231 - type 3	page 231 - type 3
Actuating force	4 N (25 N $\odot$ )	4.3 N (25 N $\odot$ )	4 N (25 N $\odot$ )	3 N (25 N $\odot$ )
Travel diagrams	page 232 - group 2	page 232 - group 2	page 232 - group 3	page 232 - group 3

Contact type  
**R** = snap action  
**L** = slow action

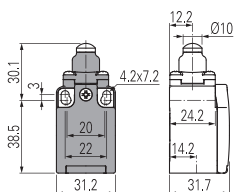
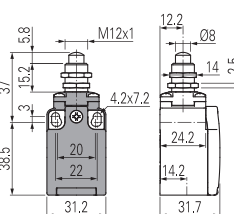
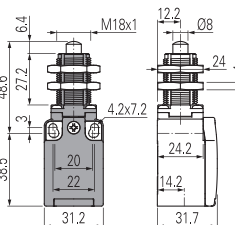
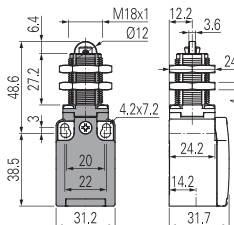
	External gasket	Secured only by means of threaded head in vertical position	External gasket	External gasket
Contact block				
3 <b>R</b>	FK 308-M2 1NO-1NC	FK 310-M2 1NO-1NC	FK 312-M2 1NO-1NC	FK 313-M2 1NO-1NC
33 <b>L</b>	FK 3308-M2 $\odot$ 1NO+1NC	FK 3310-M2 $\odot$ 1NO+1NC	FK 3312-M2 $\odot$ 1NO+1NC	FK 3313-M2 $\odot$ 1NO+1NC
34 <b>L</b>	FK 3408-M2 $\odot$ 2NC	FK 3410-M2 $\odot$ 2NC	FK 3412-M2 $\odot$ 2NC	FK 3413-M2 $\odot$ 2NC
Max. speed	page 231 - type 4	page 231 - type 4	page 231 - type 4	page 231 - type 2
Actuating force	5 N (25 N $\odot$ )	5 N (25 N $\odot$ )	5 N (25 N $\odot$ )	5 N (25 N $\odot$ )
Travel diagrams	page 232 - group 1	page 232 - group 1	page 232 - group 1	page 232 - group 1

All values in the drawings are in mm

Accessories See page 207

→ The 2D and 3D files are available at [www.pizzato.com](http://www.pizzato.com)



Contact type <b>R</b> = snap action <b>L</b> = slow action	Roller, Ø 11 mm, technopolymer		Steel roller, Ø 12 mm, with self-lubrication With 316L stainless steel roller on request					
Contact block								
3 <b>R</b>	<b>FK 314-M2</b>	1NO-1NC	<b>FK 315-M2</b>	1NO-1NC	<b>FK 315-M2R28</b>	1NO-1NC	<b>FK 316-M2</b>	1NO-1NC
33 <b>L</b>	<b>FK 3314-M2</b> ⊕	1NO+1NC	<b>FK 3315-M2</b> ⊕	1NO+1NC	<b>FK 3315-M2R28</b> ⊕	1NO+1NC	<b>FK 3316-M2</b> ⊕	1NO+1NC
34 <b>L</b>	<b>FK 3414-M2</b> ⊕	2NC	<b>FK 3415-M2</b> ⊕	2NC	<b>FK 3415-M2R28</b> ⊕	2NC	<b>FK 3416-M2</b> ⊕	2NC
Max. speed	page 231 - type 4		page 231 - type 2		page 231 - type 2		page 231 - type 2	
Actuating force	6 N (25 N ⊕)		5 N (25 N ⊕)		5 N (25 N ⊕)		5 N (25 N ⊕)	
Travel diagrams	page 232 - group 1		page 232 - group 1		page 232 - group 1		page 232 - group 1	

Contact type <b>R</b> = snap action <b>L</b> = slow action	Secured only by means of threaded head in vertical position		External gasket Spring rod		External gasket Spring rod		External gasket Rigid rod	
Contact block								
3 <b>R</b>	<b>FK 317-M2</b>	1NO-1NC	<b>FK 320-M2</b>	1NO-1NC	<b>FK 321-M2</b>	1NO-1NC	<b>FK 322-M2</b>	1NO-1NC
33 <b>L</b>	<b>FK 3317-M2</b> ⊕	1NO+1NC	<b>FK 3320-M2</b>	1NO+1NC	<b>FK 3321-M2</b>	1NO+1NC	<b>FK 3322-M2</b> ⊕	1NO+1NC
34 <b>L</b>	<b>FK 3417-M2</b> ⊕	2NC	<b>FK 3420-M2</b>	2NC	<b>FK 3421-M2</b>	2NC	<b>FK 3422-M2</b> ⊕	2NC
Max. speed	page 231 - type 2		1 m/s		1 m/s		1 m/s	
Actuating force	5 N (25 N ⊕)		0.05 Nm		0.05 Nm		0.05 Nm (0.25 Nm ⊕)	
Travel diagrams	page 232 - group 1		page 232 - group 4		page 232 - group 4		page 232 - group 4	

Contact type <b>R</b> = snap action <b>L</b> = slow action	External gasket Spring rod		With Ø 20 mm steel roller with self-lubrication or 316L stainless steel on request		Other rollers available. See page 112		Square rod, 3x3 mm	
Contact block								
3 <b>R</b>	<b>FK 325-M2</b>	1NO-1NC	<b>FK 330-M2</b>	1NO-1NC	<b>FK 331-M2</b>	1NO-1NC	<b>FK 333-M2</b>	1NO-1NC
33 <b>L</b>	<b>FK 3325-M2</b>	1NO+1NC	<b>FK 3330-M2</b> ⊕	1NO+1NC	<b>FK 3331-M2</b> ⊕	1NO+1NC	<b>FK 3333-M2</b>	1NO+1NC
34 <b>L</b>	<b>FK 3425-M2</b>	2NC	<b>FK 3430-M2</b> ⊕	2NC	<b>FK 3431-M2</b> ⊕	2NC	<b>FK 3433-M2</b>	2NC
Max. speed	1 m/s		page 231 - type 1		page 231 - type 1		1.5 m/s	
Actuating force	0.1 Nm		0.05 Nm (0.25 Nm ⊕)		0.05 Nm (0.25 Nm ⊕)		0.05 Nm	
Travel diagrams	page 232 - group 4		page 232 - group 5		page 232 - group 5		page 232 - group 5	

All values in the drawings are in mm

Accessories See page 207

➔ The 2D and 3D files are available at [www.pizzato.com](http://www.pizzato.com)

# FK series position switches

Contact type  
**R** = snap action  
**L** = slow action

		Round rod, Ø 3 mm, stainless steel	Other rollers available. See page 112	Other rollers available. See page 112					
Contact block									
3	<b>R</b>	FK 334-M2	1NO-1NC	FK 350-M2	1NO-1NC	FK 351-M2	1NO-1NC	FK 352-M2	1NO-1NC
33	<b>L</b>	FK 3334-M2	1NO+1NC	FK 3350-M2	1NO+1NC	FK 3351-M2	⊕	FK 3352-M2	⊕
34	<b>L</b>	FK 3434-M2	2NC	FK 3450-M2	2NC	FK 3451-M2	⊕	FK 3452-M2	⊕
Max. speed		1.5 m/s	1.5 m/s	page 231 - type 1	page 231 - type 1	page 231 - type 1	page 231 - type 1	page 231 - type 1	page 231 - type 1
Actuating force		0.05 Nm	0.05 Nm	0.05 Nm (0.25 Nm ⊕)	0.05 Nm (0.25 Nm ⊕)	0.05 Nm (0.25 Nm ⊕)	0.05 Nm (0.25 Nm ⊕)	0.05 Nm (0.25 Nm ⊕)	0.05 Nm (0.25 Nm ⊕)
Travel diagrams		page 232 - group 5	page 232 - group 5	page 232 - group 5	page 232 - group 5	page 232 - group 5	page 232 - group 5	page 232 - group 5	page 232 - group 5

Contact type  
**R** = snap action  
**L** = slow action

		Porcelain roller	Other rollers available. See page 112	Other rollers available. See page 112	Other rollers available. See page 112				
Contact block									
3	<b>R</b>	FK 353-E0M2	1NO-1NC	FK 354-M2	1NO-1NC	FK 356-M2	1NO-1NC	FK 357-M2	1NO-1NC
33	<b>L</b>	FK 3353-E0M2V9	⊕	FK 3354-M2	⊕	FK 3356-M2	⊕	FK 3357-M2	⊕
34	<b>L</b>	FK 3453-E0M2V9	⊕	FK 3454-M2	⊕	FK 3456-M2	⊕	FK 3457-M2	⊕
Max. speed		0.5 m/s	page 231 - type 1	page 231 - type 1	page 231 - type 1	page 231 - type 1	page 231 - type 1	page 231 - type 1	page 231 - type 1
Actuating force		0.02 Nm (0.25 Nm ⊕)	0.05 Nm (0.25 Nm ⊕)	0.05 Nm (0.25 Nm ⊕)	0.05 Nm (0.25 Nm ⊕)	0.05 Nm (0.25 Nm ⊕)	0.05 Nm (0.25 Nm ⊕)	0.05 Nm (0.25 Nm ⊕)	0.05 Nm (0.25 Nm ⊕)
Travel diagrams		page 232 - group 6	page 232 - group 5	page 232 - group 5	page 232 - group 5	page 232 - group 5	page 232 - group 5	page 232 - group 5	page 232 - group 5

Contact type  
**R** = snap action  
**L** = slow action

		Glass fibre rod	Rope switch for signalling		
Contact block					
3	<b>R</b>	FK 369-M2	1NO-1NC	FK 376-M2	1NO-1NC
33	<b>L</b>	FK 3369-M2	1NO+1NC	FK 3376-M2	1NO+1NC
34	<b>L</b>	FK 3469-M2	2NC	FK 3476-M2	2NO
Max. speed		1.5 m/s	0.5 m/s		
Actuating force		0.05 Nm	initial 20 N - final 40 N		
Travel diagrams		page 232 - group 5	page 232 - group 7		

(1) Positive opening only with actuator set to max. See page 112.

All values in the drawings are in mm

Accessories See page 207

→ The 2D and 3D files are available at [www.pizzato.com](http://www.pizzato.com)

## FK series position switches with reset



The majority of switches can be equipped with a reset device (option W3) which enables the simultaneous actuation of actuator and contact block. The device is a module that is mounted between the body and the head of the switch that can be rotated independently from the head. The reset device has the following advantages:

- can be integrated into the majority of standard actuator heads;
- contact blocks with snap action are no more necessary because the tripping movement is executed by the reset device itself;
- can be rotated independently from the head ensuring maximum flexibility during installation;
- can be delivered with two different actuating forces: standard and increased for vibration applications;
- mechanical endurance: 1 million operating cycles.

Contact type		With steel roller with self-lubrication or 316L stainless steel on request	With steel roller with self-lubrication or 316L stainless steel on request	With steel roller with self-lubrication or 316L stainless steel on request
<b>R</b> = snap action <b>L</b> = slow action				
Contact block				
33	<b>L</b>	FK 3301-W3M2 $\rightarrow$ 1NO+1NC	FK 3302-W3M2 $\rightarrow$ 1NO+1NC	FK 3305-W3M2 $\rightarrow$ 1NO+1NC
34	<b>L</b>	FK 3401-W3M2 $\rightarrow$ 2NC	FK 3402-W3M2 $\rightarrow$ 2NC	FK 3405-W3M2 $\rightarrow$ 2NC
Max. speed		page 231 - type 4	page 231 - type 3	page 231 - type 3
Actuating force		4.5 N (25 N $\rightarrow$ )	4 N (25 N $\rightarrow$ )	2.5 N (25 N $\rightarrow$ )
Travel diagrams		page 231 - group 1	page 231 - group 2	page 231 - group 3

Contact type		With $\varnothing$ 12 mm steel roller with self-lubrication or 316L stainless steel on request	With $\varnothing$ 20 mm steel roller with self-lubrication or 316L stainless steel on request	Other rollers available. See page 112	Other rollers available. See page 112
<b>R</b> = snap action <b>L</b> = slow action					
Contact block					
33	<b>L</b>	FK 3315-W3M2 $\rightarrow$ 1NO+1NC	FK 3330-W3M2 $\rightarrow$ 1NO+1NC	FK 3331-W3M2 $\rightarrow$ 1NO+1NC	FK 3351-W3M2 $\rightarrow$ 1NO+1NC
34	<b>L</b>	FK 3415-W3M2 $\rightarrow$ 2NC	FK 3430-W3M2 $\rightarrow$ 2NC	FK 3431-W3M2 $\rightarrow$ 2NC	FK 3451-W3M2 $\rightarrow$ 2NC
Max. speed		page 231 - type 2	page 231 - type 1	page 231 - type 1	page 231 - type 1
Actuating force		4.5 N (25 N $\rightarrow$ )	0.07 Nm (0.25 Nm $\rightarrow$ )	0.07 Nm (0.25 Nm $\rightarrow$ )	0.07 Nm (0.25 Nm $\rightarrow$ )
Travel diagrams		page 231 - group 1	page 231 - group 4	page 231 - group 4	page 231 - group 4

Contact type		Other rollers available. See page 112	Other rollers available. See page 112	Other rollers available. See page 112	Other rollers available. See page 112
<b>R</b> = snap action <b>L</b> = slow action					
Contact block					
33	<b>L</b>	FK 3352-W3M2 $\rightarrow$ 1NO+1NC	FK 3354-W3M2 $\rightarrow$ 1NO+1NC	FK 3356-W3M2 $\rightarrow$ 1NO+1NC	FK 3357-W3M2 $\rightarrow$ 1NO+1NC
34	<b>L</b>	FK 3452-W3M2 $\rightarrow$ 2NC	FK 3454-W3M2 $\rightarrow$ 2NC	FK 3456-W3M2 $\rightarrow$ 2NC	FK 3457-W3M2 $\rightarrow$ 2NC
Max. speed		page 231 - type 1	page 231 - type 1	page 231 - type 1	page 231 - type 1
Actuating force		0.07 Nm (0.25 Nm $\rightarrow$ )	0.07 Nm (0.25 Nm $\rightarrow$ )	0.07 Nm (0.25 Nm $\rightarrow$ )	0.07 Nm (0.25 Nm $\rightarrow$ )
Travel diagrams		page 231 - group 4	page 231 - group 4	page 231 - group 4	page 231 - group 4

## Position switches with swivelling lever without actuator

Contact type  
**R** = snap action  
**L** = slow action

Contact block

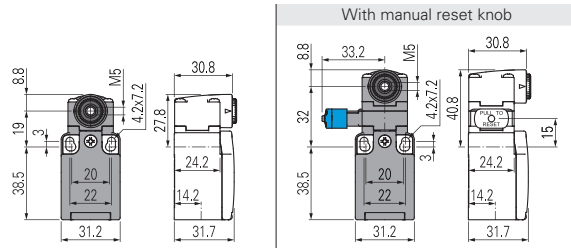

### IMPORTANT

**For safety applications:** join only switches and actuators marked with symbol  $\oplus$  next to the product code. For more information about safety applications see details on page 225.

3	<b>R</b>	FK 338-M2	1NO-1NC	/
33	<b>L</b>	FK 3338-M2 $\oplus$	1NO+1NC	FK 3338-W3M2 $\oplus$ 1NO+1NC
34	<b>L</b>	FK 3438-M2 $\oplus$	2NC	FK 3438-W3M2 $\oplus$ 2NC
Actuating force		0.06 Nm (0.25 Nm $\oplus$ )		0.07 Nm (0.25 Nm $\oplus$ )
Travel diagrams		page 232 - group 5		page 231 - group 4

## Increased actuating force



The switch can be delivered with increased actuating force (option W4). Ideal for vibration applications.

Actuators	Actuating force
01, 14, 15, 16	7 N
02, 05	6 N
07	3.5 N
30 ... 57	0.08 Nm

To order the switch with reset and increased actuating force, replace the -W3 option with -W4 in the order code.  
 Example: FK 3301-W3M1  $\rightarrow$  FK 3301-W4M1

## Separate actuators

**IMPORTANT:** These separate actuators can be used only with items of the FR, FM, FX, FZ, FK, NA, NB and NF series.

Technopolymer roller $\varnothing$ 18 mm	Technopolymer roller $\varnothing$ 18 mm	Technopolymer roller $\varnothing$ 14 mm	Technopolymer roller $\varnothing$ 14 mm	Technopolymer roller $\varnothing$ 20 mm	Technopolymer roller $\varnothing$ 20 mm
VN A00KA $\oplus$	VN A00KB $\oplus$	VN A00KC $\oplus$	VN A00KD $\oplus$	VN A00KE $\oplus$	VN A00KF $\oplus$
Technopolymer roller $\varnothing$ 20 mm	Technopolymer roller $\varnothing$ 20 mm	Adjustable safety actuator with technopolymer roller	Adjustable square rod, 3x3x125 mm	Adjustable round rod $\varnothing$ 3x125 mm	Adjustable glass fibre rod
VN A00KG $\oplus$	VN A00KH $\oplus$	VN A00KP $\oplus$	VN A00LB	VN A00LE	VN A00LH
Spring rod with plastic tip	Porcelain roller	Technopolymer roller $\varnothing$ 14 mm	Technopolymer roller $\varnothing$ 14 mm	Technopolymer roller $\varnothing$ 20 mm	Adjustable safety lever with technopolymer roller $\varnothing$ 20 mm
		With metallic parts in stainless steel			
VN A00LL	VN A00LP $\oplus$ (2)	VN A00KB-V38 $\oplus$	VN A00KE-V38 $\oplus$	VN A00KG-V38 $\oplus$	VN A00KP-V38 $\oplus$

All values in the drawings are in mm

Accessories See page 207

$\rightarrow$  The 2D and 3D files are available at [www.pizzato.com](http://www.pizzato.com)





### Special separate actuators

**IMPORTANT:** These separate actuators can be used only with items of the FR, FM, FX, FZ, FK, NA, NB and NF series.

Steel rollers, Ø 20 mm, with self-lubrication					
VN A00KB-R24 (1)	VN A00KE-R24 (1)	VN A00KF-R24 (1)	VN A00KG-R24 (1)	VN A00KH-R24 (1)	VN A00KP-R24 (1)

**Note:** To order with 316L stainless steel roller: replace R24 with R41 in the order numbers.

Technopolymer rollers, Ø 35 mm					
VN A00KB-R25 (1)	VN A00KE-R25 (1)	VN A00KF-R25 (1)	VN A00KG-R25 (1)	VN A00KH-R25 (1)	VN A00KP-R25 (1)

Rubber rollers, Ø 40 mm					
VN A00KB-R5 (1)	VN A00KE-R5 (1)	VN A00KF-R5 (1)	VN A00KG-R5 (1)	VN A00KH-R5 (1)	VN A00KP-R5 (1)

Rubber rollers, Ø 50 mm				
VN A00KE-R26 (1)	VN A00KF-R26 (1)	VN A00KG-R26 (1)	VN A00KH-R26 (1)	VN A00KP-R26 (1)

Protruding rubber rollers, Ø 50 mm
VN A00KP-R27 (1)

- (1) The actuator cannot be rotated to the inside because it will hit the switch head upon actuation.

- (2) The position switch obtained by assembling switch FK •38-M2 (e.g. FK 538-M2, FK 638-M2, ...) with actuator VN A00LP will not present the same travel diagrams and actuating forces as switch FK •53-E0M2V9 (e.g. FK 553-E0M2V9, FK 653-E0M2V9, ...).

**Note:** To check the correspondence with previous lever codes, please consult the table "Changed article codes" on page 289. Example: VF LE30 -> VN A00KA.

## Description



The result of the long-standing expertise of Pizzato Elettrica in the creation of position switches, the NA, NB, NF series achieve the highest standard of flexibility and depth of range present today on the pre-wired switches market.

Configurable, adjustable, pivotable and, not least, customisable with special cables or custom wiring - these features make these series unique in the current European panorama, ideal for easily providing our customers with customised switches.

## Switches with connectors

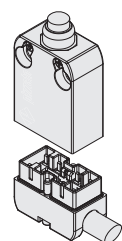

The new fundamental feature of this series of pre-wired switches is that the switch body and the wired connector are separated.

Using the connector the end-user can replace a product on field without having to disconnect the complete wiring.

Moreover in this way it is easier to combine products with different cable types and lengths.

## Head with variable orientation

All heads can be turned in 90° steps. The new head for swivelling levers has been designed with compact dimensions so that it does not protrude over the switch profile. Therefore, it is also possible to install the switches on the wall.

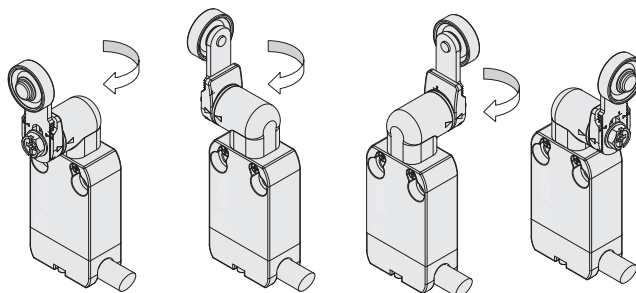

## Protection degrees IP67 and IP69K

**IP69K**  
**IP67**

These devices are designed to be used under the toughest environmental conditions, and they pass the IP67 immersion test acc. to EN 60529. They can therefore be used in all environments where the maximum degree of protection is required for the

housing. Due to their special design, these devices are suitable for use in equipment subjected to cleaning with high pressure hot water jets. These devices meet the IP69K test requirements according to ISO 20653 (water jets with 100 bar and 80°C).

## Reversible levers

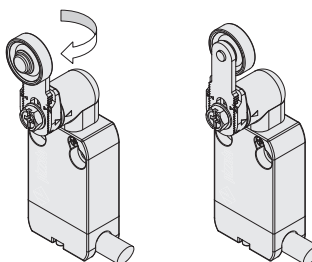

For switches with swivelling lever, the lever can be fastened on straight or reverse side maintaining the positive coupling.

In this way two different working planes of the lever are possible.

## Adjustable levers

For switches with swivelling lever, the lever can be adjusted in 10° steps over the entire 360° range.

The positive movement transmission is always guaranteed thanks to the particular geometrical coupling between the lever and the revolving shaft as prescribed for safety applications by the German standard BG-GS-ET-15.

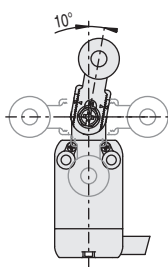

## Orientable cable outputs

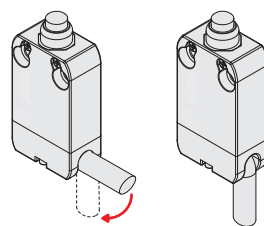

The connector with cable is provided with a cavity to allow cable bending up to 90°.

In this way a flush wall mounting is also possible as well as an easier adjustment of the cable to the supporting flange.

## 90° redirection for actuators

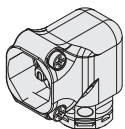

This component highly extends the application possibilities of this product range.

All the actuators that can be attached directly to the body of the switch can also be fastened on this transmission, thus making feasible applications and positioning of the switch that were previously impossible.

The redirection piece can also be used in case of heads for swivelling levers. Although technically possible, the use of multiple transmissions in series is not recommended.

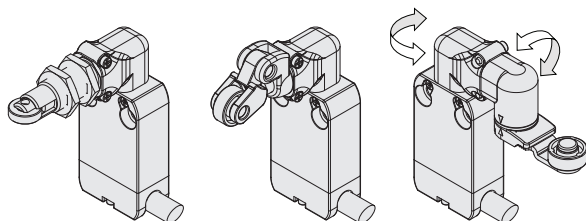

## Unidirectional heads

All switches with swivelling lever are supplied with a selector for choosing the lever operating direction.

The following operations are possible: right/left (standard factory setting), only from the right or only from the left. The operating direction can be selected by rotating the dedicated ring mounted on all heads of this kind.

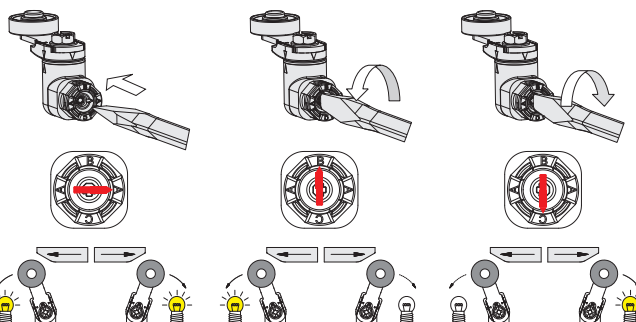

### Increased or reduced actuating force

For actuators with swivelling lever, versions with increased or reduced actuating force are available upon request, in order to have a switch perfectly tailored for the application. For further information contact our technical department.

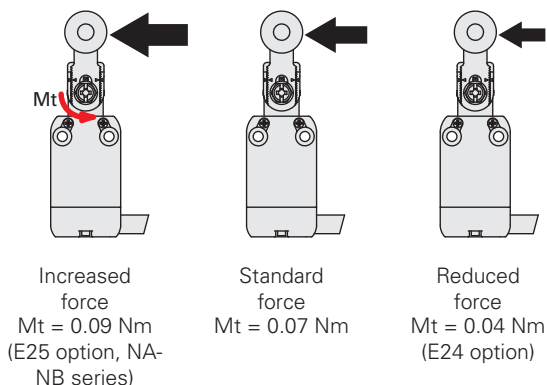

### Positive opening contact blocks with 1, 2, 3 or 4 poles

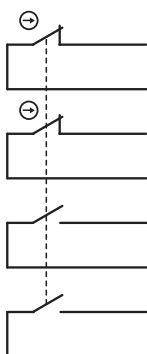

These series of contact blocks are versatile and compact.

They have the same dimensions of the previous versions, but now it is possible to have up to 4 different contacts which are galvanically separated and provided with positive opening (NC contacts).

The allowed standard combinations are: 1NO+1NC, 2NC, 1NO+2NC, 2NO+2NC. Other combinations available on request.

The contact blocks have been designed so that they keep the same pin assignment on the connector independently of the action type (slow or snap action) and the number of contacts. In this way, the same cables with connector can be used for units with slow action and snap action as well.

### Reversible housing

The shape of the fixing holes and of the switch body, as well as the possibility of rotating the head, make this switch perfectly symmetrical.

If a switch with cable output on the left (since the connector cannot be rotated) is required, it is possible to rotate the complete device by maintaining the final position of the actuator unchanged.

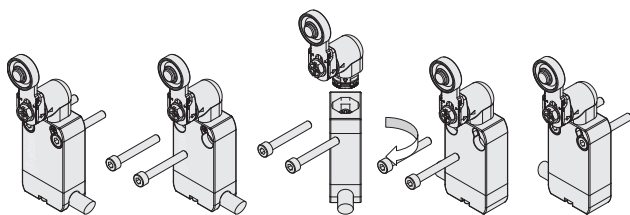

### M12 connectors

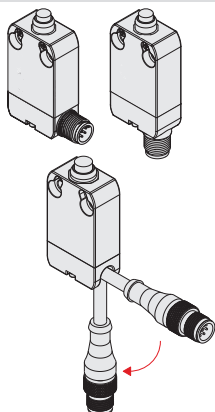

All contact configurations are available with M12 connector both with two contacts (with 5-pin M12 connector) as well as 3 or 4 contacts (with 8-pin M12 connector). Exit directions below or to the right allow application in narrow spaces; in addition the reversible housing easily allows changing the exit direction from right to left by simply turning the switch. The M12 connector is also available at the end of the cable, whose length can be tailored to the customer's requirements, and the cable can be bent at 90°, allowing installation on walls.

### Adjustable levers with anti-unscrewing washer

In some applications during the installation of the switches problems are encountered due to the variability of the fastenings and the folds of the structural work.

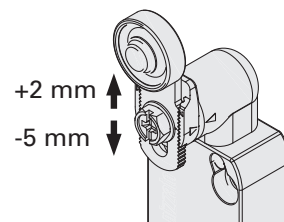

In other cases, small finishing adjustments are required due to the application. Nearly all swivelling levers for switches of the NA, NB and NF series can be adjusted in 1 mm steps along the switch length.

This feature, combined with the additional possibility of the radial adjustment of the actuator, provides the installer with a never before achieved flexibility in the final adjustment of the product.

All this while maintaining the positive geometric locking between lever and swivel shaft as prescribed for safety applications.

### Switch components available separately

This product series has been provided with a modular design so that single parts can also be ordered separately. This is an asset both for distributors and for final customers of electrical material in the procurement of spare parts as well as for custom combinations.

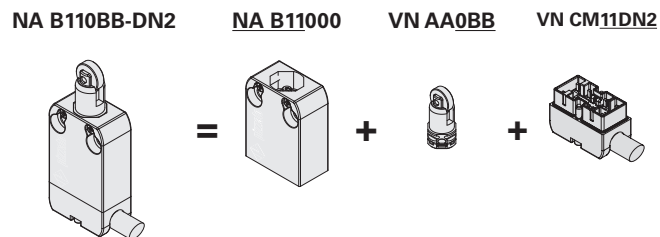

### Extended temperature range

**-40°C**

These devices are also available in a special version suitable for an ambient operating temperature range from -40°C up to +80°C.

They can therefore be used for applications in cold stores, sterilisers, and other equipment operated in very low-temperature environments. The special materials used to produce these versions retain their characteristics even under these conditions, thereby expanding the installation possibilities.

### AMP connectors

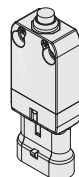

Furthermore, AMP connectors for 2-contact versions are available too. These connectors, specially developed for the automotive industry, are immune to vibration due to the quick coupling.

### High reliability contacts with "V" design

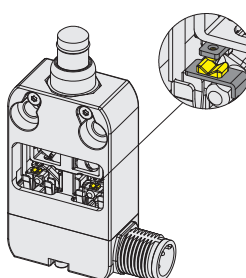

Articles with contact block C11, C02, C12, C22 are characterised by electrical contacts with a "V" design. This configuration reduces the possibility of error during operation and guarantees even more reliable contact switching, thanks to the contact points doubled compared to the flat-shaped contacts and the self-cleaning action of the contact. In the version with snap action contact, these articles are particularly suitable for use in the railway sector.

Selection diagram for item combinations of the NA-NB series

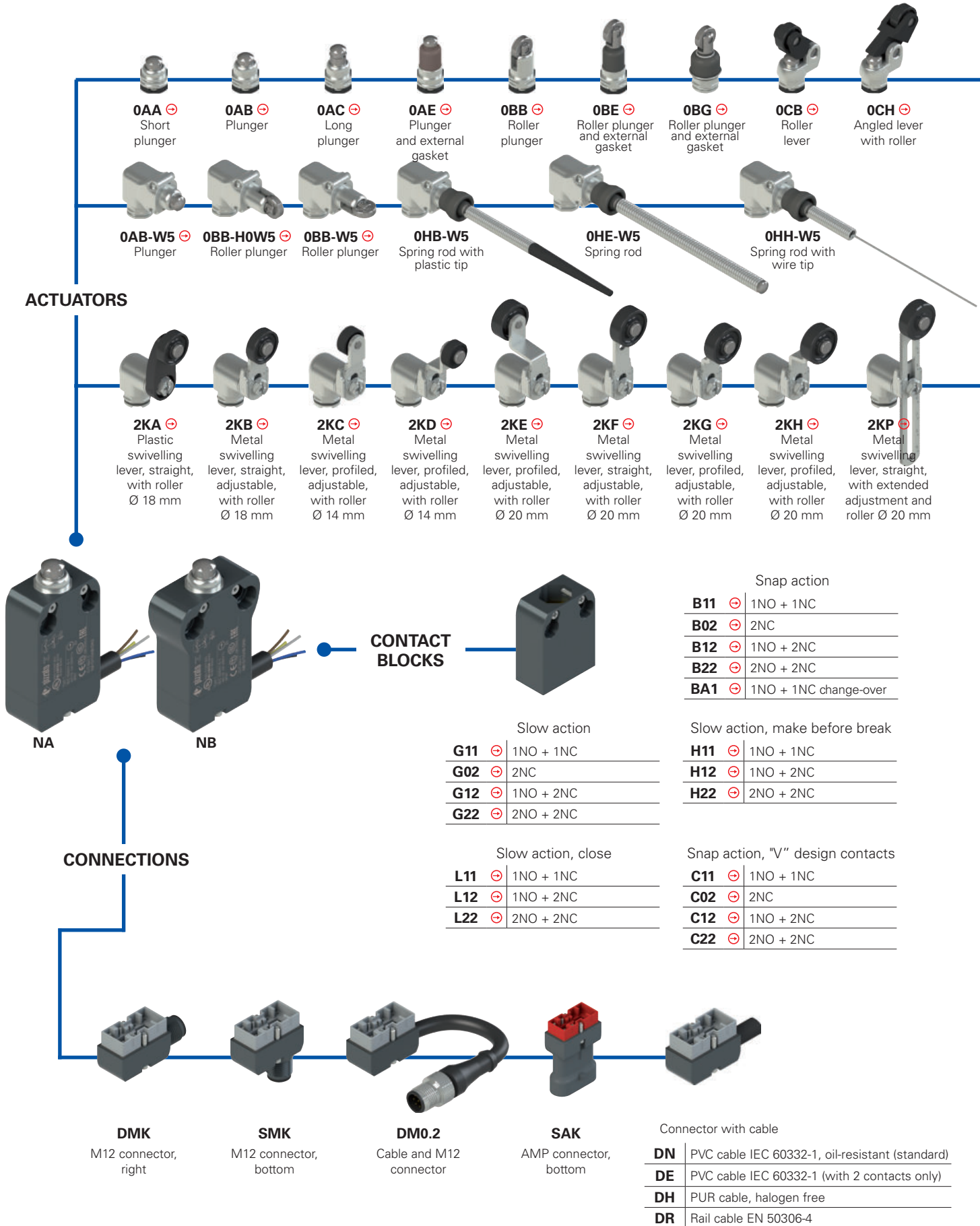

● Product options  
 → Sold separately as accessory

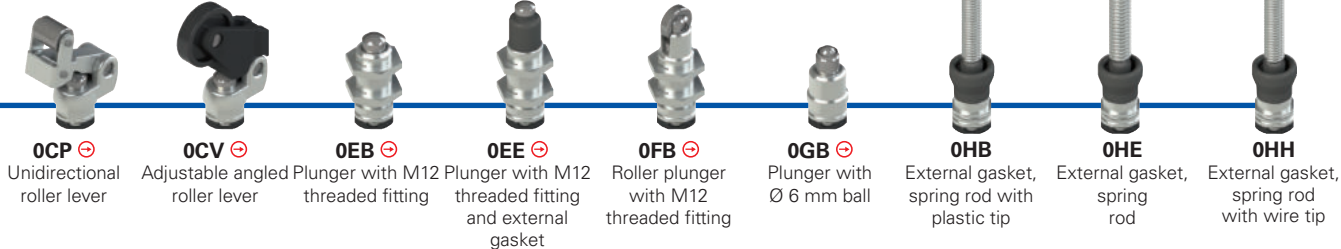

- OCP** ⊕ Unidirectional roller lever
- OCV** ⊕ Adjustable angled roller lever
- OEB** ⊕ Plunger with M12 threaded fitting
- OEE** ⊕ Plunger with M12 threaded fitting and external gasket
- OFB** ⊕ Roller plunger with M12 threaded fitting
- OGB** ⊕ Plunger with Ø 6 mm ball
- OHB** External gasket, spring rod with plastic tip
- OHE** External gasket, spring rod
- OHH** External gasket, spring rod with wire tip

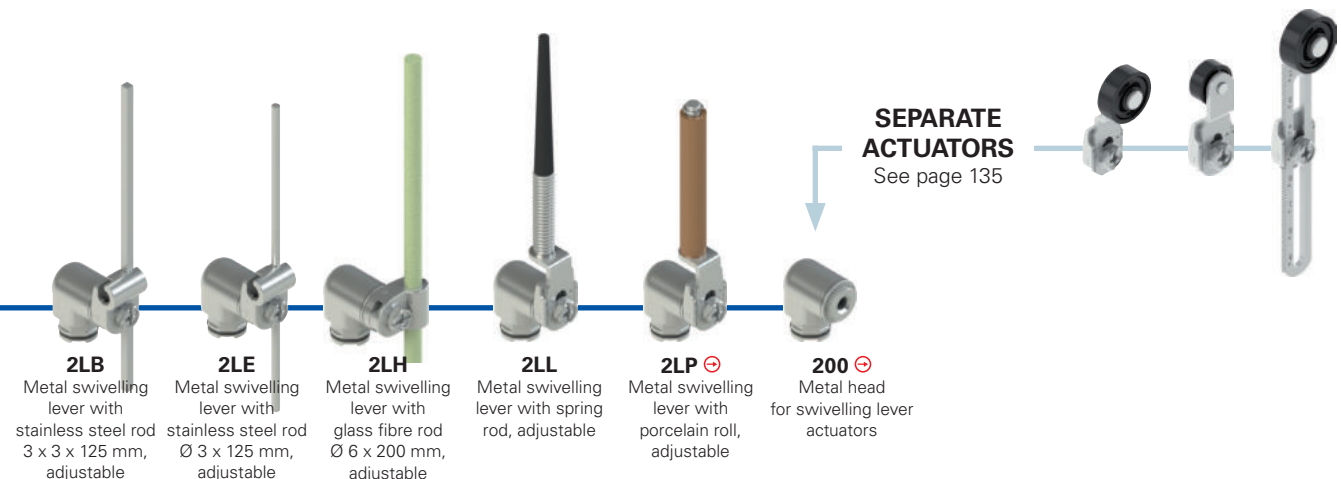

- 2LB** Metal swivelling lever with stainless steel rod 3 x 3 x 125 mm, adjustable
- 2LE** Metal swivelling lever with stainless steel rod Ø 3 x 125 mm, adjustable
- 2LH** Metal swivelling lever with glass fibre rod Ø 6 x 200 mm, adjustable
- 2LL** Metal swivelling lever with spring rod, adjustable
- 2LP** ⊕ Metal swivelling lever with porcelain roll, adjustable
- 200** ⊕ Metal head for swivelling lever actuators

**SEPARATE ACTUATORS**  
See page 135



**Code structure**

**Attention!** The feasibility of a code number does not mean the effective availability of a product. Please contact our sales office.

Housing		article		options	
<b>NA</b>	metal, hole spacing 20 mm (standard)	<b>NA B110AB-DN2</b>		<b>GR7T6W5</b>	
<b>NB</b>	metal, hole spacing 25 mm				
				<b>Redirection</b>	
				without redirection	
				<b>W5</b> 90° redirection	
				<b>Ambient temperature</b>	
				-25°C ... +80°C	
				<b>T6</b> -40°C ... +80°C	
				<b>Rollers</b>	
				standard roller	
				<b>R30</b> Steel, with self-lubrication, Ø 10.6 mm	
				<b>R44</b> 316L stainless steel, Ø 12 mm	
				<b>R29</b> Steel, with self-lubrication, Ø 13 mm	
				<b>R18</b> technopolymer, Ø 14 mm	
				<b>R23</b> Steel, with self-lubrication, Ø 14 mm	
				<b>R43</b> 316L stainless steel, Ø 14 mm	
				<b>R36</b> Steel, with self-lubrication, Ø 16 mm	
				<b>R7</b> technopolymer, Ø 18 mm	
				<b>R22</b> technopolymer, Ø 20 mm	
				<b>R24</b> Steel, with self-lubrication, Ø 20 mm	
				<b>R41</b> 316L stainless steel, Ø 20 mm	
				<b>R19</b> technopolymer, Ø 22 mm	
				<b>R25</b> technopolymer, Ø 35 mm	
				<b>Contact type</b>	
				silver contacts (standard)	
				<b>G</b> silver contacts with 1 µm gold coating <sup>(1)</sup>	
				<sup>(1)</sup> Not available for contact block C••	
				<b>Connection type</b>	
				<b>0.2</b> cable, length: 0.2 m with M12 connector (available for DM0.2 versions only)	
				<b>2</b> cable, length: 2 m (standard)	
				<b>5</b> cable, length 5 m (other cable lengths available on request)	
				<b>K</b> integrated connector	
				<b>Cable or connector type</b>	
				<b>N</b> PVC cable IEC 60332-1, oil-resistant (standard)	
				<b>E</b> PVC cable IEC 60332-1 (with 2 contacts only)	
				<b>H</b> PUR cable, halogen free	
				<b>R</b> Rail cable EN 50306-4	
				<b>M</b> M12 connector	
				<b>A</b> AMP Superseal 1.5 connector	
<b>Contact block</b>					
<b>B11</b>		1NO+1NC, snap action (standard)			
<b>B02</b>		2NC, snap action (standard)			
<b>B12</b>		1NO+2NC, snap action (standard)			
<b>B22</b>		2NO+2NC, snap action (standard)			
<b>BA1</b>		1NO+1NC, snap action, change-over (available with M connector only)			
<b>C11</b>		1NO+1NC, snap action, "V" design contacts			
<b>C02</b>		2NC, snap action, "V" design contacts			
<b>C12</b>		1NO+2NC, snap action, "V" design contacts			
<b>C22</b>		2NO+2NC, snap action, "V" design contacts			
<b>G11</b>		1NO+1NC, slow action (standard)			
<b>G02</b>		2NC, slow action (standard)			
<b>G12</b>		1NO+2NC, slow action (standard)			
<b>G22</b>		2NO+2NC, slow action			
<b>H11</b>		1NO+1NC, slow action, make before break			
<b>H12</b>		1NO+2NC, slow action, make before break			
<b>H22</b>		2NO+2NC, slow action, make before break			
<b>L11</b>		1NO+1NC, slow action, close			
<b>L12</b>		1NO+2NC, slow action, close			
<b>L22</b>		2NO+2NC, slow action, close			
		Other contact blocks on request.			
<b>Actuator heads</b>		<b>Actuators</b>		<b>Output direction</b>	
<b>0</b>		without head		<b>D</b> cable or connector, right	
<b>2</b>		head for swivelling lever actuators		<b>S</b> connector, bottom	
		<b>00</b> without actuator			
		<b>AA</b> short plunger			
		<b>AB</b> plunger			
		...			



### Main features

- Metal housing, right or bottom cable output
- Protection degrees IP67 and IP69K
- 4 types of integrated cable available
- Versions with M12 connector suitable for safety applications  $\ominus$
- Versions with AMP connector
- 19 contact blocks available
- 36 actuators available

### Quality marks:



IMQ approval:	CA02.04562
UL approval:	E131787
CCC approval:	2021000305000109
EAC approval:	RU C-IT.YT03.B.00035/19

### Technical data

#### Housing

Metal housing, baked with UV resistant powder coating.  
Versions with integrated cable, standard length 2 m, other lengths 0.5 ... 10 m on request.

Versions with integrated M12 connector.

Versions with 0.2 m cable length and M12 connector, other lengths 0.1 ... 3 m available on request.

Protection degree:	IP67 acc. to EN 60529 IP69K acc. to ISO 20653 (Protect the cables from direct high-pressure and high-temperature jets)
--------------------	--

Corrosion resistance in saline mist:	≥ 300 hours in NSS acc. to ISO 9227
--------------------------------------	-------------------------------------

#### General data

Ambient temperature for switches without cable: -25°C ... + 80°C (standard)  
-40°C ... + 80°C (T6 option)

Ambient temperature for switches with cable: See table on page 118  
Max. actuation frequency: 3600 operating cycles/hour

Mechanical endurance:

B••, G••, H••, L•• contact blocks:	20 million operating cycles
C•• contact block:	5 million operating cycles

Mounting position:

any

Safety parameter  $B_{10D}$ :

B••, G••, H••, L•• contact blocks:	40,000,000 for NC contacts
C•• contact block:	10,000,000 for NC contacts

Mechanical interlock, not coded:

type 1 acc. to EN ISO 14119

Vibration resistance

5 ... 150 Hz (7.9 m/s<sup>2</sup>)

(0BB, 2KB, 2KC, 2KD actuators):

acc. to EN 61373 cl. 9

Tightening torques for installation:

see page 235

#### Electrical data

Rated impulse withstand voltage ( $U_{imp}$ ): 4 kV

Conditional short circuit current: 1000 A acc. to EN 60947-5-1

Pollution degree: 3

#### In compliance with standards:

IEC 60947-5-1, EN 60947-5-1, IEC 60204-1, EN 60204-1, EN ISO 14119, EN ISO 12100, IEC 60529, EN 60529, EN IEC 63000, ISO 20653, UL 508, CSA C22.2 No. 14.

#### Compliance with the requirements of:

Low Voltage Directive 2014/35/EU, EMC Directive 2014/30/EU, RoHS Directive 2011/65/EU.

#### Positive contact opening in conformity with standards:

IEC 60947-5-1, EN 60947-5-1.

### ⚠ Installation for safety applications:

Use only switches marked with the  $\ominus$  symbol beside the product code. Always connect the safety circuit to the **NC contacts** (normally closed contacts: see "Internal cable wiring" on page 118) as required by **EN ISO 14119, paragraph 5.4** for specific interlock applications and **EN ISO 13849-2 tables D3 (well-ried components) and D.8 (fault exclusions)** for safety applications in general. Actuate the switch **at least up to the positive opening travel** shown in the travel diagrams on page 236. Actuate the switch **at least with the positive opening force**, reported in brackets below each article, next to the actuating force value.

⚠ If not expressly indicated in this chapter, for correct installation and utilization of all articles see the instructions given on pages 227 to 242.

⚠ Important: Switch off the circuit voltage before disconnecting the connector from the switch. The connector is not suitable for separation of electrical loads. According to EN 60204-1, versions with 8-pole M12 (2NO+2NC) and AMP connector can be used only in SELV circuits.

### Features approved by IMQ

Rated insulation voltage ( $U_i$ ):	250 Vac
Conventional free air thermal current ( $I_{th}$ ):	10 A (1-2 contacts) / 6 A (2-3 contacts) / 4 A (4 contacts or 5-pole M12 connector)
Protection against short circuits (fuse):	10 A (1-2 contacts) / 6 A (2-3 contacts) / 4 A (4 contacts or 5-pole M12 connector) type gG
Rated impulse withstand voltage ( $U_{imp}$ ):	4 kV
Protection degree of the housing:	IP67 / IP69K
MA terminals (crimped terminals)	
Pollution degree:	3
Utilization category:	AC15 / DC13 (with connector)
Operating voltage ( $U_o$ ):	250 Vac (50 Hz) / 24 Vdc (with connector)
Operating current ( $I_o$ ):	3 A / 2 A (with connector)

Forms of the contact element: X, Y, X+Y, X+X, Y+Y, Y+Y+X, X+X+Y, X+X+Y+Y, Zb  
Positive opening of contacts on contact blocks B01, B11, B02, B12, B21, B22, G01, G11, G02, G12, G21, G22, L01, L11, L02, L12, L21, L22, H01, H11, H02, H12, H21, H22

In compliance with standards: EN 60947-1, EN 60947-5-1, fundamental requirements of the Low Voltage Directive 2014/35/EU.

Please contact our technical department for the list of approved products.

### Features approved by UL

Electrical Ratings:	R300 pilot duty (28 VA, 125 250 Vdc) B300 pilot duty (360 VA, 120 240 Vac) (1 cont.) B300 pilot duty (360 VA, 120 240 Vac) (2 - 3 cont. without connector) C300 pilot duty (180 VA, 120 240 Vac) (4 cont.)
Environmental Ratings:	Types 1, 4X, 6, 12, 13 Types 1, 4X "indoor use only" (1 - 2 cont. with "E" type cable)
Screws torque of the detachable connector housing nominal are	0.3 ÷ 0.6 Nm.

Please contact our technical department for the list of approved products.



## Ambient temperatures for switches with cable and electrical data

Connection type	Output with cable								Output with M12 connector		Output with AMP connector
	2 contacts				3 contacts		4 contacts		2 contacts	3 or 4 contacts	2 contacts
	E	N	H	R	N	H	N	R	M12 connector, 5-pole	M12 connector, 8-pole	AMP Super-seal 1.5 connector
<b>Conductors</b>	5x0.75 mm <sup>2</sup>	5x0.75 mm <sup>2</sup>	5x0.75 mm <sup>2</sup>	5x0.5mm <sup>2</sup>	7x0.5 mm <sup>2</sup>	7x0.5 mm <sup>2</sup>	9x0.34 mm <sup>2</sup>	9x0.5 mm <sup>2</sup>	5x0.25 mm <sup>2</sup>	8x0.25 mm <sup>2</sup>	
<b>Application field</b>	General	General	General, mobile installation	Rail	General	General, mobile installation	General	Rail	General	General	General
<b>In compliance with standards</b>	H05V-F	05VV5-F	05EQ-H	EN50306-4 IE-300V 5G0.5 mm <sup>2</sup> MM-30 EN 50306-4 EN 45545	03VV-F	03E7Q-H	03VV-F	EN50306-4 IE-300V 9G0.5 mm <sup>2</sup> MM-30 EN 50306-4 EN 45545	03VV-H	03VW-H	/
<b>Sheath</b>	PVC	PVC OIL RESISTANT	PUR HALOGEN FREE	/	PVC OIL RESISTANT	PUR HALOGEN FREE	PVC OIL RESISTANT	/	PVC OIL RESISTANT	PVC OIL RESISTANT	/
<b>Self-extinguishing</b>	IEC 60332-1-2	IEC 60332-1-2 UL 758:FT1 CEI 20-22 II	IEC 60332-1-2 UL 758:FT1	IEC 60332-1 EN 50305 EN 50306-1	IEC 60332-1-2 UL 758:FT1 CEI 20-22 II	IEC 60332-1-2 UL 758:FT1	IEC 60332-1-2 UL 758:FT1 CEI 20-22 II	IEC 60332-1 EN 50305 EN 50306-1	IEC 60332-1-2 CEI 20-22 II UL 758:FT1	IEC 60332-1-2 CEI 20-22 II UL 758:FT1	/
<b>Oil resistant</b>	/	UL 758 CSA 22.2 N°210	UL 758 CSA 22.2 N°210	/	UL 758 CSA 22.2 N°210	UL 758 CSA 22.2 N°210	UL 758 CSA 22.2 N°210	/	UL 758 CSA 22.2 N°210	UL 758 CSA 22.2 N°210	/
<b>Max. speed</b>	/	/	300 m/min	/	/	300 m/min	/	/	50 m/min	50 m/min	/
<b>Max. acceleration</b>	/	/	30 m/s <sup>2</sup>	/	/	30 m/s <sup>2</sup>	/	/	5 m/s <sup>2</sup>	5 m/s <sup>2</sup>	/
<b>Minimum bending radius</b>	80 mm	80 mm	80 mm	60 mm	108 mm	80 mm	108 mm	65 mm	75 mm	90 mm	/
<b>Outer diameter</b>	8 mm	8 mm	8 mm	6 mm	7 mm	7 mm	7 mm	6.5 mm	6 mm	6 mm	/
<b>End stripped</b>	80 mm	80 mm	80 mm	80 mm	80 mm	80 mm	80 mm	80 mm	/	/	/
<b>Copper conductors IEC 60228</b>	Class 5	Class 5	Class 6	Class 5	Class 5	Class 6	Class 5	Class 5	Class 6	Class 6	/
<b>Engraving</b>	Standard	6268	6280	Standard	6274	6282	6278	Standard	6267	6275	/

Ambient temperature with cable extended (T <sub>0</sub> )	Cable, fixed installation	-15°C +60°C	-25°C +80°C	-25°C +80°C	-25°C +80°C	-25°C +80°C	-25°C +80°C	-25°C +80°C	-25°C +80°C	-25°C +80°C	-25°C +80°C	/
	Cable, flexible installation	+5°C +60°C	-5°C +80°C	-25°C +80°C	-25°C +80°C	-5°C +80°C	-25°C +80°C	-5°C +80°C	-25°C +80°C	-15°C +80°C	-15°C +80°C	/
	Cable, mobile installation	/	/	-25°C +80°C	/	/	-25°C +80°C	/	/	-15°C +80°C	-15°C +80°C	/
	Cable, fixed installation	/	/	-40°C +80°C	-40°C +80°C	/	-40°C +80°C	/	-40°C +80°C	/	/	/
	Cable, flexible installation	/	/	-40°C +80°C	-40°C +80°C	/	-40°C +80°C	/	-40°C +80°C	/	/	/
	Cable, mobile installation	/	/	-40°C +80°C	/	/	-40°C +80°C	/	/	/	/	/

  

Electrical data	Thermal current I <sub>th</sub>	10 A	10 A	10 A	6 A	6 A	6 A	3 A	4 A	4 A	2 A	10 A	
	Rated insulation voltage U <sub>i</sub>	250 Vac	250 Vac	250 Vac	250 Vac	250 Vac	250 Vac	250 Vac	250 Vac	250 Vac	30 Vac 300 Vdc	30 Vac	
	Protection against short circuits (fuse)	10 A 500 V type gG	10 A 500 V type gG	10 A 500 V type gG	6 A 500 V type gG	6 A 500 V type gG	6 A 500 V type gG	3 A 500 V type gG	4 A 500 V type gG	4 A 500 V type gG	4 A 500 V type gG	2 A 500V type gG	10 A 500 V type gG
	Utilization category DC13	24 V	2 A	2 A	2 A	2 A	2 A	2 A	2 A	2 A	2 A	2 A	2 A
		125 V	0.4 A	0.4 A	0.4 A	0.4 A	0.4 A	0.4 A	0.4 A	0.4 A	0.4 A	/	/
		250 V	0.3 A	0.3 A	0.3 A	0.3 A	0.3 A	0.3 A	0.3 A	0.3 A	0.3 A	/	/
Utilization category AC15	24 V	4 A	4 A	4 A	4 A	4 A	4 A	3 A	4 A	4 A	2 A	4 A	
	120 V	4 A	4 A	4 A	4 A	4 A	4 A	3 A	4 A	4 A	/	/	
	250 V	4 A	4 A	4 A	4 A	4 A	4 A	3 A	4 A	4 A	/	/	

  

Approvals	CE cULus IMQ EAC CCC	CE cULus IMQ EAC CCC	CE cULus IMQ EAC CCC	CE IMQ EAC CCC	CE cULus IMQ EAC CCC	CE cULus IMQ EAC CCC	CE cULus IMQ EAC CCC	CE cULus IMQ EAC CCC	CE IMQ EAC CCC	CE cULus IMQ EAC CCC	CE cULus EAC	CE cULus EAC
-----------	----------------------------	----------------------------	----------------------------	----------------------	----------------------------	----------------------------	----------------------------	----------------------------	----------------------	----------------------------	-----------------	-----------------

### Internal cable wiring

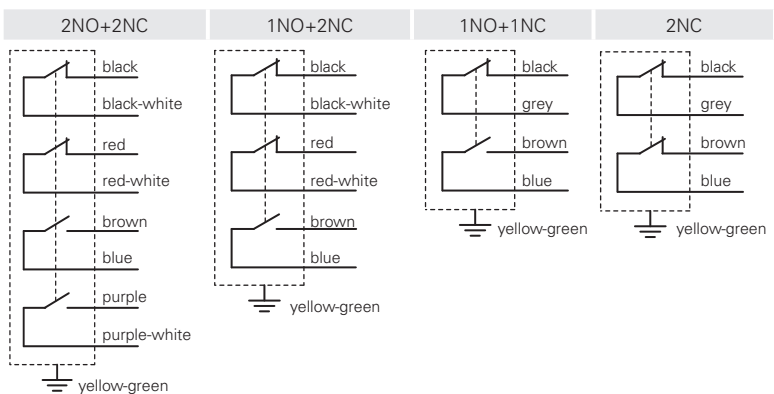

### Connector pin assignment

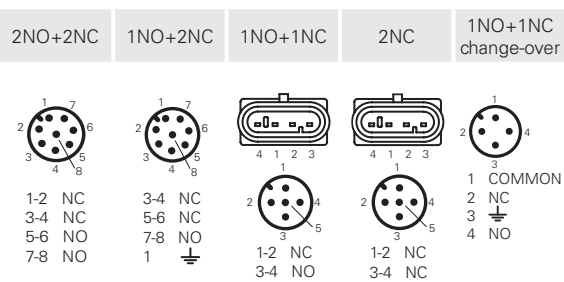

Female connectors see page 210

# NA-NB series modular metal pre-wired switches

External gasket																																			
<p>Contact type</p> <p><b>R</b> = snap action</p> <p><b>L</b> = slow action</p>																																			
<p>Contact block</p> <table border="1"> <tr> <td>B11</td> <td><b>R</b></td> <td>NA B110AA-DN2</td> <td>1NO+1NC</td> </tr> <tr> <td>B02</td> <td><b>R</b></td> <td>NA B020AA-DN2</td> <td>2NC</td> </tr> <tr> <td>B12</td> <td><b>R</b></td> <td>NA B120AA-DN2</td> <td>1NO+2NC</td> </tr> <tr> <td>B22</td> <td><b>R</b></td> <td>NA B220AA-DN2</td> <td>2NO+2NC</td> </tr> <tr> <td>G11</td> <td><b>L</b></td> <td>NA G110AA-DN2</td> <td>1NO+1NC</td> </tr> <tr> <td>G02</td> <td><b>L</b></td> <td>NA G020AA-DN2</td> <td>2NC</td> </tr> <tr> <td>G12</td> <td><b>L</b></td> <td>NA G120AA-DN2</td> <td>1NO+2NC</td> </tr> <tr> <td>G22</td> <td><b>L</b></td> <td>NA G220AA-DN2</td> <td>2NO+2NC</td> </tr> </table>	B11	<b>R</b>	NA B110AA-DN2	1NO+1NC	B02	<b>R</b>	NA B020AA-DN2	2NC	B12	<b>R</b>	NA B120AA-DN2	1NO+2NC	B22	<b>R</b>	NA B220AA-DN2	2NO+2NC	G11	<b>L</b>	NA G110AA-DN2	1NO+1NC	G02	<b>L</b>	NA G020AA-DN2	2NC	G12	<b>L</b>	NA G120AA-DN2	1NO+2NC	G22	<b>L</b>	NA G220AA-DN2	2NO+2NC			
B11	<b>R</b>	NA B110AA-DN2	1NO+1NC																																
B02	<b>R</b>	NA B020AA-DN2	2NC																																
B12	<b>R</b>	NA B120AA-DN2	1NO+2NC																																
B22	<b>R</b>	NA B220AA-DN2	2NO+2NC																																
G11	<b>L</b>	NA G110AA-DN2	1NO+1NC																																
G02	<b>L</b>	NA G020AA-DN2	2NC																																
G12	<b>L</b>	NA G120AA-DN2	1NO+2NC																																
G22	<b>L</b>	NA G220AA-DN2	2NO+2NC																																
Max. speed	page 235 - type 4																																		
Actuating force	7 N (25 N)																																		
Travel diagrams	page 236 - group 1																																		

External gasket	External gasket	External gasket	With steel roller with self-lubrication or 316L stainless steel on request																																
<p>Contact type</p> <p><b>R</b> = snap action</p> <p><b>L</b> = slow action</p>																																			
<p>Contact block</p> <table border="1"> <tr> <td>B11</td> <td><b>R</b></td> <td>NA B110BB-DN2</td> <td>1NO+1NC</td> </tr> <tr> <td>B02</td> <td><b>R</b></td> <td>NA B020BB-DN2</td> <td>2NC</td> </tr> <tr> <td>B12</td> <td><b>R</b></td> <td>NA B120BB-DN2</td> <td>1NO+2NC</td> </tr> <tr> <td>B22</td> <td><b>R</b></td> <td>NA B220BB-DN2</td> <td>2NO+2NC</td> </tr> <tr> <td>G11</td> <td><b>L</b></td> <td>NA G110BB-DN2</td> <td>1NO+1NC</td> </tr> <tr> <td>G02</td> <td><b>L</b></td> <td>NA G020BB-DN2</td> <td>2NC</td> </tr> <tr> <td>G12</td> <td><b>L</b></td> <td>NA G120BB-DN2</td> <td>1NO+2NC</td> </tr> <tr> <td>G22</td> <td><b>L</b></td> <td>NA G220BB-DN2</td> <td>2NO+2NC</td> </tr> </table>	B11	<b>R</b>	NA B110BB-DN2	1NO+1NC	B02	<b>R</b>	NA B020BB-DN2	2NC	B12	<b>R</b>	NA B120BB-DN2	1NO+2NC	B22	<b>R</b>	NA B220BB-DN2	2NO+2NC	G11	<b>L</b>	NA G110BB-DN2	1NO+1NC	G02	<b>L</b>	NA G020BB-DN2	2NC	G12	<b>L</b>	NA G120BB-DN2	1NO+2NC	G22	<b>L</b>	NA G220BB-DN2	2NO+2NC			
B11	<b>R</b>	NA B110BB-DN2	1NO+1NC																																
B02	<b>R</b>	NA B020BB-DN2	2NC																																
B12	<b>R</b>	NA B120BB-DN2	1NO+2NC																																
B22	<b>R</b>	NA B220BB-DN2	2NO+2NC																																
G11	<b>L</b>	NA G110BB-DN2	1NO+1NC																																
G02	<b>L</b>	NA G020BB-DN2	2NC																																
G12	<b>L</b>	NA G120BB-DN2	1NO+2NC																																
G22	<b>L</b>	NA G220BB-DN2	2NO+2NC																																
Max. speed	page 235 - type 2	page 235 - type 5	page 235 - type 3																																
Actuating force	7 N (25 N)	7 N (25 N)	5 N (25 N)																																
Travel diagrams	page 236 - group 1	page 236 - group 1	page 236 - group 2																																

NB series housing	M12 connector, right	M12 connector, bottom	AMP Superseal 1.5 connector
<p>To order a product of the NB series, replace NA with NB in the codes shown above. Example: NA B110AA-DN2 → NB B110AA-DN2</p>	<p>To order a product with M12 right connector, replace DN2 with DMK in the codes shown above. Example: NA B110AA-DN2 → NA B110AA-DMK</p>	<p>To order a product with M12 bottom connector, replace DN2 with SMK in the codes shown above. Example: NA B110AA-DN2 → NA B110AA-SMK</p>	<p>To order a product with AMP connector, replace DN2 with SAK in the codes shown above. Example: NA B110AA-DN2 → NA B110AA-SAK</p>

All values in the drawings are in mm

Accessories See page 207

The 2D and 3D files are available at [www.pizzato.com](http://www.pizzato.com)





Contact type <b>R</b> = snap action <b>L</b> = slow action	With steel roller with self-lubrication or 316L stainless steel on request	Unidirectional operation	Secured only by means of threaded head	
			It does not switch → It switches ← 	
Contact block				
B11 <b>R</b>	NA B110CH-DN2 ⊕ 1NO+1NC	NA B110CP-DN2 ⊕ 1NO+1NC	NA B110CV-DN2 ⊕ 1NO+1NC	NA B110EB-DN2 ⊕ 1NO+1NC
B02 <b>R</b>	NA B020CH-DN2 ⊕ 2NC	NA B020CP-DN2 ⊕ 2NC	NA B020CV-DN2 ⊕ 2NC	NA B020EB-DN2 ⊕ 2NC
B12 <b>R</b>	NA B120CH-DN2 ⊕ 1NO+2NC	NA B120CP-DN2 ⊕ 1NO+2NC	NA B120CV-DN2 ⊕ 1NO+2NC	NA B120EB-DN2 ⊕ 1NO+2NC
B22 <b>R</b>	NA B220CH-DN2 ⊕ 2NO+2NC	NA B220CP-DN2 ⊕ 2NO+2NC	NA B220CV-DN2 ⊕ 2NO+2NC	NA B220EB-DN2 ⊕ 2NO+2NC
G11 <b>L</b>	NA G110CH-DN2 ⊕ 1NO+1NC	NA G110CP-DN2 ⊕ 1NO+1NC	NA G110CV-DN2 ⊕ 1NO+1NC	NA G110EB-DN2 ⊕ 1NO+1NC
G02 <b>L</b>	NA G020CH-DN2 ⊕ 2NC	NA G020CP-DN2 ⊕ 2NC	NA G020CV-DN2 ⊕ 2NC	NA G020EB-DN2 ⊕ 2NC
G12 <b>L</b>	NA G120CH-DN2 ⊕ 1NO+2NC	NA G120CP-DN2 ⊕ 1NO+2NC	NA G120CV-DN2 ⊕ 1NO+2NC	NA G120EB-DN2 ⊕ 1NO+2NC
G22 <b>L</b>	NA G220CH-DN2 ⊕ 2NO+2NC	NA G220CP-DN2 ⊕ 2NO+2NC	NA G220CV-DN2 ⊕ 2NO+2NC	NA G220EB-DN2 ⊕ 2NO+2NC
Max. speed	page 235 - type 3	page 235 - type 3	page 235 - type 3	page 235 - type 4
Actuating force	5 N (25 N ⊕)	3 N (25 N ⊕)	3 N (25 N ⊕)	7 N (25 N ⊕)
Travel diagrams	page 236 - group 2	page 236 - group 6	page 236 - group 3	page 236 - group 1

Contact type <b>R</b> = snap action <b>L</b> = slow action	External gasket	Secured only by means of threaded head	Plunger with Ø 6 mm ball	External gasket
		Secured only by means of threaded head 	With Ø12 mm roller in 316L stainless steel on request 	
Contact block				
B11 <b>R</b>	NA B110EE-DN2 ⊕ 1NO+1NC	NA B110FB-DN2 ⊕ 1NO+1NC	NA B110GB-DN2 ⊕ 1NO+1NC	NA B110HB-DN2 1NO+1NC
B02 <b>R</b>	NA B020EE-DN2 ⊕ 2NC	NA B020FB-DN2 ⊕ 2NC	NA B020GB-DN2 ⊕ 2NC	NA B020HB-DN2 2NC
B12 <b>R</b>	NA B120EE-DN2 ⊕ 1NO+2NC	NA B120FB-DN2 ⊕ 1NO+2NC	NA B120GB-DN2 ⊕ 1NO+2NC	NA B120HB-DN2 1NO+2NC
B22 <b>R</b>	NA B220EE-DN2 ⊕ 2NO+2NC	NA B220FB-DN2 ⊕ 2NO+2NC	NA B220GB-DN2 ⊕ 2NO+2NC	NA B220HB-DN2 2NO+2NC
G11 <b>L</b>	NA G110EE-DN2 ⊕ 1NO+1NC	NA G110FB-DN2 ⊕ 1NO+1NC	NA G110GB-DN2 ⊕ 1NO+1NC	/
G02 <b>L</b>	NA G020EE-DN2 ⊕ 2NC	NA G020FB-DN2 ⊕ 2NC	NA G020GB-DN2 ⊕ 2NC	NA G020HB-DN2 2NC
G12 <b>L</b>	NA G120EE-DN2 ⊕ 1NO+2NC	NA G120FB-DN2 ⊕ 1NO+2NC	NA G120GB-DN2 ⊕ 1NO+2NC	/
G22 <b>L</b>	NA G220EE-DN2 ⊕ 2NO+2NC	NA G220FB-DN2 ⊕ 2NO+2NC	NA G220GB-DN2 ⊕ 2NO+2NC	/
Max. speed	page 235 - type 4	page 235 - type 2	page 235 - type 2	1 m/s
Actuating force	7 N (25 N ⊕)	7 N (25 N ⊕)	7 N (25 N ⊕)	0.03 Nm
Travel diagrams	page 236 - group 1	page 236 - group 1	page 236 - group 1	page 236 - group 4

Cable and M12 connector

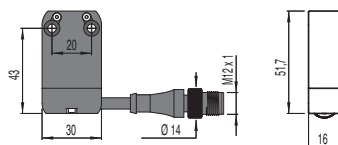

To order a product with cable and M12 connector replace DN2 with DM0.2 in the codes shown above. Example: NA B110AA-DN2 → NA B110AA-DM0.2

# NA-NB series modular metal pre-wired switches

Contact type R = snap action L = slow action	External gasket		External gasket		With Ø 20 mm steel roller with self-lubrication or 316L stainless steel on request		With Ø 20 mm steel roller with self-lubrication or 316L stainless steel on request	
Contact block								
B11 R	NA B110HE-DN2	1NO+1NC	NA B110HH-DN2	1NO+1NC	NA B112KA-DN2	1NO+1NC	NA B112KB-DN2	1NO+1NC
B02 R	NA B020HE-DN2	2NC	NA B020HH-DN2	2NC	NA B022KA-DN2	2NC	NA B022KB-DN2	2NC
B12 R	NA B120HE-DN2	1NO+2NC	NA B120HH-DN2	1NO+2NC	NA B122KA-DN2	1NO+2NC	NA B122KB-DN2	1NO+2NC
B22 R	NA B220HE-DN2	2NO+2NC	NA B220HH-DN2	2NO+2NC	NA B222KA-DN2	2NO+2NC	NA B222KB-DN2	2NO+2NC
G11 L	/	/	/	/	NA G112KA-DN2	1NO+1NC	NA G112KB-DN2	1NO+1NC
G02 L	NA G020HE-DN2	2NC	NA G020HH-DN2	2NC	NA G022KA-DN2	2NC	NA G022KB-DN2	2NC
G12 L	/	/	/	/	NA G122KA-DN2	1NO+2NC	NA G122KB-DN2	1NO+2NC
G22 L	/	/	/	/	NA G222KA-DN2	2NO+2NC	NA G222KB-DN2	2NO+2NC
Max. speed	1 m/s		1 m/s		page 235 - type 1		page 235 - type 1	
Actuating force	0.07 Nm		0.03 Nm		0.07 Nm (0.25 Nm)		0.07 Nm (0.25 Nm)	
Travel diagrams	page 236 - group 4		page 236 - group 4		page 236 - group 5		page 236 - group 5	

Contact type R = snap action L = slow action	With steel roller with self-lubrication or 316L stainless steel on request		With steel roller with self-lubrication or 316L stainless steel on request		With steel roller with self-lubrication or 316L stainless steel on request		With steel roller with self-lubrication or 316L stainless steel on request	
Contact block								
B11 R	NA B112KC-DN2	1NO+1NC	NA B112KD-DN2	1NO+1NC	NA B112KE-DN2	1NO+1NC	NA B112KF-DN2	1NO+1NC
B02 R	NA B022KC-DN2	2NC	NA B022KD-DN2	2NC	NA B022KE-DN2	2NC	NA B022KF-DN2	2NC
B12 R	NA B122KC-DN2	1NO+2NC	NA B122KD-DN2	1NO+2NC	NA B122KE-DN2	1NO+2NC	NA B122KF-DN2	1NO+2NC
B22 R	NA B222KC-DN2	2NO+2NC	NA B222KD-DN2	2NO+2NC	NA B222KE-DN2	2NO+2NC	NA B222KF-DN2	2NO+2NC
G11 L	NA G112KC-DN2	1NO+1NC	NA G112KD-DN2	1NO+1NC	NA G112KE-DN2	1NO+1NC	NA G112KF-DN2	1NO+1NC
G02 L	NA G022KC-DN2	2NC	NA G022KD-DN2	2NC	NA G022KE-DN2	2NC	NA G022KF-DN2	2NC
G12 L	NA G122KC-DN2	1NO+2NC	NA G122KD-DN2	1NO+2NC	NA G122KE-DN2	1NO+2NC	NA G122KF-DN2	1NO+2NC
G22 L	NA G222KC-DN2	2NO+2NC	NA G222KD-DN2	2NO+2NC	NA G222KE-DN2	2NO+2NC	NA G222KF-DN2	2NO+2NC
Max. speed	page 235 - type 1		page 235 - type 1		page 235 - type 1		page 235 - type 1	
Actuating force	0.07 Nm (0.25 Nm)		0.07 Nm (0.25 Nm)		0.07 Nm (0.25 Nm)		0.07 Nm (0.25 Nm)	
Travel diagrams	page 236 - group 5		page 236 - group 5		page 236 - group 5		page 236 - group 5	

NB series housing	M12 connector, right	M12 connector, bottom	AMP Superseal 1.5 connector
<b>To order a product of the NB series,</b> replace NA with NB in the codes shown above. Example: NA B110AA-DN2 → NB B110AA-DN2	<b>To order a product with M12 right connector,</b> replace DN2 with DMK in the codes shown above. Example: NA B110AA-DN2 → NA B110AA-DMK	<b>To order a product with M12 bottom connector,</b> replace DN2 with SMK in the codes shown above. Example: NA B110AA-DN2 → NA B110AA-SMK	<b>To order a product with AMP connector,</b> replace DN2 with SAK in the codes shown above. Example: NA B110AA-DN2 → NA B110AA-SAK

All values in the drawings are in mm

Accessories See page 207

→ The 2D and 3D files are available at [www.pizzato.com](http://www.pizzato.com)



Contact type <b>R</b> = snap action <b>L</b> = slow action	With steel roller with self-lubrication or 316L stainless steel on request		With steel roller with self-lubrication or 316L stainless steel on request		With steel roller with self-lubrication or 316L stainless steel on request		Square rod, 3x3 mm, stainless steel	
Contact block								
B11 <b>R</b>	NA B112KG-DN2	1NO+1NC	NA B112KH-DN2	1NO+1NC	NA B112KP-DN2	1NO+1NC	NA B112LB-DN2	1NO+1NC
B02 <b>R</b>	NA B022KG-DN2	2NC	NA B022KH-DN2	2NC	NA B022KP-DN2	2NC	NA B022LB-DN2	2NC
B12 <b>R</b>	NA B122KG-DN2	1NO+2NC	NA B122KH-DN2	1NO+2NC	NA B122KP-DN2	1NO+2NC	NA B122LB-DN2	1NO+2NC
B22 <b>R</b>	NA B222KG-DN2	2NO+2NC	NA B222KH-DN2	2NO+2NC	NA B222KP-DN2	2NO+2NC	NA B222LB-DN2	2NO+2NC
G11 <b>L</b>	NA G112KG-DN2	1NO+1NC	NA G112KH-DN2	1NO+1NC	NA G112KP-DN2	1NO+1NC	NA G112LB-DN2	1NO+1NC
G02 <b>L</b>	NA G022KG-DN2	2NC	NA G022KH-DN2	2NC	NA G022KP-DN2	2NC	NA G022LB-DN2	2NC
G12 <b>L</b>	NA G122KG-DN2	1NO+2NC	NA G122KH-DN2	1NO+2NC	NA G122KP-DN2	1NO+2NC	NA G122LB-DN2	1NO+2NC
G22 <b>L</b>	NA G222KG-DN2	2NO+2NC	NA G222KH-DN2	2NO+2NC	NA G222KP-DN2	2NO+2NC	NA G222LB-DN2	2NO+2NC
Max. speed	page 235 - type 1		page 235 - type 1		page 235 - type 1		1.5 m/s	
Actuating force	0.07 Nm (0.25 Nm $\ominus$ )		0.07 Nm (0.25 Nm $\ominus$ )		0.07 Nm (0.25 Nm $\ominus$ )		0.07 Nm	
Travel diagrams	page 236 - group 5		page 236 - group 5		page 236 - group 5		page 236 - group 5	

Contact type <b>R</b> = snap action <b>L</b> = slow action	Round rod, Ø 3 mm, stainless steel		Glass fibre rod		Porcelain roller			
Contact block								
B11 <b>R</b>	NA B112LE-DN2	1NO+1NC	NA B112LH-DN2	1NO+1NC	NA B112LL-DN2	1NO+1NC	NA B112LP-DN2E24	1NO+1NC
B02 <b>R</b>	NA B022LE-DN2	2NC	NA B022LH-DN2	2NC	NA B022LL-DN2	2NC	NA B022LP-DN2E24	2NC
B12 <b>R</b>	NA B122LE-DN2	1NO+2NC	NA B122LH-DN2	1NO+2NC	NA B122LL-DN2	1NO+2NC	NA B122LP-DN2E24	1NO+2NC
B22 <b>R</b>	NA B222LE-DN2	2NO+2NC	NA B222LH-DN2	2NO+2NC	NA B222LL-DN2	2NO+2NC	NA B222LP-DN2E24	2NO+2NC
G11 <b>L</b>	NA G112LE-DN2	1NO+1NC	NA G112LH-DN2	1NO+1NC	NA G112LL-DN2	1NO+1NC	NA G112LP-DN2E24	1NO+1NC
G02 <b>L</b>	NA G022LE-DN2	2NC	NA G022LH-DN2	2NC	NA G022LL-DN2	2NC	NA G022LP-DN2E24	2NC
G12 <b>L</b>	NA G122LE-DN2	1NO+2NC	NA G122LH-DN2	1NO+2NC	NA G122LL-DN2	1NO+2NC	NA G122LP-DN2E24	1NO+2NC
G22 <b>L</b>	NA G222LE-DN2	2NO+2NC	NA G222LH-DN2	2NO+2NC	NA G222LL-DN2	2NO+2NC	NA G222LP-DN2E24	2NO+2NC
Max. speed	1.5 m/s		1.5 m/s		1.5 m/s		0.5 m/s	
Actuating force	0.07 Nm		0.07 Nm		0.07 Nm		0.04 Nm	
Travel diagrams	page 236 - group 5		page 236 - group 5		page 236 - group 5		page 236 - group 5	

**Cable and M12 connector**

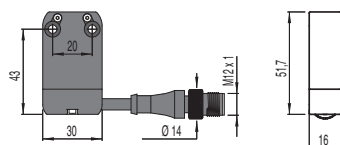

**To order a product with cable and M12 connector:**  
 replace DN2 with DM0.2 in the codes shown above. Example:  
 NA B110AA-DN2 → NA B110AA-DM0.2

Contact type		External gasket		External gasket		External gasket	
<b>R</b> = snap action <b>L</b> = slow action							
Contact block		Contact block		Contact block		Contact block	
B11	<b>R</b> NA B110AB-DN2W5	⊕	1NO+1NC	⊕	1NO+1NC	⊕	1NO+1NC
B02	<b>R</b> NA B020AB-DN2W5	⊕	2NC	⊕	2NC	⊕	2NC
B12	<b>R</b> NA B120AB-DN2W5	⊕	1NO+2NC	⊕	1NO+2NC	⊕	1NO+2NC
B22	<b>R</b> NA B220AB-DN2W5	⊕	2NO+2NC	⊕	2NO+2NC	⊕	2NO+2NC
G11	<b>L</b> NA G110AB-DN2W5	⊕	1NO+1NC	⊕	1NO+1NC	⊕	1NO+1NC
G02	<b>L</b> NA G020AB-DN2W5	⊕	2NC	⊕	2NC	⊕	2NC
G12	<b>L</b> NA G120AB-DN2W5	⊕	1NO+2NC	⊕	1NO+2NC	⊕	1NO+2NC
G22	<b>L</b> NA G220AB-DN2W5	⊕	2NO+2NC	⊕	2NO+2NC	⊕	2NO+2NC
Max. speed	page 235 - type 4		page 235 - type 2		page 235 - type 2		
Actuating force	9.5 N (25 N ⊕)		9.5 N (25 N ⊕)		9.5 N (25 N ⊕)		
Travel diagrams	page 236 - group 1		page 236 - group 1		page 236 - group 1		

Contact type		External gasket		External gasket		External gasket	
<b>R</b> = snap action <b>L</b> = slow action							
Contact block		Contact block		Contact block		Contact block	
B11	<b>R</b> NA B110HB-DN2W5		1NO+1NC		1NO+1NC		1NO+1NC
B02	<b>R</b> NA B020HB-DN2W5		2NC		2NC		2NC
B12	<b>R</b> NA B120HB-DN2W5		1NO+2NC		1NO+2NC		1NO+2NC
B22	<b>R</b> NA B220HB-DN2W5		2NO+2NC		2NO+2NC		2NO+2NC
G11	<b>L</b> /	/		/		/	
G02	<b>L</b> NA G020HB-DN2W5		2NC		2NC		2NC
G12	<b>L</b> /	/		/		/	
G22	<b>L</b> /	/		/		/	
Max. speed	1 m/s		1 m/s		1 m/s		
Actuating force	0.08 Nm		0.12 Nm		0.08 Nm		
Travel diagrams	page 236 - group 4		page 236 - group 4		page 236 - group 4		

NB series housing	M12 connector, right	M12 connector, bottom	AMP Superseal 1.5 connector
<b>To order a product of the NB series,</b> replace NA with NB in the codes shown above. Example: <b>NA B110AA-DN2</b> → <b>NB B110AA-DN2</b>	<b>To order a product with M12 right            connector,</b> replace DN2 with DMK in the codes shown above. Example: <b>NA B110AA-DN2</b> → <b>NA B110AA-DMK</b>	<b>To order a product with M12 bottom            connector,</b> replace DN2 with SMK in the codes shown above. Example: <b>NA B110AA-DN2</b> → <b>NA B110AA-SMK</b>	<b>To order a product with AMP connector,</b> replace DN2 with SAK in the codes shown above. Example: <b>NA B110AA-DN2</b> → <b>NA B110AA-SAK</b>

**Accessories**

 Packs of **10 pcs.**

Article	Description
VN DT1F	Spacer for NA and NF series
VF D16B	Spacer for NB series

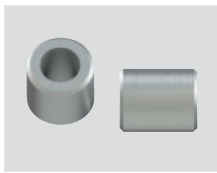

By installing spacers between two switches, it is possible to have 2 or more pre-wired switches, preventing them from slipping.

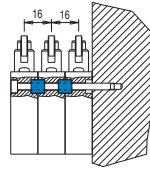
**M12 female connectors with cable**

**Features:**

- Polyurethane connector body
- Class 6 copper conductors acc. to IEC 60228 - mobile installation
- Gold-plated contacts
- Anti-vibration self-locking ring nut made of nickel-plated brass, available on request in AISI 316L stainless steel hex version
- High flexibility cable with oil resistant PVC or PUR sheath suitable to be used in drag chains, acc. to IEC 60332-1-2

**Code structure**
**Attention!** The feasibility of a code number does not mean the effective availability of a product. Please contact our sales office.

article		options	
<b>VF CA4PD3M</b>		<b>-X</b>	
<b>No. of poles</b>		<b>Connection type</b>	
<b>4</b>	4 poles	<b>M</b>	M12x1
<b>5</b>	5 poles	<b>Cable length (L)</b>	
<b>8</b>	8 poles		
<b>12</b>	12 poles	<b>1</b>	1 metre
<b>Cable sheath</b>		<b>2</b>	2 metres
<b>P</b>	PVC (standard)	<b>3</b>	3 metres (standard)
<b>U</b>	PUR	<b>4</b>	4 metres
<b>Connector type</b>		<b>5</b>	5 metres (standard)
<b>D</b>	straight (standard)	<b>...</b>	
<b>G</b>	angled	<b>10</b>	10 metres (standard)
		Other lengths on request.	
		<b>Fixing ring</b>	
			knurled ring (standard)
		<b>X</b>	stainless steel hex ring nut

**Stock items**

VF CA4PD3M
VF CA4PD5M
VF CA4PD10M
VF CA5PD3M
VF CA5PD5M
VF CA5PD10M
VF CA8PD3M
VF CA8PD5M
VF CA8PD10M
VF CA8PD20M
VF CA12PD3M
VF CA12PD5M
VF CA12PD10M
VF CA12PD20M
VF CA12PD30M
VF CA8UD5M-X
VF CA8UD10M-X
VF CA12UD10M-X

**Attention!** For items not in stock the minimum order quantity is 100 pcs.

**Field wireable M12 female connectors**

**General data**

Technopolymer connector body  
 Gold-plated contacts  
 Screw terminals for cable screw fittings

Max. operating voltages	250 Vac/dc (4 and 5-pole) 30 Vac/dc (8-pole)
Maximum current	4 A (4 and 5-pole) 2 A (8-pole)
Protection degree	IP67 acc. to EN 60529
Ambient temperature	-25°C ... +85°C
Wire cross-section	0.25 mm <sup>2</sup> (23 AWG) ... 0.5 mm <sup>2</sup> (20 AWG)
Tightening torque:	0.6 ... 0.8 Nm

Article	Description	no. of poles
VF CBMP4DM04	Field wireable M12 female connector, straight, for Ø 4 ... Ø 6.5 mm multipolar cables	4
VF CBMP5DM04	Field wireable M12 female connector, straight, for Ø 4 ... Ø 6.5 mm multipolar cables	5
VF CBMP8DM04	Field wireable M12 female connector, straight, for Ø 4 ... 7 mm multipolar cables	8

 → The 2D and 3D files are available at [www.pizzato.com](http://www.pizzato.com)

## Selection diagram for item combinations of the NF series

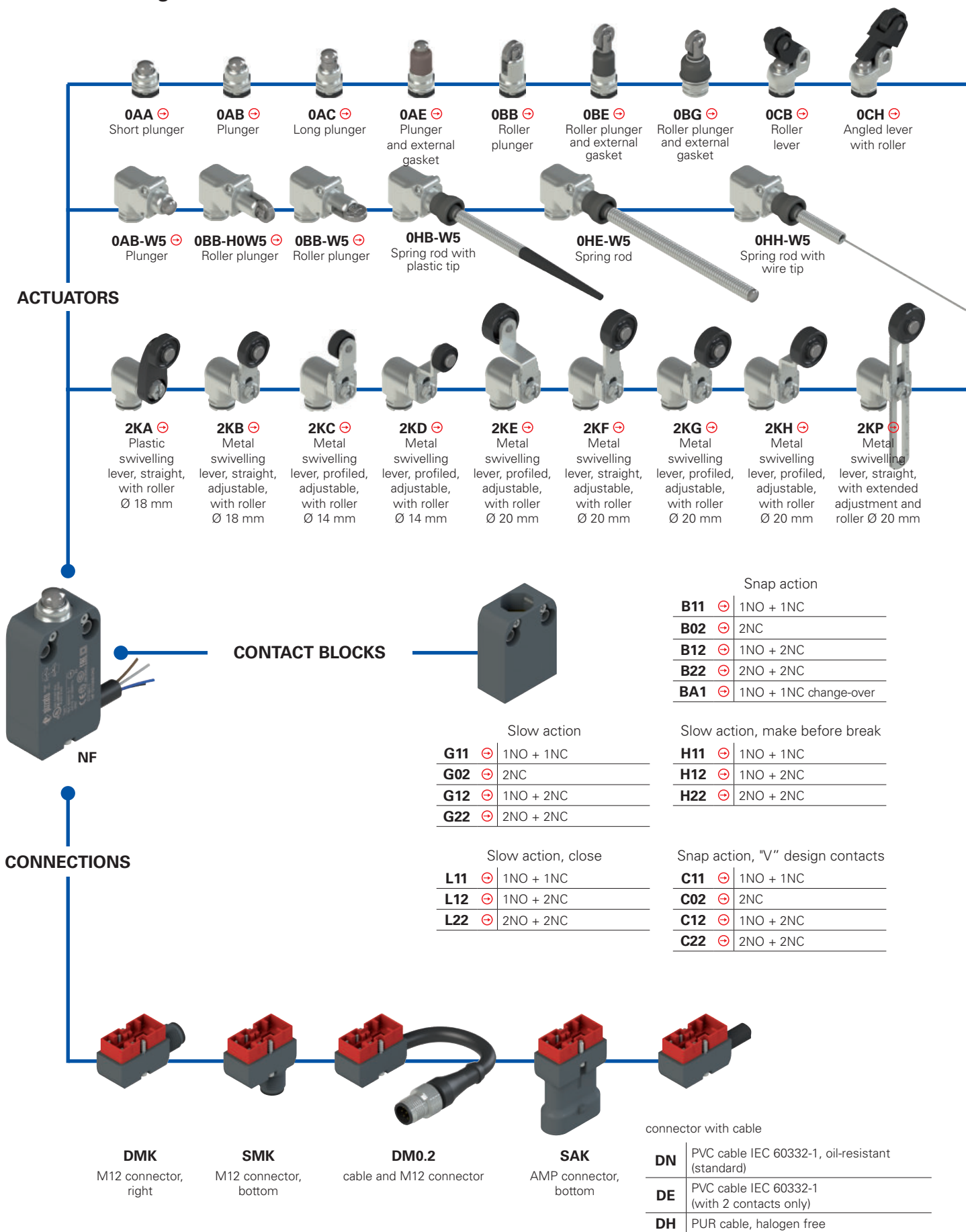

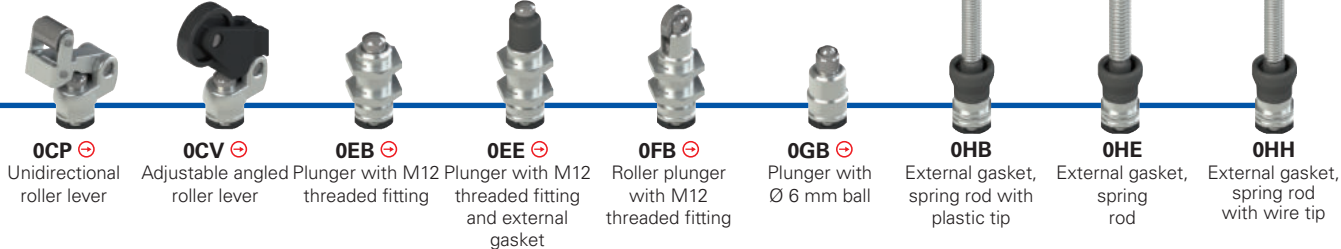

**OCP** ⊖ Unidirectional roller lever  
**OCV** ⊖ Adjustable angled roller lever  
**OEB** ⊖ Plunger with M12 threaded fitting  
**OEE** ⊖ Plunger with M12 threaded fitting and external gasket  
**OFB** ⊖ Roller plunger with M12 threaded fitting  
**OGB** ⊖ Plunger with Ø 6 mm ball  
**OHB** External gasket, spring rod tip with plastic tip  
**OHE** External gasket, spring rod  
**OHH** External gasket, spring rod with wire tip

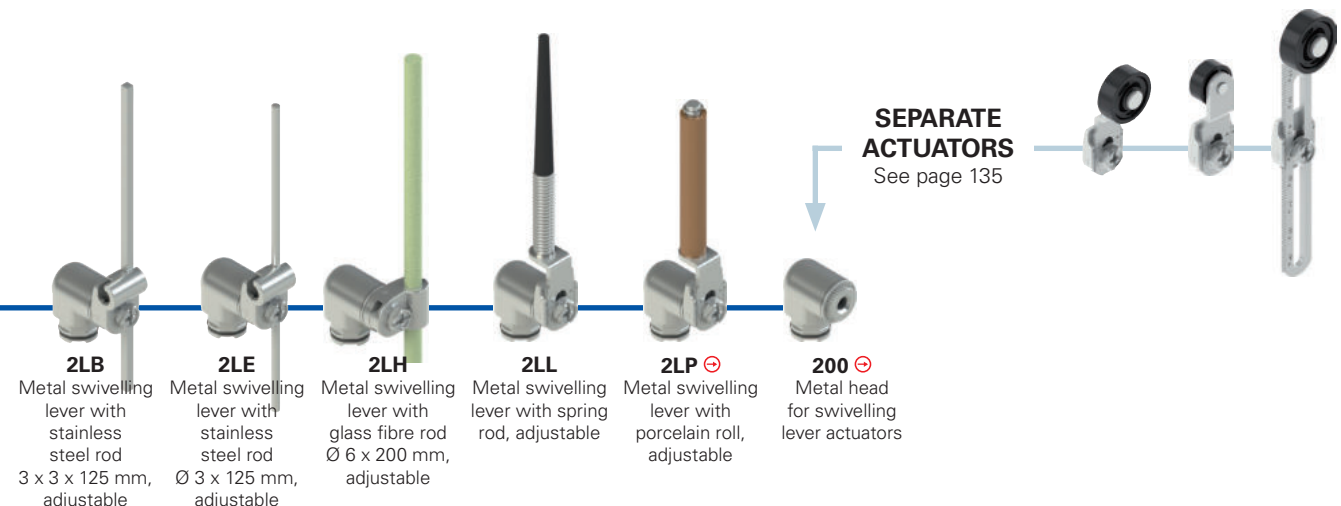

**2LB** Metal swivelling lever with stainless steel rod  
3 x 3 x 125 mm, adjustable  
**2LE** Metal swivelling lever with stainless steel rod  
Ø 3 x 125 mm, adjustable  
**2LH** Metal swivelling lever with glass fibre rod  
Ø 6 x 200 mm, adjustable  
**2LL** Metal swivelling lever with spring rod, adjustable  
**2LP** ⊖ Metal swivelling lever with porcelain roll, adjustable  
**200** ⊖ Metal head for swivelling lever actuators

**SEPARATE ACTUATORS**  
See page 135



**Code structure**

**Attention!** The feasibility of a code number does not mean the effective availability of a product. Please contact our sales office.

article options

**NF B110AB-DN2 GR7T6W5**

**Housing**  
**NF** technopolymer, hole spacing 20 mm

Contact block	
<b>B11</b>	1NO+1NC, snap action (standard)
<b>B02</b>	2NC, snap action (standard)
<b>B12</b>	1NO+2NC, snap action (standard)
<b>B22</b>	2NO+2NC, snap action (standard)
<b>BA1</b>	1NO+1NC, snap action, change-over (available with M connector only)
<b>C11</b>	1NO+1NC, snap action, "V" design contacts
<b>C02</b>	2NC, snap action, "V" design contacts
<b>C12</b>	1NO+2NC, snap action, "V" design contacts
<b>C22</b>	2NO+2NC, snap action, "V" design contacts
<b>G11</b>	1NO+1NC, slow action (standard)
<b>G02</b>	2NC, slow action (standard)
<b>G12</b>	1NO+2NC, slow action (standard)
<b>G22</b>	2NO+2NC, slow action
<b>H11</b>	1NO+1NC, slow action, make before break
<b>H12</b>	1NO+2NC, slow action, make before break
<b>H22</b>	2NO+2NC, slow action, make before break
<b>L11</b>	1NO+1NC, slow action, close
<b>L12</b>	1NO+2NC, slow action, close
<b>L22</b>	2NO+2NC, slow action, close

Other contact blocks on request.

Actuator heads	
<b>0</b>	without head
<b>2</b>	head for swivelling lever actuators

Actuators	
<b>AA</b>	short plunger
<b>AB</b>	plunger
...	...

Output direction	
<b>D</b>	cable or connector, right
<b>S</b>	connector, bottom

Redirection	
	without redirection
<b>W5</b>	90° redirection

Ambient temperature	
	-25°C ... +80°C (standard)
<b>T6</b>	-40°C ... +80°C

Rollers	
	standard roller
<b>R30</b>	Steel, with self-lubrication, Ø 10.6 mm
<b>R44</b>	316L stainless steel, Ø 12 mm
<b>R29</b>	Steel, with self-lubrication, Ø 13 mm
<b>R18</b>	technopolymer, Ø 14 mm
<b>R23</b>	Steel, with self-lubrication, Ø 14 mm
<b>R43</b>	316L stainless steel, Ø 14 mm
<b>R36</b>	Steel, with self-lubrication, Ø 16 mm
<b>R7</b>	technopolymer, Ø 18 mm
<b>R22</b>	technopolymer, Ø 20 mm
<b>R24</b>	Steel, with self-lubrication, Ø 20 mm
<b>R41</b>	316L stainless steel, Ø 20 mm
<b>R19</b>	technopolymer, Ø 22 mm
<b>R25</b>	technopolymer, Ø 35 mm

Contact type	
	silver contacts (standard)
<b>G</b>	silver contacts with 1 µm gold coating <sup>(1)</sup>

<sup>(1)</sup> Not available for contact block C••

Connection type	
<b>0.2</b>	cable, length: 0.2 m with M12 connector (available for DM0.2 versions only)
<b>2</b>	cable, length: 2 m (standard)
<b>5</b>	cable, length 5 m (other cable lengths available on request)
<b>K</b>	integrated connector

Cable or connector type	
<b>N</b>	PVC cable IEC 60332-1, oil-resistant (standard)
<b>E</b>	PVC cable IEC 60332-1 (with 2 contacts only)
<b>H</b>	PUR cable, halogen free
<b>M</b>	M12 connector
<b>A</b>	AMP Superseal 1.5 connector

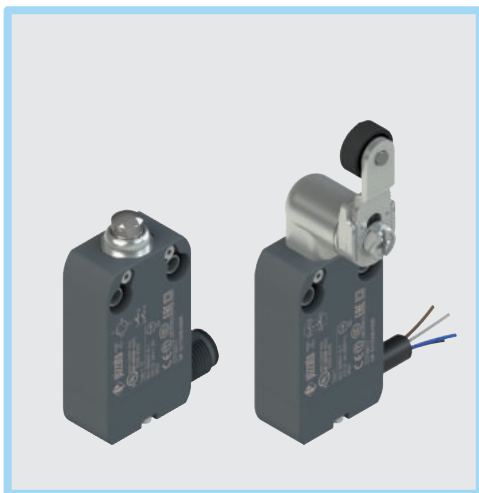

### Main features

- Technopolymer housing, right or bottom cable output
- Protection degrees IP67 and IP69K
- 2 types of integrated cable available
- Versions with M12 connector suitable for safety applications ⊕
- Versions with AMP connector
- 19 contact blocks available
- 37 actuators available

### Quality marks:



IMQ approval:	CA02.04562
UL approval:	E131787
CCC approval:	2021000305000109
EAC approval:	RU C-IT.YT03.B.00035/19

### Technical data

#### Housing

Housing made of glass fibre reinforced technopolymer, self-extinguishing, shock-proof and with double insulation □.

Versions with integrated cable, standard length 2 m. Other lengths 0.5 ... 10 m or special cables available on request.

Versions with integrated M12 connector.

Versions with 0.2 m cable length and M12 connector, other lengths from 0.1 ... 3 m on request

Protection degree:	IP67 acc. to EN 60529
	IP69K acc. to ISO 20653 (Protect the cables from direct high-pressure and high-temperature jets)

Corrosion resistance in saline mist:	≥ 300 hours in NSS acc. to ISO 9227
--------------------------------------	-------------------------------------

#### General data

Ambient temperature for switches without cable: -25°C ... + 80°C (standard)  
-40°C ... + 80°C (T6 option)

Ambient temperature for switches with cable: See table on page 128

Max. actuation frequency: 3600 operating cycles/hour

Mechanical endurance:

B••, G••, H••, L•• contact blocks:	20 million operating cycles
C•• contact block:	5 million operating cycles

Mounting position:

any

Safety parameter B<sub>10D</sub>:

B••, G••, H••, L•• contact blocks:	40,000,000 for NC contacts
C•• contact block:	10,000,000 for NC contacts

Mechanical interlock, not coded:

type 1 acc. to EN ISO 14119

Tightening torques for installation:

see page 235

#### Electrical data

Rated impulse withstand voltage (U <sub>imp</sub> ):	4 kV
Conditional short circuit current:	1000 A acc. to EN 60947-5-1
Pollution degree:	3

#### In compliance with standards:

IEC 60947-5-1, EN 60947-5-1, IEC 60204-1, EN 60204-1, EN ISO 14119, EN ISO 12100, EN 60529, EN IEC 63000, ISO 20653, UL 508, CSA C22.2 No. 14.

#### Compliance with the requirements of:

Low Voltage Directive 2014/35/EU, EMC Directive 2014/30/EU, RoHS Directive 2011/65/EU.

#### Positive contact opening in conformity with standards:

IEC 60947-5-1, EN 60947-5-1.

### ⚠ Installation for safety applications:

Use only switches marked with the ⊕ symbol beside the product code. Always connect the safety circuit to the **NC contacts** (normally closed contacts: see "Internal cable wiring" on page 128) as required by **EN ISO 14119, paragraph 5.4** for specific interlock applications and **EN ISO 13849-2 tables D3** (well-tried components) and **D.8** (fault exclusions) for safety applications in general. Actuate the switch **at least up to the positive opening travel** shown in the travel diagrams on page 236. Actuate the switch **at least with the positive opening force**, reported in brackets below each article, next to the actuating force value. All applicable standards must be respected too.

⚠ **If not expressly indicated in this chapter, for correct installation and utilization of all articles see the instructions given on pages 227 to 242.**

⚠ **Important: Switch off the circuit voltage before disconnecting the connector from the switch. The connector is not suitable for separation of electrical loads.**

### Features approved by IMQ

Rated insulation voltage (U):	250 Vac
Conventional free air thermal current (I <sub>th</sub> ):	10 A (1-2 contacts) / 6 A (2-3 contacts) / 4 A (4 contacts or 4-pole M12 connector)
Protection against short circuits (fuse):	10 A (1-2 contacts) / 6 A (2-3 contacts) / 4 A (4 contacts or 4-pole M12 connector) type gG
Rated impulse withstand voltage (U <sub>imp</sub> ):	4 kV
Protection degree of the housing:	IP67 / IP69K
MA terminals (crimped terminals)	
Pollution degree:	3
Utilization category:	AC15 / DC13 (with connector)
Operating voltage (U <sub>o</sub> ):	250 Vac (50 Hz) / 24 Vdc (with connector)
Operating current (I <sub>o</sub> ):	3 A / 2 A (with connector)

Forms of the contact element: X, Y, X+Y, X+X, Y+Y, Y+Y+X, X+X+Y, X+X+Y+Y, Zb  
Positive opening of contacts on contact blocks B01, B11, B02, B12, B21, B22, G01, G11, G02, G12, G21, G22, L01, L11, L02, L12, L21, L22, H01, H11, H02, H12, H21, H22

In compliance with standards: EN 60947-1, EN 60947-5-1, fundamental requirements of the Low Voltage Directive 2014/35/EU.

Please contact our technical department for the list of approved products.

### Features approved by UL

Electrical Ratings:	R300 pilot duty (28 VA, 125 250 Vdc) B300 pilot duty (360 VA, 120 240 Vac) (1 cont.) B300 pilot duty (360 VA, 120 240 Vac) (2 - 3 cont. without connector) C300 pilot duty (180 VA, 120 240 Vac) (2 - 3 cont. with connector) C300 pilot duty (180 VA, 120 240 Vac) (4 cont.)
Environmental Ratings:	Types 1, 4X, 6, 12, 13 Types 1, 4X "indoor use only" (1 - 2 cont. with "E" type cable)
Screws torque of the detachable connector housing nominal is	0.2 ÷ 0.3 Nm.

Please contact our technical department for the list of approved products.





### Ambient temperatures for switches with cable and electrical data

Connection type	Output with cable						Output with M12 connector		Output with AMP connector
	2 contacts			3 contacts	4 contacts		2 contacts	3 or 4 contacts	2 contacts
	E	N	H	N	N	H	M12 connector, 4-pole	M12 connector, 8-pole	AMP Superseal 1.5 connector
Conductors	4x0.75 mm <sup>2</sup>	4x0.75 mm <sup>2</sup>	4x0.75 mm <sup>2</sup>	6x0.5 mm <sup>2</sup>	8x0.34 mm <sup>2</sup>	8x0.34 mm <sup>2</sup>	4x0.34 mm <sup>2</sup>	8x0.25mm <sup>2</sup>	
Application field	General	General	General, mobile installation	General	General	General, mobile installation	General	General	General
In compliance with standards	H05VV-F	05VV5-F	05EQ-H	03VV-F	03VV-F	03E7Q-H	03VV-H	03VV-H	/
Sheath	PVC	PVC OIL RESISTANT	PUR HALOGEN FREE	PVC OIL RESISTANT	PVC OIL RESISTANT	PUR HALOGEN FREE	PVC OIL RESISTANT	PVC OIL RESISTANT	/
Self-extinguishing	IEC 60332-1-2	IEC 60332-1-2 UL 758:FT1 CEI 20-22 II	IEC60332-1-2 UL 758:FT1	IEC 60332-1-2 UL 758:FT1 CEI 20-22 II	IEC 60332-1-2 UL 758:FT1 CEI 20-22 II	IEC 60332-1-2 UL 758:FT1	IEC60332-1-2 UL 758:FT1 CEI 20-22 II	IEC60332-1-2 UL 758:FT1 CEI 20-22 II	/
Oil resistant	/	UL 758 CSA 22.2 N°210	UL 758 CSA 22.2 N°210	UL 758 CSA 22.2 N°210	UL 758 CSA 22.2 N°210	UL 758 CSA 22.2 N°210	UL 758 CSA 22.2 N°210	UL 758 CSA 22.2 N°210	/
Max. speed	/	/	300 m/min	/	/	300 m/min	50 m/min	50 m/min	/
Max. acceleration	/	/	30 m/s <sup>2</sup>	/	/	30 m/s <sup>2</sup>	5 m/s <sup>2</sup>	5 m/s <sup>2</sup>	/
Minimum bending radius	70 mm	70 mm	70 mm	108 mm	108 mm	70 mm	75 mm	90 mm	/
Outer diameter	7 mm	7 mm	7 mm	7 mm	7 mm	7 mm	6 mm	6 mm	/
End stripped	80mm	80mm	80mm	80mm	80mm	80mm	/	/	/
Copper conductors IEC 60228	Class 5	Class 5	Class 6	Class 5	Class 5	Class 6	Class 6	Class 6	/
Engraving	Standard	6266	6279	6272	6276	6283	6263	6275	/

Ambient temperature with cable extended (T <sub>6</sub> ) standard	Cable, fixed installation	-15°C +60°C	-25°C +80°C	-25°C +80°C	-25°C +80°C	-25°C +80°C	-25°C +80°C	-25°C +80°C	-25°C +80°C	/
	Cable, flexible installation	+5°C +60°C	-5°C +80°C	-25°C +80°C	-5°C +80°C	-5°C +80°C	-25°C +80°C	-15°C +80°C	-15°C +80°C	/
	Cable, mobile installation	/	/	-25°C +80°C	/	/	-25°C +80°C	-15°C +80°C	-15°C +80°C	/
	Cable, fixed installation	/	/	-40°C +80°C	/	/	-40°C +80°C	/	/	/
	Cable, flexible installation	/	/	-40°C +80°C	/	/	-40°C +80°C	/	/	/
	Cable, mobile installation	/	/	-40°C +80°C	/	/	-40°C +80°C	/	/	/

Electrical data	Thermal current I <sub>th</sub>	10 A	10 A	10 A	6 A	3 A	3 A	4 A	2 A	10 A	
	Rated insulation voltage U <sub>i</sub>	250 Vac	250 Vac	250 Vac	250 Vac	250 Vac	250 Vac	250 Vac	250 Vac 300 Vdc	30 Vac 36 Vdc	250 Vac 300 Vdc
	Protection against short circuits (fuse)	10 A 500 V type gG	10 A 500 V type gG	10 A 500 V type gG	6 A 500 V type gG	3 A 500 V type gG	3 A 500 V type gG	4 A 500 V type gG	2 A 500 V type gG	10 A 500 V type gG	
	Utilization category DC13	24 V	2 A	2 A	2 A	2 A	2 A	2 A	2 A	2 A	2 A
		125 V	0.4 A	0.4 A	0.4 A	0.4 A	0.4 A	0.4 A	0.4 A	/	0.4 A
		250 V	0.3 A	0.3 A	0.3 A	0.3 A	0.3 A	0.3 A	0.3 A	/	0.3 A
Utilization category AC15	24 V	4 A	4 A	4 A	4 A	3 A	3 A	4 A	2 A	4 A	
	120 V	4 A	4 A	4 A	4 A	3 A	3 A	4 A	/	4 A	
	250 V	4 A	4 A	4 A	4 A	3 A	3 A	4 A	/	4 A	
Approvals	CE cULus IMQ EAC CCC	CE cULus IMQ EAC CCC	CE cULus EAC	CE cULus IMQ EAC CCC	CE cULus IMQ EAC CCC	CE cULus EAC	CE cULus EAC	CE cULus IMQ EAC CCC	CE cULus EAC	CE cULus EAC CCC	

### Internal cable wiring

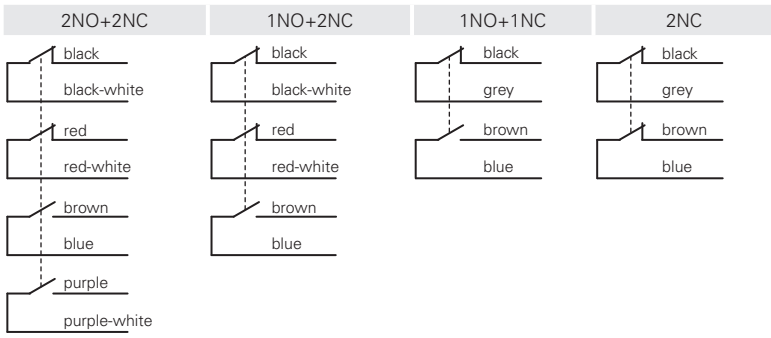

### Connector pin assignment

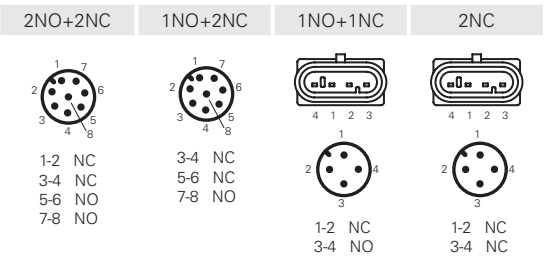

Female connectors see page 210

Contact type					External gasket	
<b>R</b>	= snap action					
<b>L</b>	= slow action					
Contact block						
B11	<b>R</b> NF B110AA-DN2	1NO+1NC	NF B110AB-DN2	1NO+1NC	NF B110AC-DN2	1NO+1NC
B02	<b>R</b> NF B020AA-DN2	2NC	NF B020AB-DN2	2NC	NF B020AC-DN2	2NC
B12	<b>R</b> NF B120AA-DN2	1NO+2NC	NF B120AB-DN2	1NO+2NC	NF B120AC-DN2	1NO+2NC
B22	<b>R</b> NF B220AA-DN2	2NO+2NC	NF B220AB-DN2	2NO+2NC	NF B220AC-DN2	2NO+2NC
G11	<b>L</b> NF G110AA-DN2	1NO+1NC	NF G110AB-DN2	1NO+1NC	NF G110AC-DN2	1NO+1NC
G02	<b>L</b> NF G020AA-DN2	2NC	NF G020AB-DN2	2NC	NF G020AC-DN2	2NC
G12	<b>L</b> NF G120AA-DN2	1NO+2NC	NF G120AB-DN2	1NO+2NC	NF G120AC-DN2	1NO+2NC
G22	<b>L</b> NF G220AA-DN2	2NO+2NC	NF G220AB-DN2	2NO+2NC	NF G220AC-DN2	2NO+2NC
Max. speed	page 235 - type 4		page 235 - type 4		page 235 - type 4	
Actuating force	7 N (25 N ⊕)		7 N (25 N ⊕)		7 N (25 N ⊕)	
Travel diagrams	page 236 - group 1		page 236 - group 1		page 236 - group 1	

Contact type		With 316L stainless steel roller on request	External gasket	External gasket	With steel roller with self-lubrication or 316L stainless steel on request
<b>R</b>	= snap action				
<b>L</b>	= slow action				
Contact block					
B11	<b>R</b> NF B110BB-DN2	1NO+1NC	NF B110BE-DN2	1NO+1NC	NF B110CB-DN2
B02	<b>R</b> NF B020BB-DN2	2NC	NF B020BE-DN2	2NC	NF B020CB-DN2
B12	<b>R</b> NF B120BB-DN2	1NO+2NC	NF B120BE-DN2	1NO+2NC	NF B120CB-DN2
B22	<b>R</b> NF B220BB-DN2	2NO+2NC	NF B220BE-DN2	2NO+2NC	NF B220CB-DN2
G11	<b>L</b> NF G110BB-DN2	1NO+1NC	NF G110BE-DN2	1NO+1NC	NF G110CB-DN2
G02	<b>L</b> NF G020BB-DN2	2NC	NF G020BE-DN2	2NC	NF G020CB-DN2
G12	<b>L</b> NF G120BB-DN2	1NO+2NC	NF G120BE-DN2	1NO+2NC	NF G120CB-DN2
G22	<b>L</b> NF G220BB-DN2	2NO+2NC	NF G220BE-DN2	2NO+2NC	NF G220CB-DN2
Max. speed	page 235 - type 2		page 235 - type 5		page 235 - type 3
Actuating force	7 N (25 N ⊕)		7 N (25 N ⊕)		5 N (25 N ⊕)
Travel diagrams	page 236 - group 1		page 236 - group 1		page 236 - group 2

M12 connector, right

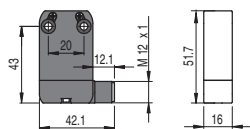

To order a product with M12 right connector, replace DN2 with DMK in the codes shown above.  
 Example:  
 NF B110AA-DN2 → NF B110AA-DMK

M12 connector, bottom

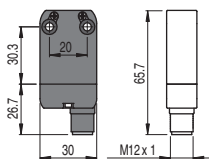

To order a product with M12 bottom connector, replace DN2 with SMK in the codes shown above.  
 Example:  
 NF B110AA-DN2 → NF B110AA-SMK

AMP Superseal 1.5 connector

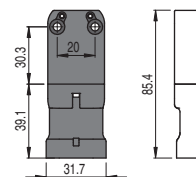

To order a product with AMP connector, replace DN2 with SAK in the codes shown above. Example:  
 NF B110AA-DN2 → NF B110AA-SAK



Contact type	With steel roller with self-lubrication or 316L stainless steel on request		Unidirectional operation		Secured only by means of threaded head	
<b>R</b> = snap action <b>L</b> = slow action						
Max. speed	page 235 - type 3		page 235 - type 3		page 235 - type 4	
Actuating force	5 N (25 N ⊕)		3 N (25 N ⊕)		7 N (25 N ⊕)	
Travel diagrams	page 236 - group 2		page 236 - group 6		page 236 - group 3	

Contact type	Secured only by means of threaded head		Secured only by means of threaded head		Plunger with Ø 6 mm ball		External gasket	
	External gasket		With 316L stainless steel roller on request					
<b>R</b> = snap action <b>L</b> = slow action								
Max. speed	page 235 - type 4		page 235 - type 2		page 235 - type 2		1 m/s	
Actuating force	7 N (25 N ⊕)		7 N (25 N ⊕)		7 N (25 N ⊕)		0.03 Nm	
Travel diagrams	page 236 - group 1		page 236 - group 1		page 236 - group 1		page 236 - group 4	

Cable and M12 connector

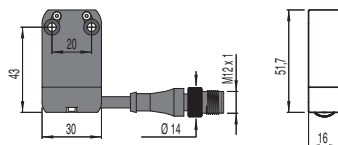

To order a product with cable and M12 connector:  
replace DN2 with DM0.2 in the codes shown above. Example:  
NF B110AA-DN2 → NF B110AA-DM0.2

Contact type	External gasket		External gasket		With Ø 20 mm steel roller with self-lubrication or stainless steel on request		With Ø 20 mm steel roller with self-lubrication or stainless steel on request	
	<b>R</b> = snap action <b>L</b> = slow action							
Contact block								
B11	<b>R</b> NF B110HE-DN2 1NO+1NC	NF B110HH-DN2 1NO+1NC	NF B112KA-DN2 <b>R</b> 1NO+1NC	NF B112KB-DN2 <b>R</b> 1NO+1NC				
B02	<b>R</b> NF B020HE-DN2 2NC	NF B020HH-DN2 2NC	NF B022KA-DN2 <b>R</b> 2NC	NF B022KB-DN2 <b>R</b> 2NC				
B12	<b>R</b> NF B120HE-DN2 1NO+2NC	NF B120HH-DN2 1NO+2NC	NF B122KA-DN2 <b>R</b> 1NO+2NC	NF B122KB-DN2 <b>R</b> 1NO+2NC				
B22	<b>R</b> NF B220HE-DN2 2NO+2NC	NF B220HH-DN2 2NO+2NC	NF B222KA-DN2 <b>R</b> 2NO+2NC	NF B222KB-DN2 <b>R</b> 2NO+2NC				
G11	<b>L</b> /	/	NF G112KA-DN2 <b>R</b> 1NO+1NC	NF G112KB-DN2 <b>R</b> 1NO+1NC				
G02	<b>L</b> NF G020HE-DN2 2NC	NF G020HH-DN2 2NC	NF G022KA-DN2 <b>R</b> 2NC	NF G022KB-DN2 <b>R</b> 2NC				
G12	<b>L</b> /	/	NF G122KA-DN2 <b>R</b> 1NO+2NC	NF G122KB-DN2 <b>R</b> 1NO+2NC				
G22	<b>L</b> /	/	NF G222KA-DN2 <b>R</b> 2NO+2NC	NF G222KB-DN2 <b>R</b> 2NO+2NC				
Max. speed	1 m/s		1 m/s		page 235 - type 1		page 235 - type 1	
Actuating force	0.07 Nm		0.03 Nm		0.07 Nm (0.25 Nm <b>R</b> )		0.07 Nm (0.25 Nm <b>R</b> )	
Travel diagrams	page 236 - group 4		page 236 - group 4		page 236 - group 5		page 236 - group 5	

Contact type	With steel roller with self-lubrication or 316L stainless steel on request		With steel roller with self-lubrication or 316L stainless steel on request		With steel roller with self-lubrication or 316L stainless steel on request		With steel roller with self-lubrication or 316L stainless steel on request	
	<b>R</b> = snap action <b>L</b> = slow action							
Contact block								
B11	<b>R</b> NF B112KC-DN2 <b>R</b> 1NO+1NC	NF B112KD-DN2 <b>R</b> 1NO+1NC	NF B112KE-DN2 <b>R</b> 1NO+1NC	NF B112KF-DN2 <b>R</b> 1NO+1NC				
B02	<b>R</b> NF B022KC-DN2 <b>R</b> 2NC	NF B022KD-DN2 <b>R</b> 2NC	NF B022KE-DN2 <b>R</b> 2NC	NF B022KF-DN2 <b>R</b> 2NC				
B12	<b>R</b> NF B122KC-DN2 <b>R</b> 1NO+2NC	NF B122KD-DN2 <b>R</b> 1NO+2NC	NF B122KE-DN2 <b>R</b> 1NO+2NC	NF B122KF-DN2 <b>R</b> 1NO+2NC				
B22	<b>R</b> NF B222KC-DN2 <b>R</b> 2NO+2NC	NF B222KD-DN2 <b>R</b> 2NO+2NC	NF B222KE-DN2 <b>R</b> 2NO+2NC	NF B222KF-DN2 <b>R</b> 2NO+2NC				
G11	<b>L</b> NF G112KC-DN2 <b>R</b> 1NO+1NC	NF G112KD-DN2 <b>R</b> 1NO+1NC	NF G112KE-DN2 <b>R</b> 1NO+1NC	NF G112KF-DN2 <b>R</b> 1NO+1NC				
G02	<b>L</b> NF G022KC-DN2 <b>R</b> 2NC	NF G022KD-DN2 <b>R</b> 2NC	NF G022KE-DN2 <b>R</b> 2NC	NF G022KF-DN2 <b>R</b> 2NC				
G12	<b>L</b> NF G122KC-DN2 <b>R</b> 1NO+2NC	NF G122KD-DN2 <b>R</b> 1NO+2NC	NF G122KE-DN2 <b>R</b> 1NO+2NC	NF G122KF-DN2 <b>R</b> 1NO+2NC				
G22	<b>L</b> NF G222KC-DN2 <b>R</b> 2NO+2NC	NF G222KD-DN2 <b>R</b> 2NO+2NC	NF G222KE-DN2 <b>R</b> 2NO+2NC	NF G222KF-DN2 <b>R</b> 2NO+2NC				
Max. speed	page 235 - type 1		page 235 - type 1		page 235 - type 1		page 235 - type 1	
Actuating force	0.07 Nm (0.25 Nm <b>R</b> )		0.07 Nm (0.25 Nm <b>R</b> )		0.07 Nm (0.25 Nm <b>R</b> )		0.07 Nm (0.25 Nm <b>R</b> )	
Travel diagrams	page 236 - group 5		page 236 - group 5		page 236 - group 5		page 236 - group 5	

M12 connector, right

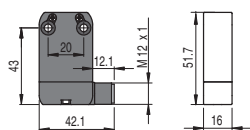

To order a product with M12 right connector, replace DN2 with DMK in the codes shown above.  
Example:  
NF B110AA-DN2 → NF B110AA-DMK

M12 connector, bottom

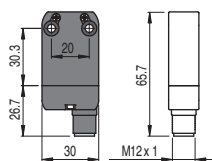

To order a product with M12 bottom connector, replace DN2 with SMK in the codes shown above.  
Example:  
NF B110AA-DN2 → NF B110AA-SMK

AMP Superseal 1.5 connector

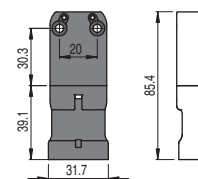

To order a product with AMP connector, replace DN2 with SAK in the codes shown above. Example:  
NF B110AA-DN2 → NF B110AA-SAK



Contact type	With steel roller with self-lubrication or 316L stainless steel on request		With steel roller with self-lubrication or 316L stainless steel on request		With steel roller with self-lubrication or 316L stainless steel on request		Square rod, 3x3 mm, stainless steel			
	<b>R</b> = snap action <b>L</b> = slow action									
Contact block										
B11	<b>R</b>	NF B112KG-DN2	1NO+1NC	NF B112KH-DN2	1NO+1NC	NF B112KP-DN2	1NO+1NC	NF B112LB-DN2	1NO+1NC	
B02	<b>R</b>	NF B022KG-DN2	2NC	NF B022KH-DN2	2NC	NF B022KP-DN2	2NC	NF B022LB-DN2	2NC	
B12	<b>R</b>	NF B122KG-DN2	1NO+2NC	NF B122KH-DN2	1NO+2NC	NF B122KP-DN2	1NO+2NC	NF B122LB-DN2	1NO+2NC	
B22	<b>R</b>	NF B222KG-DN2	2NO+2NC	NF B222KH-DN2	2NO+2NC	NF B222KP-DN2	2NO+2NC	NF B222LB-DN2	2NO+2NC	
G11	<b>L</b>	NF G112KG-DN2	1NO+1NC	NF G112KH-DN2	1NO+1NC	NF G112KP-DN2	1NO+1NC	NF G112LB-DN2	1NO+1NC	
G02	<b>L</b>	NF G022KG-DN2	2NC	NF G022KH-DN2	2NC	NF G022KP-DN2	2NC	NF G022LB-DN2	2NC	
G12	<b>L</b>	NF G122KG-DN2	1NO+2NC	NF G122KH-DN2	1NO+2NC	NF G122KP-DN2	1NO+2NC	NF G122LB-DN2	1NO+2NC	
G22	<b>L</b>	NF G222KG-DN2	2NO+2NC	NF G222KH-DN2	2NO+2NC	NF G222KP-DN2	2NO+2NC	NF G222LB-DN2	2NO+2NC	
Max. speed	page 235 - type 1			page 235 - type 1			page 235 - type 1			1.5 m/s
Actuating force	0.07 Nm (0.25 Nm $\ominus$ )			0.07 Nm (0.25 Nm $\ominus$ )			0.07 Nm (0.25 Nm $\ominus$ )			0.07 Nm
Travel diagrams	page 236 - group 5			page 236 - group 5			page 236 - group 5			page 236 - group 5

Contact type	Round rod, Ø 3 mm, stainless steel		Glass fibre rod				Porcelain roller		
	<b>R</b> = snap action <b>L</b> = slow action								
Contact block									
B11	<b>R</b>	NF B112LE-DN2	1NO+1NC	NF B112LH-DN2	1NO+1NC	NF B112LL-DN2	1NO+1NC	NF B112LP-DN2E24	1NO+1NC
B02	<b>R</b>	NF B022LE-DN2	2NC	NF B022LH-DN2	2NC	NF B022LL-DN2	2NC	NF B022LP-DN2E24	2NC
B12	<b>R</b>	NF B122LE-DN2	1NO+2NC	NF B122LH-DN2	1NO+2NC	NF B122LL-DN2	1NO+2NC	NF B122LP-DN2E24	1NO+2NC
B22	<b>R</b>	NF B222LE-DN2	2NO+2NC	NF B222LH-DN2	2NO+2NC	NF B222LL-DN2	2NO+2NC	NF B222LP-DN2E24	2NO+2NC
G11	<b>L</b>	NF G112LE-DN2	1NO+1NC	NF G112LH-DN2	1NO+1NC	NF G112LL-DN2	1NO+1NC	NF G112LP-DN2E24	1NO+1NC
G02	<b>L</b>	NF G022LE-DN2	2NC	NF G022LH-DN2	2NC	NF G022LL-DN2	2NC	NF G022LP-DN2E24	2NC
G12	<b>L</b>	NF G122LE-DN2	1NO+2NC	NF G122LH-DN2	1NO+2NC	NF G122LL-DN2	1NO+2NC	NF G122LP-DN2E24	1NO+2NC
G22	<b>L</b>	NF G222LE-DN2	2NO+2NC	NF G222LH-DN2	2NO+2NC	NF G222LL-DN2	2NO+2NC	NF G222LP-DN2E24	2NO+2NC
Max. speed	1.5 m/s		1.5 m/s		1.5 m/s		1.5 m/s		0.5 m/s
Actuating force	0.07 Nm		0.07 Nm		0.07 Nm		0.07 Nm		0.04 Nm
Travel diagrams	page 236 - group 5		page 236 - group 5		page 236 - group 5		page 236 - group 5		page 236 - group 5

Cable and M12 connector

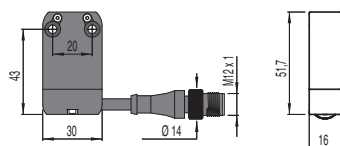

To order a product with cable and M12 connector:  
replace DN2 with DM0.2 in the codes shown above. Example:  
NF B110AA-DN2 → NF B110AA-DM0.2

Contact type										
<b>R</b>	= snap action									
<b>L</b>	= slow action									
Contact block										
B11	<b>R</b>	NF B110AB-DN2W5	⊕	1NO+1NC	NF B110BB-DN2H0W5	⊕	1NO+1NC	NF B110BB-DN2W5	⊕	1NO+1NC
B02	<b>R</b>	NF B020AB-DN2W5	⊕	2NC	NF B020BB-DN2H0W5	⊕	2NC	NF B020BB-DN2W5	⊕	2NC
B12	<b>R</b>	NF B120AB-DN2W5	⊕	1NO+2NC	NF B120BB-DN2H0W5	⊕	1NO+2NC	NF B120BB-DN2W5	⊕	1NO+2NC
B22	<b>R</b>	NF B220AB-DN2W5	⊕	2NO+2NC	NF B220BB-DN2H0W5	⊕	2NO+2NC	NF B220BB-DN2W5	⊕	2NO+2NC
G11	<b>L</b>	NF G110AB-DN2W5	⊕	1NO+1NC	NF G110BB-DN2H0W5	⊕	1NO+1NC	NF G110BB-DN2W5	⊕	1NO+1NC
G02	<b>L</b>	NF G020AB-DN2W5	⊕	2NC	NF G020BB-DN2H0W5	⊕	2NC	NF G020BB-DN2W5	⊕	2NC
G12	<b>L</b>	NF G120AB-DN2W5	⊕	1NO+2NC	NF G120BB-DN2H0W5	⊕	1NO+2NC	NF G120BB-DN2W5	⊕	1NO+2NC
G22	<b>L</b>	NF G220AB-DN2W5	⊕	2NO+2NC	NF G220BB-DN2H0W5	⊕	2NO+2NC	NF G220BB-DN2W5	⊕	2NO+2NC
Max. speed	page 235 - type 4		page 235 - type 2		page 235 - type 2					
Actuating force	9.5 N (25 N ⊕)		9.5 N (25 N ⊕)		9.5 N (25 N ⊕)					
Travel diagrams	page 236 - group 1		page 236 - group 1		page 236 - group 1					

Contact type		External gasket		External gasket		External gasket	
<b>R</b>	= snap action						
<b>L</b>	= slow action						
Contact block							
B11	<b>R</b>	NF B110HB-DN2W5	1NO+1NC	NF B110HE-DN2W5	1NO+1NC	NF B110HH-DN2W5	1NO+1NC
B02	<b>R</b>	NF B020HB-DN2W5	2NC	NF B020HE-DN2W5	2NC	NF B020HH-DN2W5	2NC
B12	<b>R</b>	NF B120HB-DN2W5	1NO+2NC	NF B120HE-DN2W5	1NO+2NC	NF B120HH-DN2W5	1NO+2NC
B22	<b>R</b>	NF B220HB-DN2W5	2NO+2NC	NF B220HE-DN2W5	2NO+2NC	NF B220HH-DN2W5	2NO+2NC
G11	<b>L</b>	/	/	/	/	/	/
G02	<b>L</b>	NF G020HB-DN2W5	2NC	NF G020HE-DN2W5	2NC	NF G020HH-DN2W5	2NC
G12	<b>L</b>	/	/	/	/	/	/
G22	<b>L</b>	/	/	/	/	/	/
Max. speed	1 m/s		1 m/s		1 m/s		
Actuating force	0.08 Nm		0.12 Nm		0.08 Nm		
Travel diagrams	page 236 - group 4		page 236 - group 4		page 236 - group 4		

M12 connector, right

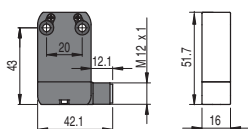

To order a product with M12 right connector, replace DN2 with DMK in the codes shown above.  
Example:  
NF B110AA-DN2 → NF B110AA-DMK

M12 connector, bottom

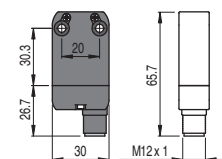

To order a product with M12 bottom connector, replace DN2 with SMK in the codes shown above.  
Example:  
NF B110AA-DN2 → NF B110AA-SMK

AMP Superseal 1.5 connector

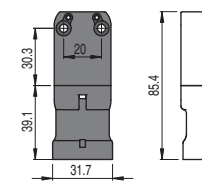

To order a product with AMP connector, replace DN2 with SAK in the codes shown above. Example:  
NF B110AA-DN2 → NF B110AA-SAK

**Accessories** Packs of **10 pcs.**

Article	Description
VN DT1F	Spacer for NA and NF series

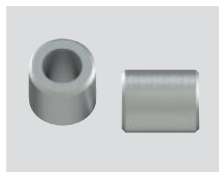

By installing spacers between two switches, it is possible to have 2 or more pre-wired switches, preventing them from slipping.

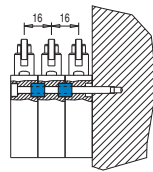
**M12 female connectors with cable**

**Features:**

- Polyurethane connector body
- Class 6 copper conductors acc. to IEC 60228 - mobile installation
- Gold-plated contacts
- Anti-vibration self-locking ring nut made of nickel-plated brass, available on request in AISI 316L stainless steel hex version
- High flexibility cable with oil resistant PVC or PUR sheath suitable to be used in drag chains, acc. to IEC 60332-1-2

**Code structure** **Attention!** The feasibility of a code number does not mean the effective availability of a product. Please contact our sales office.

article options  
**VF CA4PD3M-X**

No. of poles	
<b>4</b>	4 poles
<b>5</b>	5 poles
<b>8</b>	8 poles
<b>12</b>	12 poles

Cable sheath	
<b>P</b>	PVC (standard)
<b>U</b>	PUR

Connector type	
<b>D</b>	straight (standard)
<b>G</b>	angled

Connection type	
<b>M</b>	M12x1

Fixing ring	
	knurled ring (standard)
<b>X</b>	stainless steel hex ring nut

Cable length (L)	
<b>1</b>	1 metre
<b>2</b>	2 metres
<b>3</b>	3 metres (standard)
<b>4</b>	4 metres
<b>5</b>	5 metres (standard)
...	
<b>10</b>	10 metres (standard)

Other lengths on request.

**Stock items**

- VF CA4PD3M
- VF CA4PD5M
- VF CA4PD10M
- VF CA5PD3M
- VF CA5PD5M
- VF CA5PD10M
- VF CA8PD3M
- VF CA8PD5M
- VF CA8PD10M
- VF CA8PD20M
- VF CA12PD3M
- VF CA12PD5M
- VF CA12PD10M
- VF CA12PD20M
- VF CA12PD30M
- VF CA8UD5M-X
- VF CA8UD10M-X
- VF CA12UD10M-X

**Attention!** For items not in stock the minimum order quantity is 100 pcs.

**Field wireable M12 female connectors**

**General data**

Technopolymer connector body  
 Gold-plated contacts  
 Screw terminals for cable screw fittings

Max. operating voltages	250 Vac/dc (4 and 5-pole) 30 Vac/dc (8-pole)
Maximum current	4 A (4 and 5-pole) 2 A (8-pole)
Protection degree	IP67 acc. to EN 60529
Ambient temperature	-25°C ... +85°C
Wire cross-section	0.25 mm <sup>2</sup> (23 AWG) ... 0.5 mm <sup>2</sup> (20 AWG)
Tightening torque:	0.6 ... 0.8 Nm

Article	Description	no. of poles
VF CBMP4DM04	Field wireable M12 female connector, straight, for Ø 4 ... Ø 6.5 mm multipolar cables	4
VF CBMP5DM04	Field wireable M12 female connector, straight, for Ø 4 ... Ø 6.5 mm multipolar cables	5
VF CBMP8DM04	Field wireable M12 female connector, straight, for Ø 4 ... 7 mm multipolar cables	8

→ The 2D and 3D files are available at [www.pizzato.com](http://www.pizzato.com)

## Selection diagram for item combinations of the NA, NB, NF series

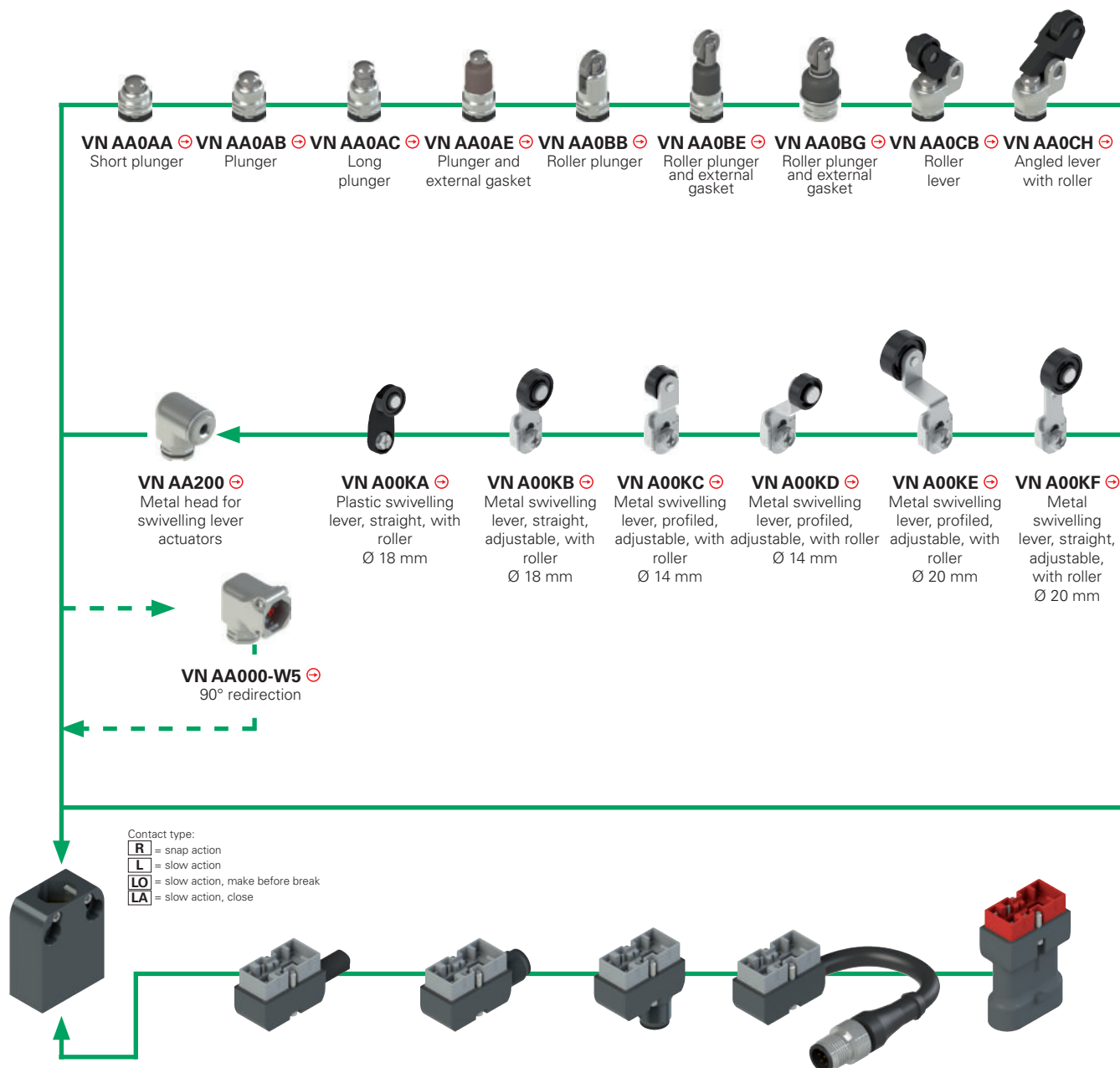

METAL housing, NA hole spacing 20 mm	Metal connector with cable	Cable length (m)	M12 metal connector, right	M12 metal connector, bottom	Metal connector with cable and M12 connector	Cable length (m)	AMP technopolymer connector, bottom
NA B11000 ⊕ 1NO+1NC <b>R</b>	VN CM11DN2	2	VN CM11DMK	VN CM11SMK	VN CM11DM0.2	0.2	VN CM11SAK
NA G11000 ⊕ 1NO+1NC <b>L</b>		5					
NA L11000 ⊕ 1NO+1NC <b>LA</b>	VN CM11DN5	2	VN CM11DMK	VN CM11SMK	VN CM11DM0.2	0.2	VN CM11SAK
NA H11000 ⊕ 1NO+1NC <b>LO</b>		5					
NA B02000 ⊕ 2NC <b>R</b>	VN CM02DN2	2	VN CM02DMK	VN CM02SMK	VN CM02DM0.2	0.2	VN CM02SAK
NA G02000 ⊕ 2NC <b>L</b>		5					
NA B20000 ⊕ 2NO <b>R</b>	VN CM20DN2	2	VN CM20DMK	VN CM20SMK	VN CM20DM0.2	0.2	VN CM20SAK
NA G20000 ⊕ 2NO <b>L</b>		5					
NA B12000 ⊕ 1NO+2NC <b>R</b>	VN CM12DN2	2	VN CM12DMK	VN CM12SMK	VN CM12DM0.2	0.2	VN CM12SAK
NA G12000 ⊕ 1NO+2NC <b>L</b>		5					
NA L12000 ⊕ 1NO+2NC <b>LA</b>	VN CM12DN5	2	VN CM12DMK	VN CM12SMK	VN CM12DM0.2	0.2	VN CM12SAK
NA H12000 ⊕ 1NO+2NC <b>LO</b>		5					
NA B22000 ⊕ 2NO+2NC <b>R</b>	VN CM22DN2	2	VN CM22DMK	VN CM22SMK	VN CM22DM0.2	0.2	VN CM22SAK
NA G22000 ⊕ 2NO+2NC <b>L</b>		5					
NA L22000 ⊕ 2NO+2NC <b>LA</b>	VN CM22DN5	2	VN CM22DMK	VN CM22SMK	VN CM22DM0.2	0.2	VN CM22SAK
NA H22000 ⊕ 2NO+2NC <b>LO</b>		5					

To order a NB series housing, replace NA with NB in the codes shown above. Example:  
NA B11000 → NB B11000

⚠ It is not allowed to install VN CM\*\*\*\*\* connectors on technopolymer housings



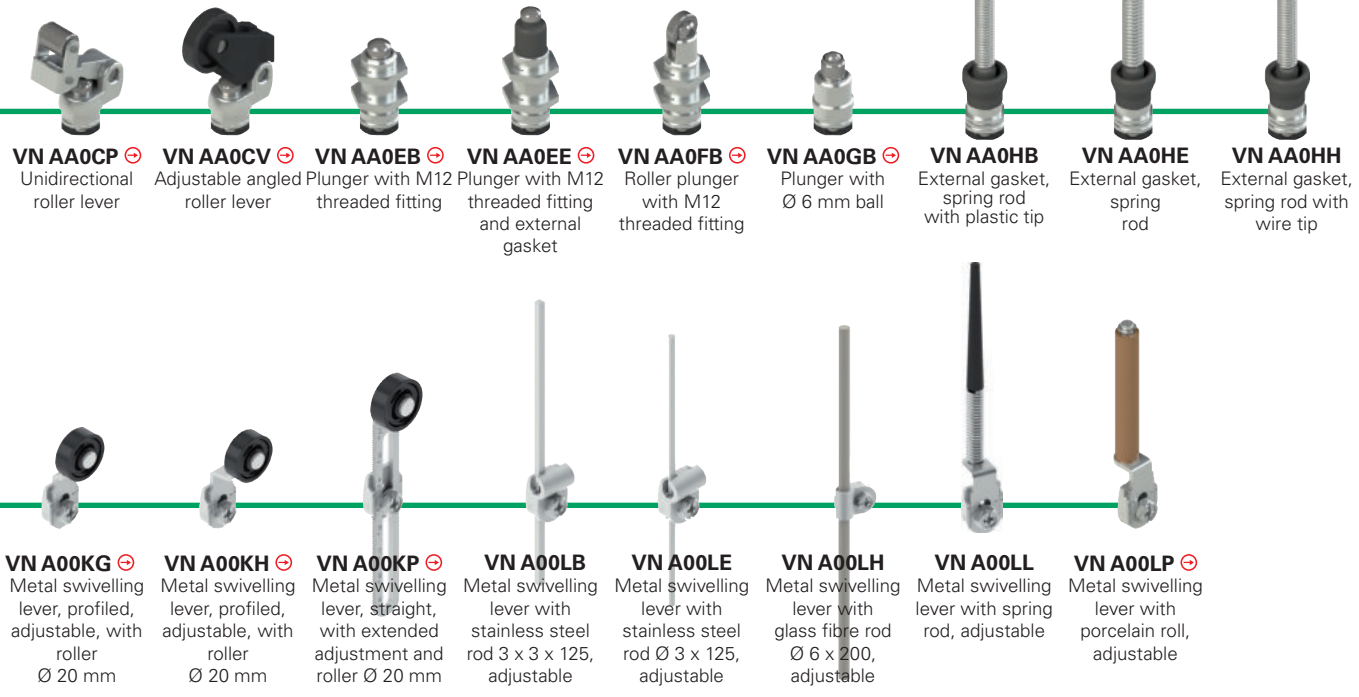

**VN AA0CP** ⊕ Unidirectional roller lever  
**VN AA0CV** ⊕ Adjustable angled roller lever  
**VN AA0EB** ⊕ Plunger with M12 threaded fitting  
**VN AA0EE** ⊕ Plunger with M12 threaded fitting and external gasket  
**VN AA0FB** ⊕ Roller plunger with M12 threaded fitting  
**VN AA0GB** ⊕ Plunger with Ø 6 mm ball  
**VN AA0HB** External gasket, spring rod with plastic tip  
**VN AA0HE** External gasket, spring rod  
**VN AA0HH** External gasket, spring rod with wire tip

**VN A00KG** ⊕ Metal swivelling lever, profiled, adjustable, with roller Ø 20 mm  
**VN A00KH** ⊕ Metal swivelling lever, profiled, adjustable, with roller Ø 20 mm  
**VN A00KP** ⊕ Metal swivelling lever, straight, with extended adjustment and roller Ø 20 mm  
**VN A00LB** Metal swivelling lever with stainless steel rod 3 x 3 x 125, adjustable  
**VN A00LE** Metal swivelling lever with stainless steel rod Ø 3 x 125, adjustable  
**VN A00LH** Metal swivelling lever with glass fibre rod Ø 6 x 200, adjustable  
**VN A00LL** Metal swivelling lever with spring rod, adjustable  
**VN A00LP** ⊕ Metal swivelling lever with porcelain roll, adjustable

Contact type:  
**R** = snap action  
**L** = slow action  
**LO** = slow action, make before break  
**LA** = slow action, close

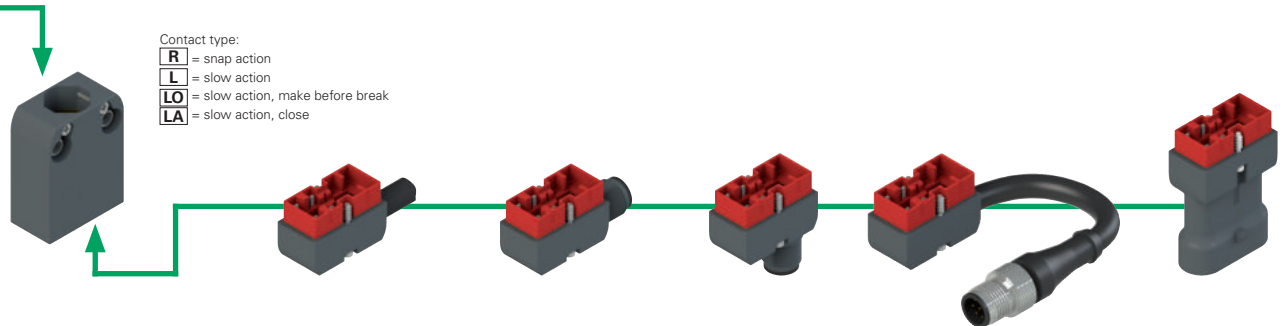

NF TECHNOPOLYMER housing, 20 mm hole spacing	Technopolymer connector with cable	Cable length (m)	M12 technopolymer connector, right	M12 technopolymer connector, bottom	Technopolymer connector with cable and M12 connector	Cable length (m)	AMP technopolymer connector, bottom
NF B11000 ⊕ 1NO+1NC <b>R</b>	VN CP11DN2	2	VN CP11DMK	VN CP11SMK	VN CP11DM0.2	0.2	VN CP11SAK
NF G11000 ⊕ 1NO+1NC <b>L</b>	VN CP11DN5	5					
NF L11000 ⊕ 1NO+1NC <b>LA</b>	VN CP02DN2	2	VN CP02DMK	VN CP02SMK	VN CP02DM0.2	0.2	VN CP02SAK
NF H11000 ⊕ 1NO+1NC <b>LO</b>	VN CP02DN5	5					
NF B02000 ⊕ 2NC <b>R</b>	VN CP20DN2	2	VN CP20DMK	VN CP20SMK	VN CP20DM0.2	0.2	VN CP20SAK
NF G02000 ⊕ 2NC <b>L</b>	VN CP20DN5	5					
NF B20000 ⊕ 2NO <b>R</b>	VN CP12DN2	2	VN CP12DMK	VN CP12SMK	VN CP12DM0.2	0.2	
NF G20000 ⊕ 2NO <b>L</b>	VN CP12DN5	5					
NF B22000 ⊕ 2NO+2NC <b>R</b>	VN CP22DN2	2	VN CP22DMK	VN CP22SMK	VN CP22DM0.2	0.2	
NF G22000 ⊕ 2NO+2NC <b>L</b>	VN CP22DN5	5					
NF L22000 ⊕ 2NO+2NC <b>LA</b>							
NF H22000 ⊕ 2NO+2NC <b>LO</b>							

⚠ It is not allowed to install VN CP\*\*\*\*\* connectors on metal housings

Housings

Contact type:  
**R** = snap action  
**L** = slow action  
**LO** = slow action, make before break  
**LA** = slow action, close

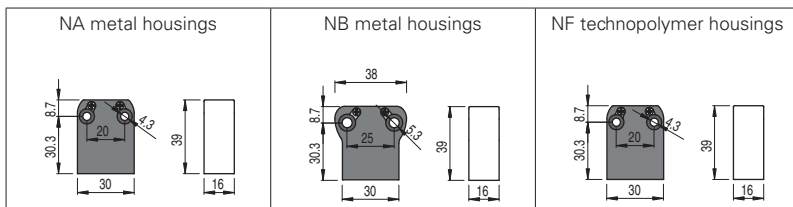

<b>R</b>	NA B11000	⊕	1NO+1NC	<b>NB B11000</b>	⊕	1NO+1NC	<b>NF B11000</b>	⊕	1NO+1NC
<b>L</b>	NA G11000	⊕	1NO+1NC	<b>NB G11000</b>	⊕	1NO+1NC	<b>NF G11000</b>	⊕	1NO+1NC
<b>LA</b>	NA L11000	⊕	1NO+1NC	<b>NB L11000</b>	⊕	1NO+1NC	<b>NF L11000</b>	⊕	1NO+1NC
<b>LO</b>	NA H11000	⊕	1NO+1NC	<b>NB H11000</b>	⊕	1NO+1NC	<b>NF H11000</b>	⊕	1NO+1NC
<b>R</b>	NA B12000	⊕	1NO+2NC	<b>NB B12000</b>	⊕	1NO+2NC	<b>NF B12000</b>	⊕	1NO+2NC
<b>L</b>	NA G12000	⊕	1NO+2NC	<b>NB G12000</b>	⊕	1NO+2NC	<b>NF G12000</b>	⊕	1NO+2NC
<b>LA</b>	NA L12000	⊕	1NO+2NC	<b>NB L12000</b>	⊕	1NO+2NC	<b>NF L12000</b>	⊕	1NO+2NC
<b>LO</b>	NA H12000	⊕	1NO+2NC	<b>NB H12000</b>	⊕	1NO+2NC	<b>NF H12000</b>	⊕	1NO+2NC
<b>R</b>	NA B22000	⊕	2NO+2NC	<b>NB B22000</b>	⊕	2NO+2NC	<b>NF B22000</b>	⊕	2NO+2NC
<b>L</b>	NA G22000	⊕	2NO+2NC	<b>NB G22000</b>	⊕	2NO+2NC	<b>NF G22000</b>	⊕	2NO+2NC
<b>LA</b>	NA L22000	⊕	2NO+2NC	<b>NB L22000</b>	⊕	2NO+2NC	<b>NF L22000</b>	⊕	2NO+2NC
<b>LO</b>	NA H22000	⊕	2NO+2NC	<b>NB H22000</b>	⊕	2NO+2NC	<b>NF H22000</b>	⊕	2NO+2NC

Quality marks:



Connectors with cable

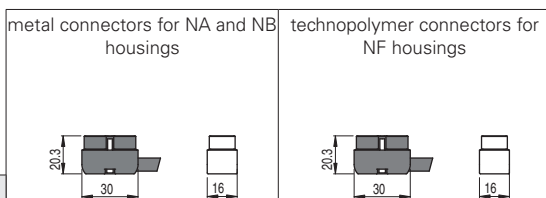

Cable type	Length (m)	metal connectors for NA and NB housings	technopolymer connectors for NF housings
N PVC	2	VN CM11DN2 1NO+1NC	VN CP11DN2 1NO+1NC
	5	VN CM11DN5 1NO+1NC	VN CP11DN5 1NO+1NC
	2	VN CM12DN2 1NO+2NC	VN CP12DN2 1NO+2NC
	5	VN CM12DN5 1NO+2NC	VN CP12DN5 1NO+2NC
	2	VN CM22DN2 2NO+2NC	VN CP22DN2 2NO+2NC
	5	VN CM22DN5 2NO+2NC	VN CP22DN5 2NO+2NC
H PUR halogen free	2	VN CM11DH2 1NO+1NC	VN CP11DH2 1NO+1NC
	5	VN CM11DH5 1NO+1NC	VN CP11DH5 1NO+1NC
	2	VN CM12DH2 1NO+2NC	VN CP22DH2 2NO+2NC
	5	VN CM12DH5 1NO+2NC	VN CP22DH5 2NO+2NC

Other cable lengths on request

M12 connectors

metal connectors for NA and NB housings

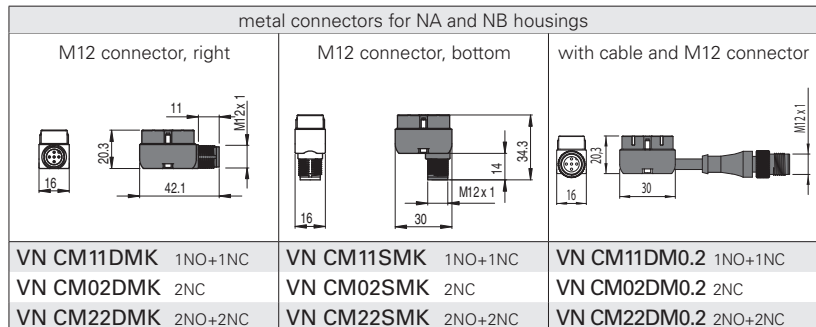

metal connectors for NA and NB housings			technopolymer connectors for NF housings		
VN CM11DMK	1NO+1NC	VN CM11SMK	1NO+1NC	VN CP11DMK	1NO+1NC
VN CM02DMK	2NC	VN CM02SMK	2NC	VN CP02DMK	2NC
VN CM22DMK	2NO+2NC	VN CM22SMK	2NO+2NC	VN CP22DMK	2NO+2NC
VN CM11DM0.2	1NO+1NC	VN CM02DM0.2	2NC	VN CP11DM0.2	1NO+1NC
VN CM02DM0.2	2NC	VN CM22DM0.2	2NO+2NC	VN CP02DM0.2	2NC
VN CM22DM0.2	2NO+2NC			VN CP22DM0.2	2NO+2NC

AMP connectors

technopolymer connectors for NA and NB housings

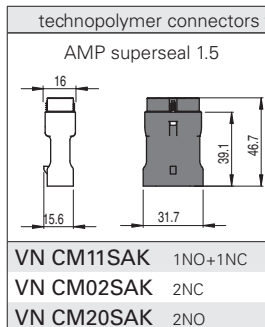

technopolymer connectors for NA and NB housings		technopolymer connectors for NF housings	
VN CM11SAK	1NO+1NC	VN CP11SAK	1NO+1NC
VN CM02SAK	2NC	VN CP02SAK	2NC
VN CM20SAK	2NO	VN CP20SAK	2NO

**Important:** Always check that the applied electric load is within the voltage and current limits defined for the connectors. See tables on page 118 and 128.

All values in the drawings are in mm

Accessories See page 207

→ The 2D and 3D files are available at [www.pizzato.com](http://www.pizzato.com)



# Actuators

VN AA0AA	VN AA0AB	VN AA0AC	VN AA0AE	VN AA0BB	VN AA0BE
VN AA0BG	VN AA0CB	VN AA0CH	VN AA0CP	VN AA0CV	VN AA0EB
VN AA0EE	VN AA0FB	VN AA0GB	VN AA0HB	VN AA0HE	VN AA0HH

# Levers

ATTENTION: These separate actuators can be used only with items of the NA, NB and NF series.

VN A00KA	VN A00KB	VN A00KC	VN A00KD	VN A00KE	VN A00KF
VN A00KG	VN A00KH	VN A00KP	VN A00LB	VN A00LE	VN A00LH
VN A00LL	VN A00LP	VN A00KB-V38	VN A00KE-V38	VN A00KG-V38	VN A00KP-V38

# Heads

VN AA200

# 90° redirection

VN AA000-W5

All values in the drawings are in mm

Accessories See page 207

The 2D and 3D files are available at [www.pizzato.com](http://www.pizzato.com)

## Description



The microswitches of MK series have been designed to add new features to traditional and tested microswitches by Pizzato Elettrica.

The absolute new feature of this series is the enhanced and state-of-the-art trigger mechanism, whose design features are of higher quality in comparison to other solutions available on the market.

Thanks to the double and redundant execution, the electrical contact of the microswitch has been designed with a technology providing increased reliability, and is able to carry out switching operations with positive opening. Inside the housing of the microswitch it is possible to insert gaskets to protect the mechanism against fine dusts or liquids up to the protection degree IP65. Conductor fixing terminals are more practical, allowing for cables of different diameters to be fixed or the choice of different bends for the Faston contacts.

## Contact reliability

In the following table a typical contact structure for a microswitch normally used in the industry (type A) is shown compared with the solution implemented by Pizzato Elettrica in the MK series microswitches: mobile contact with single interruption and double contacts (type B). As you can see from the table below, in the latter contact structure (type B) the contact resistance (R) is only half in comparison to the mobile contact with single interruption (type A), and presents a very low failure probability (fe) as well.

With a failure probability of x for a single switching operation, the failure probability for type A is  $fe=x$ , for type B  $fe \approx x^2$ . This means that if the probability of a switching failure is x in a given situation, e.g.,  $1 \times 10^{-4}$ , (1 switching failure in 10,000), the result is as follows:

- for type A one failed commutation every 10,000.
- for type B one failed commutation every 100,000,000.

Type	Diagram	Description	Contact resistance R	Probability of errors fe
A Common micro-switch		mobile contact with single interruption	$R=R_c$	$fe=x$
B Pizzato's micro-switch MK series		mobile contact with single interruption and double contacts	$R=R_c/2$	$fe \approx x^2$

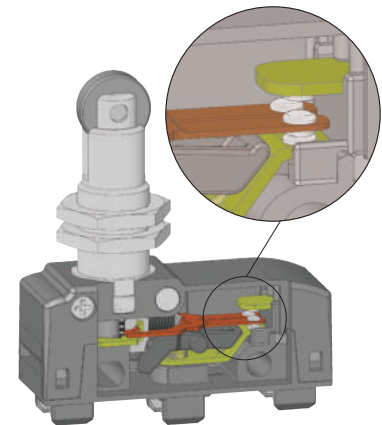

## Extended temperature range

# -40°C

The MK series includes versions with extended temperature range available upon request. Compared to the standard MK microswitches with temperature ranges from -25 °C to +85 °C, these special versions are suitable for environments with temperature ranges from -40 °C to +85 °C. They can therefore be installed inside cold stores, sterilizers or other equipment with very low ambient temperature. The special materials used to produce these versions retain their characteristics even under these conditions, thereby expanding the installation possibilities.

## Microswitches for safety applications

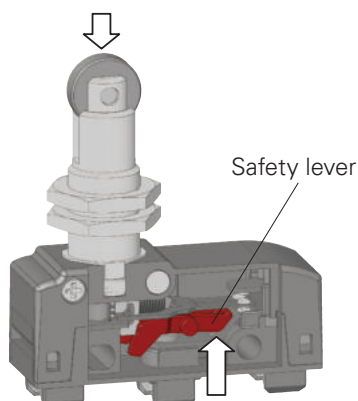

All microswitches showing the symbol  $\ominus$  besides the product code are with positive opening and therefore suitable for safety applications. These microswitches are provided with a rigid connection between the plunger and the NC contacts, which are forcibly actuated by an internal sturdy safety lever.

The positive opening has been designed in compliance with the standard EN 60947-5-1, Annex K. Therefore, these microswitches are suitable for safety applications.

### Protection degree IP65

By installing microswitches MK ●●2●●● with terminal covers VF MKC●22 or terminal covers VF MKC●23, a microswitch fully protected against water and dust is obtained. Thanks to their special oil resistant rubber gaskets the protection degree IP65 is provided. For applications in very dirty environments there are also versions with integrated double gasket for the plunger (internal + external). e.g. MK ●●2●12 or MK ●●2●13.

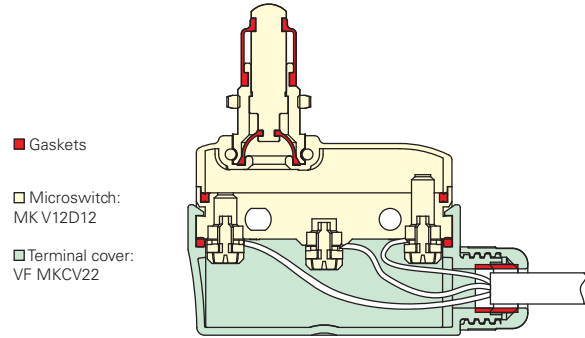

### Clamping screw plates for cables of different diameters (MK V●)

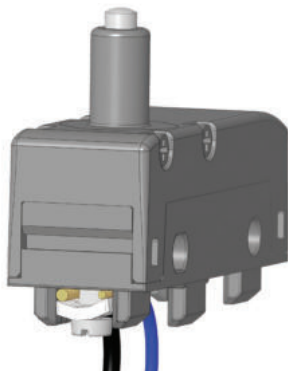

The clamping screw plates are provided with a particular “roofing tile” structure and are loosely coupled to the clamping screw. The design causes connection wires of different diameter to be pulled towards the screw when tightening the screw (see figure), preventing the wires from escaping towards the outside.

### Terminal covers with side-by-side strain relief cable gland

The terminal covers are provided with strain relief cable gland and protection degree up to IP65. These are snap-on terminal covers and have reduced dimensions contained in the profile of the microswitch so that these can be installed on microswitches fixed side by side as well.

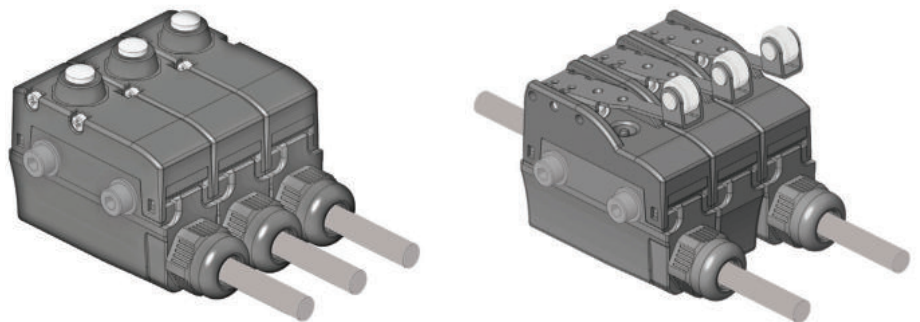

### Actuators with variable orientation

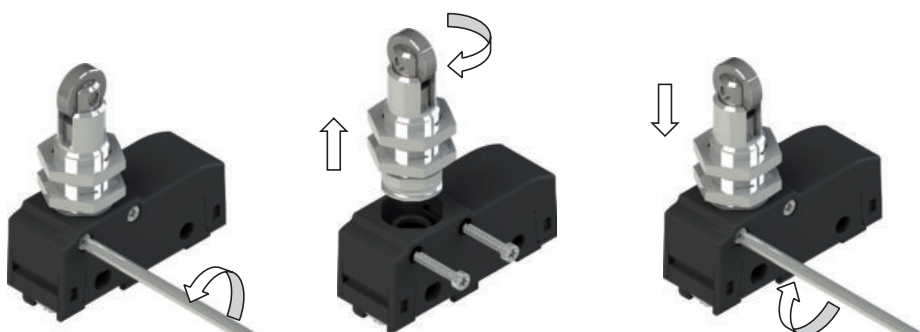

Thanks to the patented lateral fixing system, the roller of the microswitches MK ●●●15 and MK ●●17 can be now rotated in 90° steps.

The lateral fixing allows to disconnect the actuator from the switch body even when the actuator is already fixed to the support bracket. The flexibility of the product also allows for products to be unified in the warehouse for applications that require castors both in the longitudinal or transverse direction.

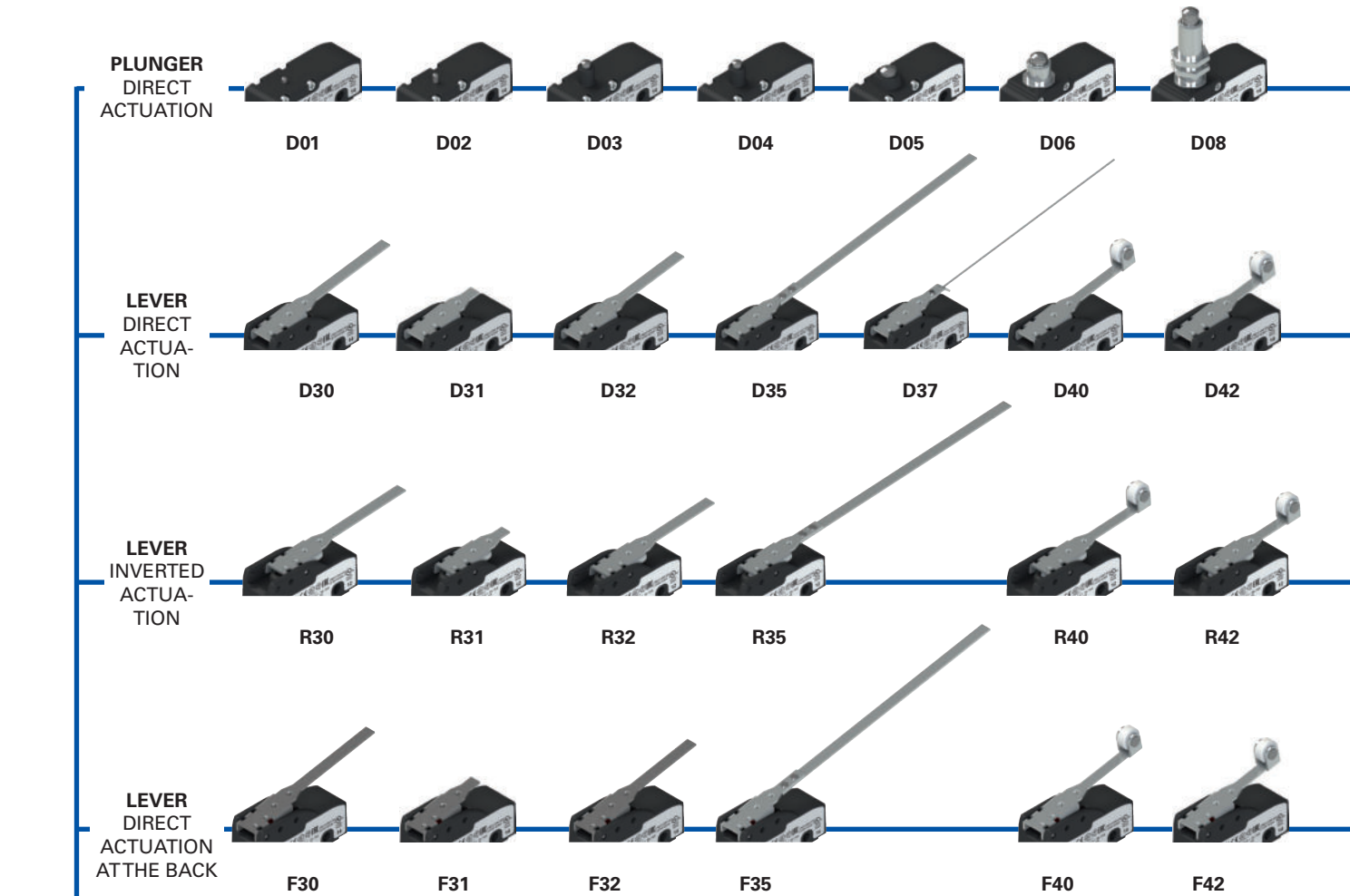

**ACTUATORS**

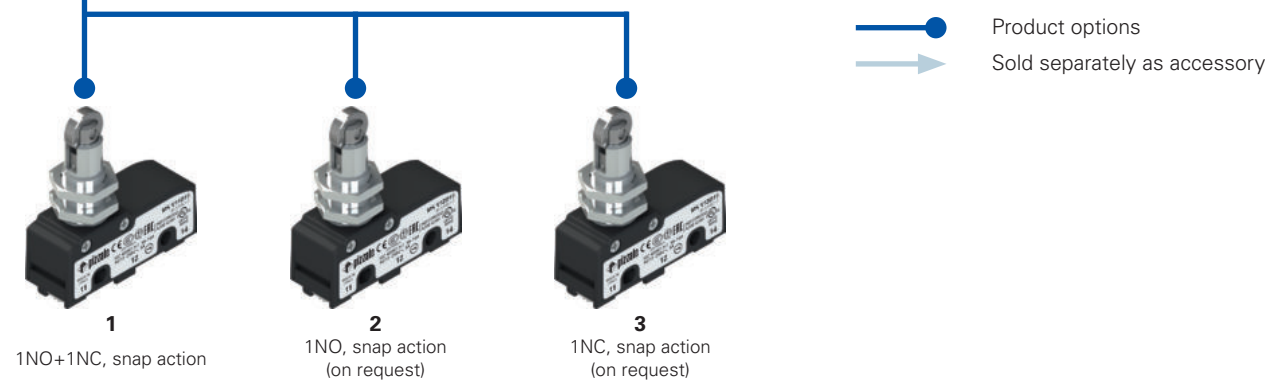

**TERMINALS**

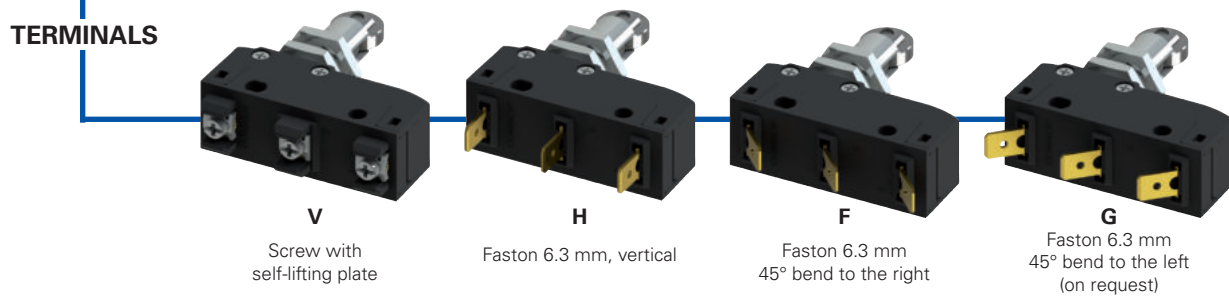

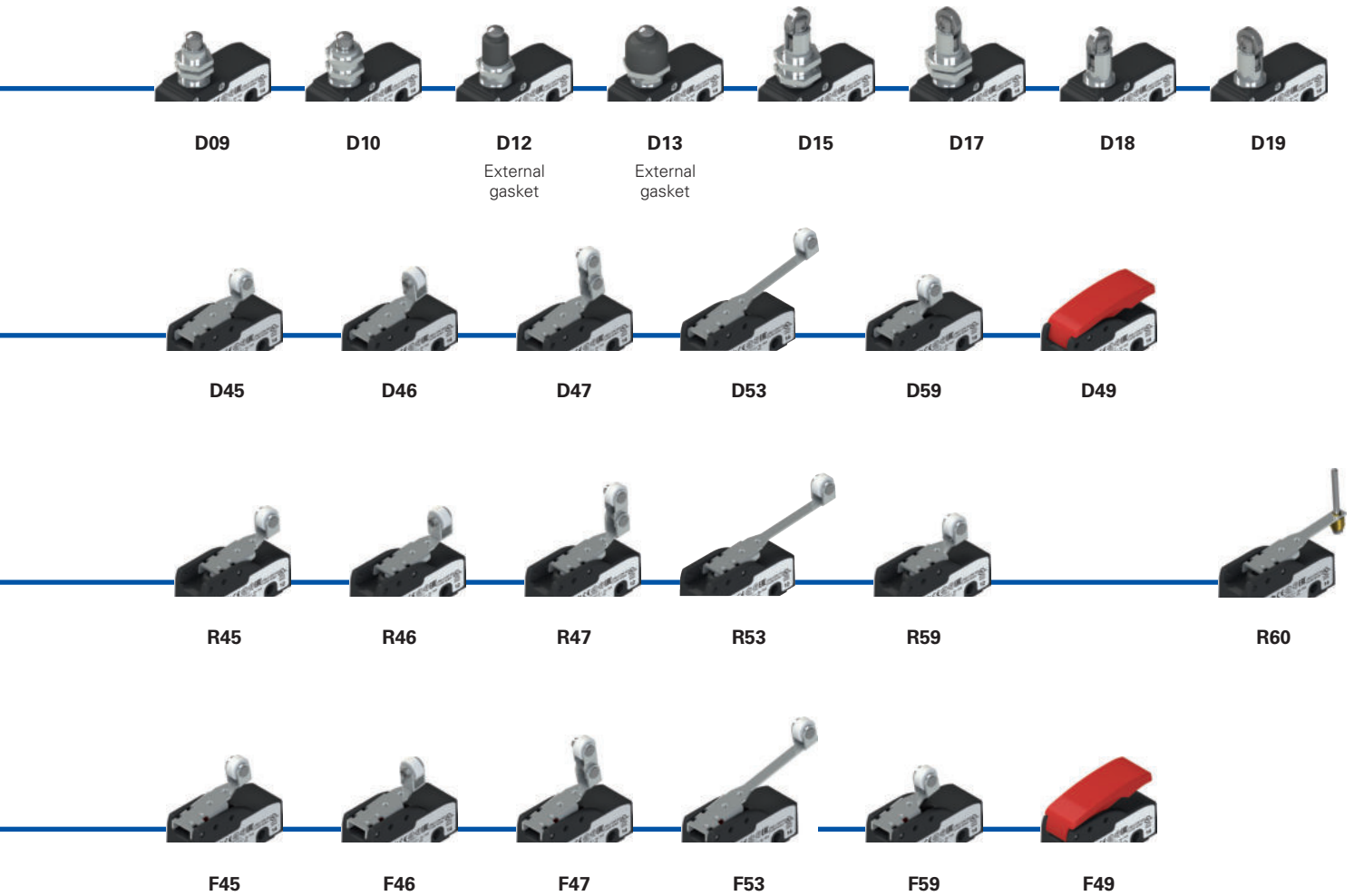
**Code structure**

**Attention!** The feasibility of a code number does not mean the effective availability of a product. Please contact our sales office.

article
options  
**MK V12D40-GR16T6**

Terminal type	
<b>V</b>	screw with self-lifting plate
<b>H</b>	vertical faston
<b>F</b>	Faston, 45° bend to the right
<b>G</b>	Faston, 45° bend to the left (on request)

Contact block	
<b>1</b>	1NO+1NC, snap action, change-over
<b>2</b>	1NO, snap action (on request)
<b>3</b>	1NC, snap action (on request)

Maximum protection degree	
<b>1</b>	IP40 (with terminal cover)
<b>2</b>	IP65 (with terminal cover)

Type of actuation	
<b>D</b>	direct actuation
<b>R</b>	inverted actuation
<b>F</b>	direct actuation at the back

Ambient temperature	
	-25°C ... +85°C (standard)
<b>T6</b>	-40°C ... +85°C

Rollers	
	standard roller
<b>R16</b>	metal roller Ø 9.5x4 mm (for actuators 40, 42, 45, 46, 47, 53, 59 only)
<b>R10</b>	large plastic roller Ø 9.8x8.4 mm (for actuators 40, 42, 45, 53 only)

Contact type	
	silver contacts (standard)
<b>G</b>	silver contacts, 1 µm gold coating

Actuator	
<b>01</b>	pin
<b>02</b>	pin
<b>03</b>	narrow plunger
...	...

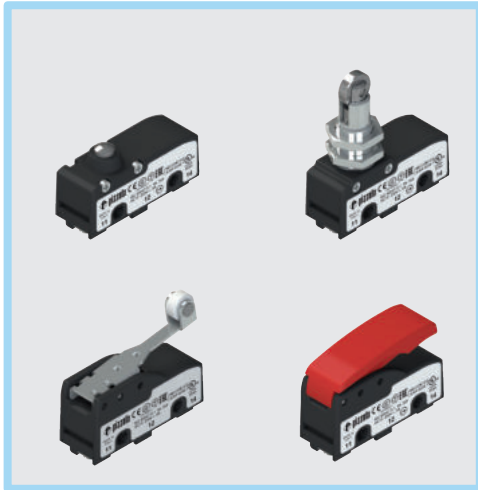

### Main features

- Technopolymer housing
- High reliability contacts
- Protection degree up to IP65
- 4 terminal types available
- 52 actuators available
- Versions with positive opening ⊕
- Versions with gold-plated silver contacts
- Terminal covers with strain relief cable gland

### Quality marks:



IMQ approval:	CA02.05772
UL approval:	E131787
CCC approval:	2021000305000105
EAC approval:	RU C-IT.YT03.B.00035/19

### Technical data

#### Housing

Housing made of glass fibre reinforced technopolymer, self-extinguishing and shock-proof.  
 Protection degree acc. to EN 60529: IP00 without terminal cover  
 IP20 (with terminal covers VF C01, VF C03)  
 IP40 (with terminal covers VF MKC•1•, VF C02)  
 IP65 (with terminal covers VF MKC•22 + MK V•2••• or VF MKC•23 + MK H•2•••)

#### General data

Ambient temperature: -25°C ... +85°C (standard)  
 -40°C ... +85°C (T6 option)  
 Max. actuation frequency: 3600 operating cycles/hour  
 Mechanical endurance: 10 million operating cycles  
 Safety parameter  $B_{10D}$ : 20,000,000 for NC contacts  
 Tightening torques for installation: see page 239

#### Conductor cross section (flexible copper strands)

MK series: min. 1 x 0.34 mm<sup>2</sup> (1 x AWG 22)  
 max. 2 x 1.5 mm<sup>2</sup> (2 x AWG 16)

#### Wire stripping length (x):

MK V••••• articles (screw connection): 7 mm

#### In compliance with standards:

IEC 60947-5-1, EN 60947-5-1, IEC 60529, EN 60529, EN 60947-1, IEC 60947-1, EN IEC 63000.

#### Approvals:

UL 508, CSA C22.2 No. 14, EN 60947-1, EN 60947-5-1.

#### Compliance with the requirements of:

Low Voltage Directive 2014/35/EU, EMC Directive 2014/30/EU, RoHS Directive 2011/65/EU.

#### Positive contact opening in conformity with standards:

IEC 60947-5-1, EN 60947-5-1.

### Installation for safety applications:

Use only microswitches marked with the ⊕ symbol beside the product code. Always connect the safety circuit to the **NC contacts** (normally closed contacts) as required by **EN ISO 14119, paragraph 5.4** for specific interlock applications and **EN ISO 13849-2 tables D3 (well-tried components) and D.8 (fault exclusions)** for safety applications in general. Actuate the switch **at least up to the positive opening travel (CAP)** reported next to the article code. Actuate the switch **at least with the positive opening force (FAP)** reported next to the article code.

**⚠ If not expressly indicated in this chapter, for correct installation and utilization of all articles see the instructions given on pages 227 to 242.**

#### Electrical data

Thermal current ( $I_{th}$ ):	16 A
Rated insulation voltage (U):	250 Vac 300 Vdc
Rated impulse withstand voltage ( $U_{imp}$ ):	4 kV
Conditional short circuit current:	1000 A acc. to EN 60947-5-1
Protection against short circuits:	type gG fuse 16 A 250 V
Pollution degree:	3
Dielectric strength	2000 Vac/min.

#### Utilization category

Alternating current: AC15 (50 ... 60 Hz)			
Ue (V)	120	250	
Ie (A)	3	5	
Direct current: DC13			
Ue (V)	24	125	250
Ie (A)	4	0.6	0.3



### Features approved by IMQ

Rated insulation voltage (U <sub>i</sub> ):	250 Vac
Conventional free air thermal current (I <sub>m</sub> ):	16 A
Protection against short circuits:	type gG fuse 16 A 250 V
Rated impulse withstand voltage (U <sub>imp</sub> ):	4 kV
Conditional short circuit current:	1000 A
Protection degree of the housing:	IP00
Terminals: screw terminals / faston	
Pollution degree:	3
Utilization category:	AC15
Operating voltage (U <sub>e</sub> ):	250 Vac (50 Hz)
Operating current (I <sub>e</sub> ):	5 A

Forms of the contact element: A, B, C.  
 Positive opening of contacts on contact blocks: 1, 3.  
 In compliance with standards: EN 60947-1, EN 60947-5-1, fundamental requirements of the Low Voltage Directive 2014/35/EU.

**Please contact our technical department for the list of approved products.**

### Features approved by UL

Electrical Ratings:	Q300 pilot duty (69 VA, 125-250 V dc) A300 pilot duty (720 VA, 120-300 V ac)
---------------------	---

**Please contact our technical department for the list of approved products.**

### Circuit diagram

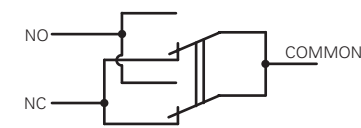

Mobile contact with single interruption and double contacts

With direct actuation and direct actuation at the back (F, D)

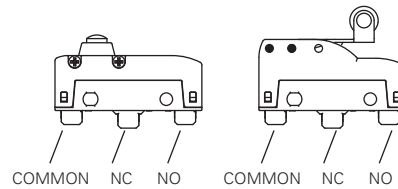

With inverted actuation (R)

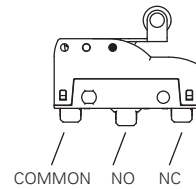

### Actuation forces and travels

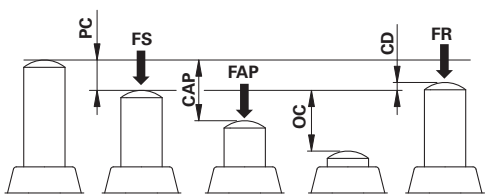

**PC** pre-travel  
**CAP** positive opening travel  
**OC** over-travel  
**CD** differential travel

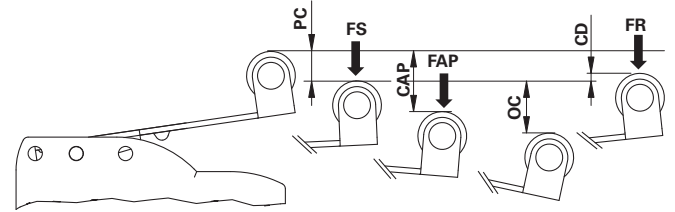

**FS** Trigger force  
**FR** release force  
**FAP** positive opening force

### Microswitches with direct actuation

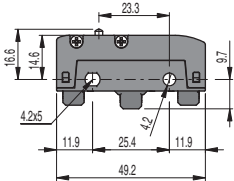
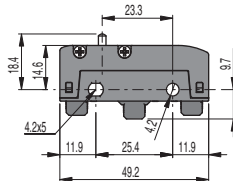
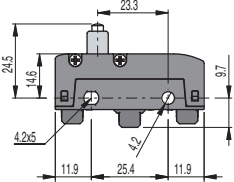
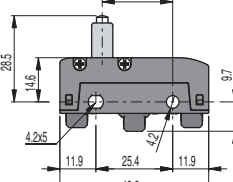
	
<b>MK V11D01</b> 1NO+1NC PC 0.5 mm OC 1.5 mm CD 0.05 mm FS 4 N FR 3 N	<b>MK V11D02</b> 1NO+1NC PC 0.5 mm OC 2 mm CD 0.05 mm FS 4 N FR 3 N
Maximum and minimum speed see page 239 - type 1	Maximum and minimum speed see page 239 - type 1
	
<b>MK V11D03</b> 1NO+1NC PC 0.5 mm OC 2 mm CD 0.05 mm FS 4 N FR 3 N	<b>MK V11D04</b> 1NO+1NC PC 0.5 mm OC 2 mm CD 0.05 mm FS 4 N FR 3 N
Maximum and minimum speed see page 239 - type 1	Maximum and minimum speed see page 239 - type 1

All values in the drawings are in mm

Accessories See page 207

→ The 2D and 3D files are available at [www.pizzato.com](http://www.pizzato.com)

<p><b>MK V11D05</b> (1NO+1NC) PC 0.5 mm FS 4 N OC 2 mm FR 3 N CD 0.05 mm FAP 20 N CAP 2.2 mm</p>	<p><b>MK V11D06</b> (1NO+1NC) PC 0.5 mm FS 4 N OC 3 mm FR 3 N CD 0.05 mm FAP 20 N CAP 2.2 mm</p>
<p>Maximum and minimum speed see page 239 - type 1</p>	
<p><b>MK V11D08</b> (1NO+1NC) PC 0.5 mm FS 4 N OC 5.5 mm FR 3 N CD 0.05 mm FAP 20 N CAP 2.2 mm</p>	<p><b>MK V11D09</b> (1NO+1NC) PC 0.5 mm FS 4 N OC 5.5 mm FR 3 N CD 0.05 mm FAP 20 N CAP 2.2 mm</p>
<p>Maximum and minimum speed see page 239 - type 1</p>	
<p><b>MK V11D10</b> (1NO+1NC) PC 0.5 mm FS 4 N OC 5.5 mm FR 3 N CD 0.05 mm FAP 20 N CAP 2.2 mm</p>	<p><b>MK V11D12</b> (1NO+1NC) PC 0.5 mm FS 4.5 N OC 5.5 mm FR 3 N CD 0.05 mm FAP 20 N CAP 2.2 mm</p>
<p>Maximum and minimum speed see page 239 - type 1</p>	
	<p>Mounting only through threaded fitting</p>
<p><b>MK V11D13</b> (1NO+1NC) PC 0.6 mm FS 6 N OC 5.4 mm FR 4 N CD 0.05 mm FAP 20 N CAP 2.2 mm</p>	<p><b>MK V11D15</b> (1NO+1NC) PC 0.5 mm FS 4 N OC 5.5 mm FR 3 N CD 0.05 mm FAP 20 N CAP 2.2 mm</p>
<p>Maximum and minimum speed see page 239 - type 1</p>	
<p>Mounting only through threaded fitting</p>	
<p><b>MK V11D17</b> (1NO+1NC) PC 0.5 mm FS 4 N OC 5.5 mm FR 3 N CD 0.05 mm FAP 20 N CAP 2.2 mm</p>	<p><b>MK V11D18</b> (1NO+1NC) PC 0.5 mm FS 4 N OC 5.5 mm FR 3 N CD 0.05 mm FAP 20 N CAP 2.2 mm</p>
<p>Maximum and minimum speed see page 239 - type 2</p>	

All values in the drawings are in mm

Accessories See page 207

The 2D and 3D files are available at [www.pizzato.com](http://www.pizzato.com)

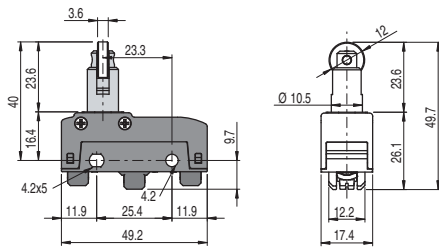

<b>MK V11D19</b>	1NO+1NC	PC	0.5 mm	FS	4 N
		OC	5.5 mm	FR	3 N
		CD	0.05 mm	FAP	20 N
		CAP	2.2 mm		

Maximum and minimum speed see page 239 - type 2

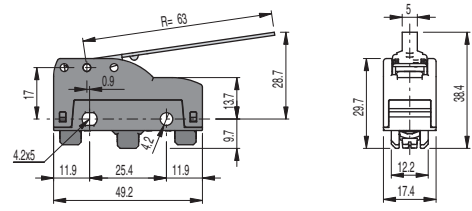

<b>MK V11D30</b>	1NO+1NC	PC	11.5 mm	FS	0.65 N
		OC	7.6 mm	FR	0.5 N
		CD	1.1 mm		

Maximum and minimum speed see page 239 - type 3

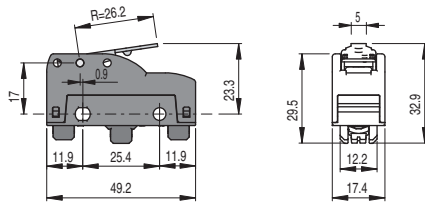

<b>MK V11D31</b>	1NO+1NC	PC	4.6 mm	FS	1.66 N
		OC	3.8 mm	FR	1.32 N
		CD	0.4 mm		

Maximum and minimum speed see page 239 - type 3

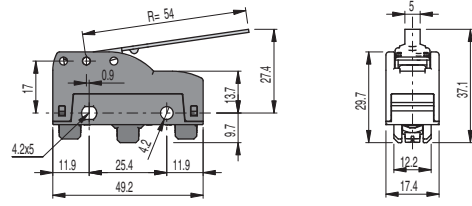

<b>MK V11D32</b>	1NO+1NC	PC	9.1 mm	FS	0.76 N
		OC	7.1 mm	FR	0.58 N
		CD	0.9 mm		

Maximum and minimum speed see page 239 - type 3

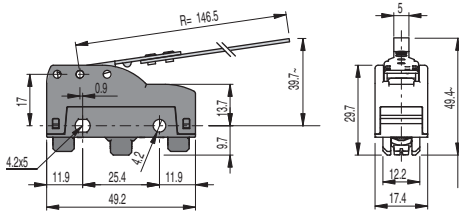

<b>MK V11D35</b>	1NO+1NC	PC	26.2 mm	FS	0.28 N
		OC	13.7 mm	FR	0.22 N
		CD	2.5 mm		

Maximum and minimum speed see page 239 - type 3

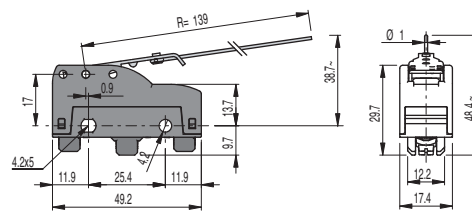

<b>MK V11D37</b>	1NO+1NC	PC	24.8 mm	FS	0.08 N
		OC	3.8 mm	FR	0.04 N
		CD	4.1 mm		

Maximum and minimum speed see page 239 - type 3

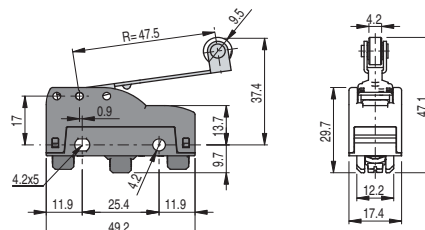

<b>MK V11D40</b>	1NO+1NC	PC	8.2 mm	FS	0.86 N
		OC	6.1 mm	FR	0.66 N
		CD	0.8 mm		

Maximum and minimum speed see page 239 - type 6

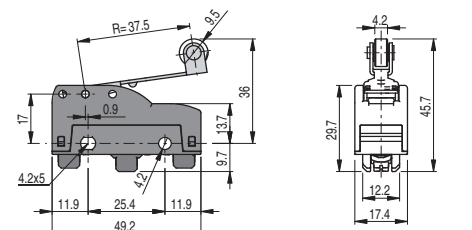

<b>MK V11D42</b>	1NO+1NC	PC	6.5 mm	FS	1.09 N
		OC	4.8 mm	FR	0.84 N
		CD	0.6 mm		

Maximum and minimum speed see page 239 - type 6

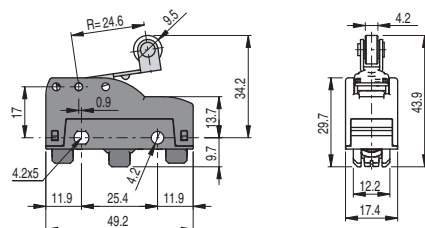

<b>MK V11D45</b>	1NO+1NC	PC	4.5 mm	FS	1.66 N
		OC	3.2 mm	FR	1.28 N
		CD	0.4 mm		

Maximum and minimum speed see page 239 - type 6

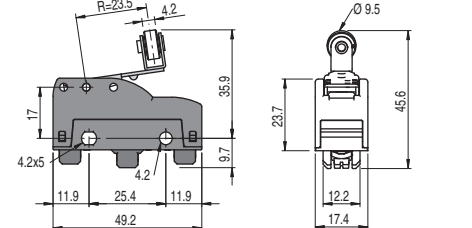

<b>MK V11D46</b>	1NO+1NC	PC	4.1 mm	FS	1.66 N
		OC	3.8 mm	FR	1.28 N
		CD	0.4 mm		

Maximum and minimum speed see page 239 - type 6

<b>MK V11D47</b> 1NO+1NC PC 4.2 mm FS 1.66 N OC 2.8 mm FR 1.28 N CD 0.4 mm	<b>MK V11D49</b> 1NO+1NC Hand operated
Maximum and minimum speed see page 239 - type 6	
<b>MK V11D53</b> 1NO+1NC PC 7.7 mm FS 0.76 N OC 7.8 mm FR 0.58 N CD 0.9 mm	<b>MK V11D59</b> 1NO+1NC PC 2.3 mm FS 2.3 N OC 4.5 mm FR 1.77 N CD 0.2 mm
Maximum and minimum speed see page 239 - type 6	
<b>Microswitches with inverted actuation</b>	
<b>MK V11R30</b> 1NO+1NC PC 5 mm FS 0.6 N OC 14 mm FR 0.4 N CD 0.7 mm	<b>MK V11R31</b> 1NO+1NC PC 1.9 mm FS 1.47 N OC 5.1 mm FR 0.72 N CD 0.23 mm
Maximum and minimum speed see page 239 - type 4	
<b>MK V11R32</b> 1NO+1NC PC 4.1 mm FS 0.7 N OC 11.2 mm FR 0.5 N CD 0.8 mm	<b>MK V11R35</b> 1NO+1NC PC 13.4 mm FS 0.3 N OC 24.3 mm FR 0.2 N CD 2.1 mm
Maximum and minimum speed see page 239 - type 4	
<b>MK V11R40</b> 1NO+1NC PC 2.8 mm FS 0.8 N OC 10.9 mm FR 0.5 N CD 0.45 mm	<b>MK V11R42</b> 1NO+1NC PC 2.7 mm FS 1.2 N OC 8.4 mm FR 1.7 N CD 0.5 mm
Maximum and minimum speed see page 239 - type 7	

All values in the drawings are in mm

Accessories See page 207

→ The 2D and 3D files are available at [www.pizzato.com](http://www.pizzato.com)

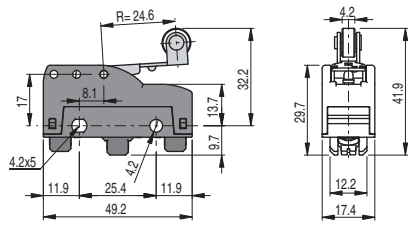

<b>MK V11R45</b>	1NO+1NC	PC	1.5 mm	FS	1.7 N
		OC	5.5 mm	FR	1 N
		CD	0.3 mm		

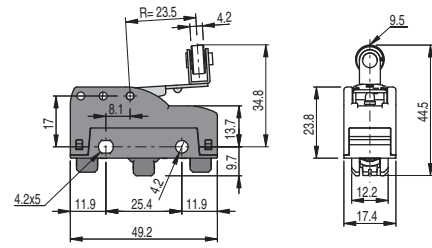

<b>MK V11R46</b>	1NO+1NC	PC	1.7 mm	FS	1.8 N
		OC	4.8 mm	FR	1.1 N
		CD	0.3 mm		

Maximum and minimum speed see page 239 - type 7

Maximum and minimum speed see page 239 - type 7

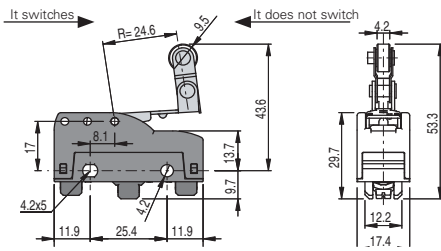

<b>MK V11R47</b>	1NO+1NC	PC	1.7 mm	FS	1.7 N
		OC	5.3 mm	FR	1 N
		CD	0.3 mm		

Maximum and minimum speed see page 239 - type 7

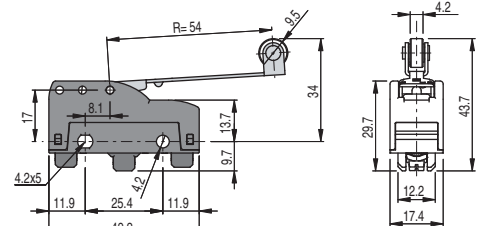

<b>MK V11R53</b>	1NO+1NC	PC	3.6 mm	FS	0.8 N
		OC	11.2 mm	FR	0.4 N
		CD	0.5 mm		

Maximum and minimum speed see page 239 - type 7

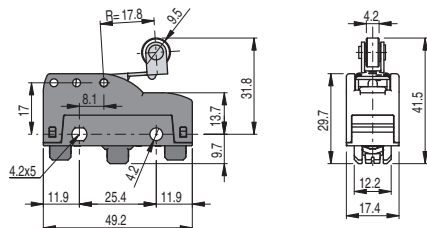

<b>MK V11R59</b>	1NO+1NC	PC	1.5 mm	FS	2.4 N
		OC	3.9 mm	FR	1.3 N
		CD	0.2 mm		

Maximum and minimum speed see page 239 - type 7

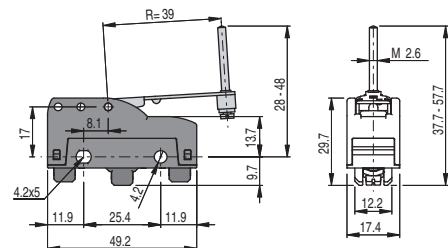

<b>MK V11R60</b>	1NO+1NC	PC	2.7 mm	FS	1.2 N
		OC	9.2 mm	FR	0.6 N
		CD	0.5 mm		

Maximum and minimum speed see page 239 - type 4

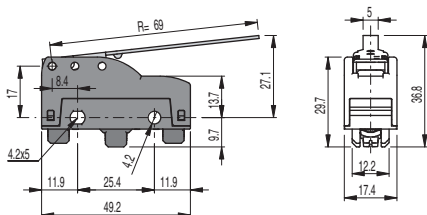
**Microswitches with direct actuation at the back**

<b>MK V11F30</b>	1NO+1NC	PC	3.2 mm	FS	0.6 N
		OC	11.2 mm	FR	0.5 N
		CD	0.35 mm		

Maximum and minimum speed see page 239 - type 5

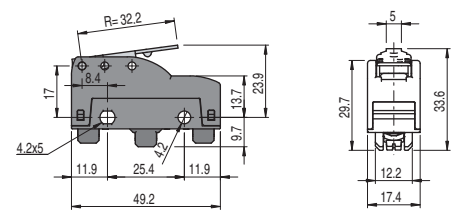

<b>MK V11F31</b>	1NO+1NC	PC	1.45 mm	FS	1.5 N
		OC	5 mm	FR	0.92 N
		CD	0.17 mm	FAP	5.78 N
		CAP	5.72 mm		

Maximum and minimum speed see page 239 - type 5

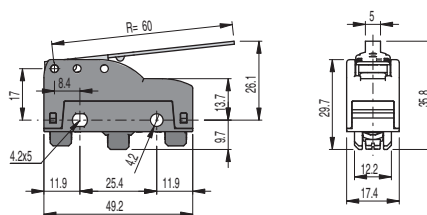

<b>MK V11F32</b>	1NO+1NC	PC	2.7 mm	FS	0.7 N
		OC	9.3 mm	FR	0.6 N
		CD	0.4 mm		

Maximum and minimum speed see page 239 - type 5

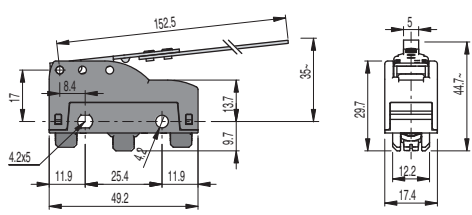

<b>MK V11F35</b>	1NO+1NC	PC	7.8 mm	FS	0.25 N
		OC	24.1 mm	FR	0.2 N
		CD	1.7 mm		

Maximum and minimum speed see page 239 - type 5

<b>MK V11F40</b>	1NO+1NC	PC	2.1 mm	FS	0.85 N
		OC	8.3 mm	FR	0.65 N
		CD	0.25 mm		

Maximum and minimum speed see page 239 - type 8

<b>MK V11F42</b>	1NO+1NC	PC	1.8 mm	FS	1 N
		OC	6.7 mm	FR	0.7 N
		CD	0.2 mm	FAP	4.9 N
		CAP	8 mm		

Maximum and minimum speed see page 239 - type 8

<b>MK V11F45</b>	1NO+1NC	PC	1.1 mm	FS	1.5 N
		OC	4.9 mm	FR	0.9 N
		CD	0.1 mm	FAP	6.9 N
		CAP	5.8 mm		

Maximum and minimum speed see page 239 - type 8

<b>MK V11F46</b>	1NO+1NC	PC	1.3 mm	FS	1.6 N
		OC	4.7 mm	FR	0.9 N
		CD	0.1 mm	FAP	6.9 N
		CAP	5.8 mm		

Maximum and minimum speed see page 239 - type 8

<b>MK V11F47</b>	1NO+1NC	PC	1.3 mm	FS	1.6 N
		OC	4.7 mm	FR	0.9 N
		CD	0.1 mm	FAP	6.9 N
		CAP	5.8 mm		

Maximum and minimum speed see page 239 - type 8

<b>MK V11F49</b>	1NO+1NC	PC	1.5 mm	FS	1 N
		OC	7.5 mm	FR	0.7 N
		CD	0.2 mm	FAP	4.8 N
		CAP	8 mm		

Maximum and minimum speed see page 239 - type 5

<b>MK V11F53</b>	1NO+1NC	PC	2.5 mm	FS	0.7 N
		OC	9.3 mm	FR	0.6 N
		CD	0.3 mm		

Maximum and minimum speed see page 239 - type 8

<b>MK V11F59</b>	1NO+1NC	PC	0.8 mm	FS	1.9 N
		OC	4.5 mm	FR	1.3 N
		CD	0.08 mm	FAP	8.9 N
		CAP	4.9 mm		

Maximum and minimum speed see page 239 - type 8

Terminal dimensions

All values in the drawings are in mm

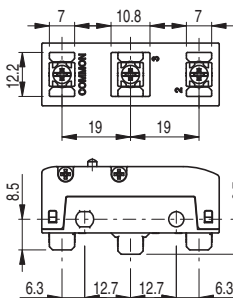

Screw terminals **V** with plate

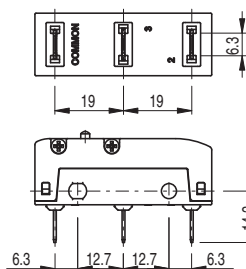

Faston terminals **H**, vertical

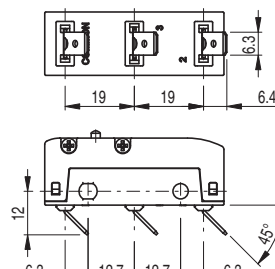

Faston terminals **F**, right angle

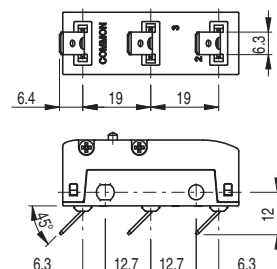

Faston terminals **G**, left angle (upon request)

**Note:** The vertical faston terminals H can be bent according to specific installation requirements. We recommend to bend the faston with an angle not higher than 45° and to carry out this operation no more than 5 times.

**Protective terminal covers**

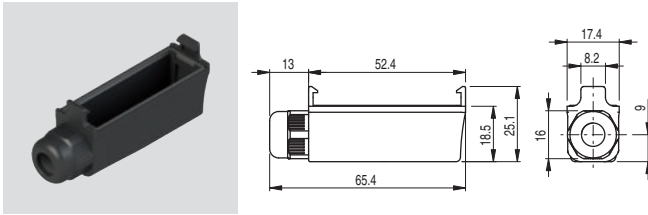
 Packs of **10 pcs.**

Protective terminal cover for screw terminals with strain relief cable gland and snap-in mounting. It allows to install multiple switches side-by-side.

Article	Description	Protection degree
VF MKCV11	Protective terminal cover without gasket for multipolar cables $\varnothing$ 5 ... 7.5 mm	IP40
VF MKCV12	Protective terminal cover without gasket for multipolar cables $\varnothing$ 4 ... 7.5 mm	IP40
VF MKCV13	Protective terminal cover without gasket for multipolar cables $\varnothing$ 2 ... 5.5 mm	IP40
VF MKCV22	Protective terminal cover with gasket for multipolar cables $\varnothing$ 4 ... 7.5 mm	IP65
VF MKCV23	Protective terminal cover with gasket for multipolar cables $\varnothing$ 2 ... 5.5 mm	IP65

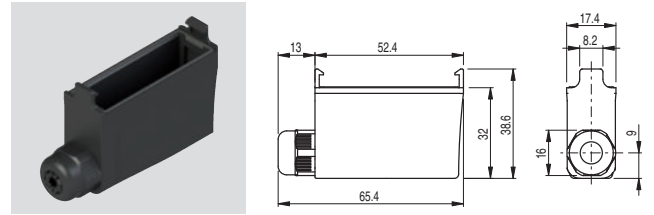

Protective terminal cover for vertical faston terminals with strain relief cable gland and snap-in mounting. It allows to install multiple switches side-by-side.

Article	Description	Protection degree
VF MKCH11	Protective terminal cover without gasket for multipolar cables $\varnothing$ 5 ... 7.5 mm	IP40
VF MKCH12	Protective terminal cover without gasket for multipolar cables $\varnothing$ 4 ... 7.5 mm	IP40
VF MKCH13	Protective terminal cover without gasket for multipolar cables $\varnothing$ 2 ... 5.5 mm	IP40
VF MKCH22	Protective terminal cover with gasket for multipolar cables $\varnothing$ 4 ... 7.5 mm	IP65
VF MKCH23	Protective terminal cover with gasket for multipolar cables $\varnothing$ 2 ... 5.5 mm	IP65

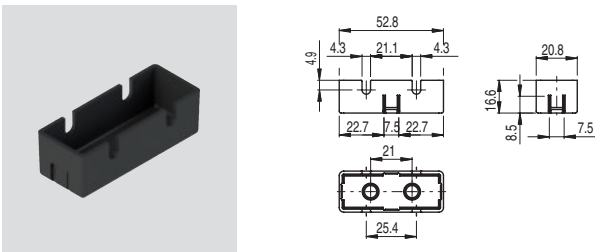

Article	Description	Protection degree
VF C01	Protective terminal cover for screw terminals	IP20

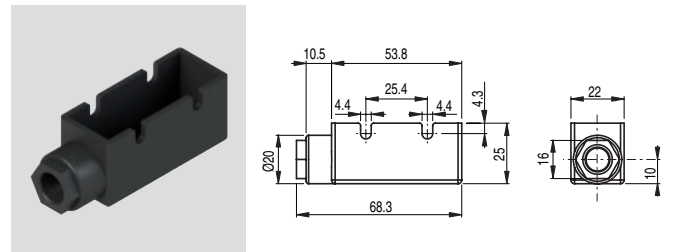

Article	Description	Protection degree
VF C02	Protective terminal cover for screw terminals with PG9 cable gland for multipolar cables $\varnothing$ 5 ... 7 mm	IP40

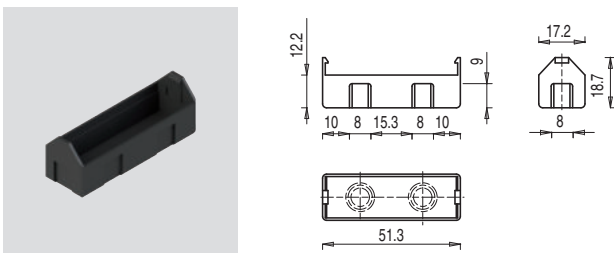

Article	Description	Protection degree
VF C03	Protective terminal cover for screw terminals, snap-in mounting. It allows to install multiple switches side-by-side	IP20

**Accessories**

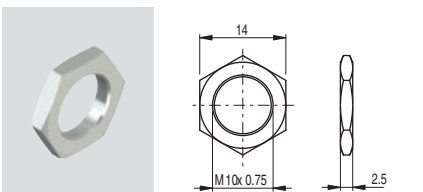
 Packs of **10 pcs.**

Article	Description
VF AC83	Hex threaded nut for microswitches with actuators D06, D08, D09

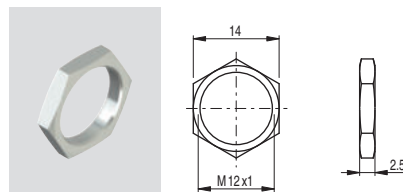

Article	Description
VF AC72	Hex threaded nut for microswitches with actuators D10, D12, D13

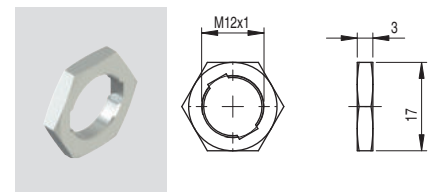

Article	Description
AC 35	Hex threaded nut, notched, for microswitches with actuators D15, D17

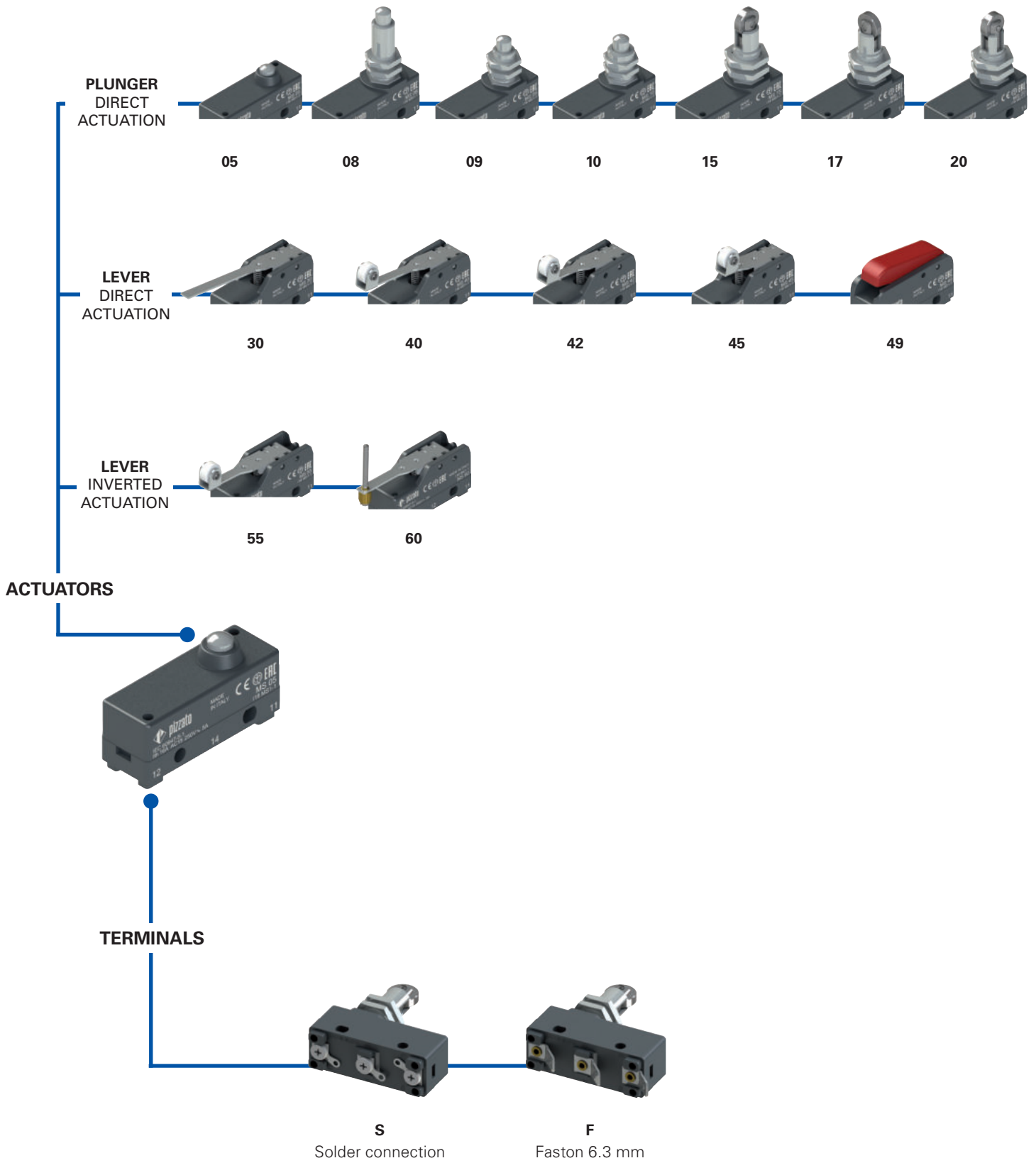

- Product options
- ▶— Sold separately as accessory

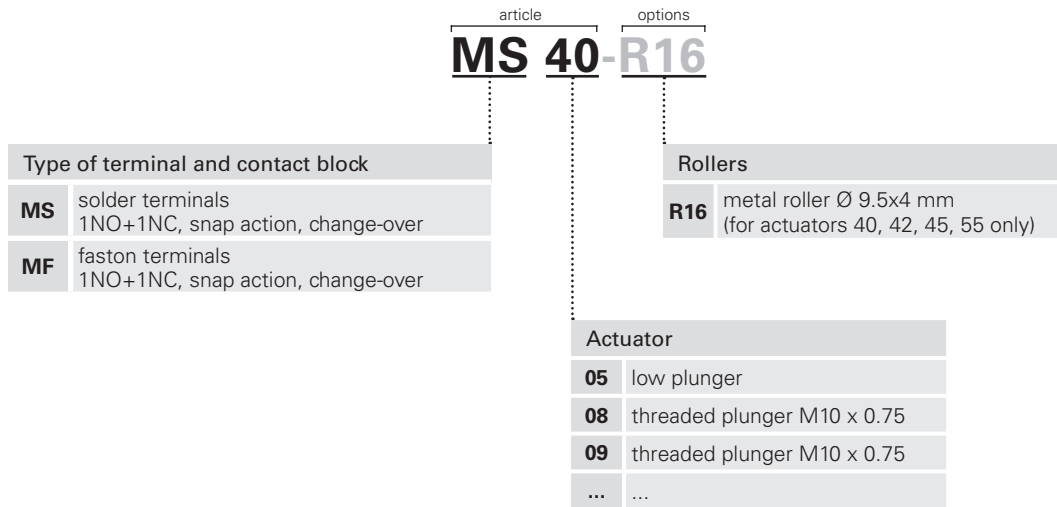

**Code structure****Attention!** The feasibility of a code number does not mean the effective availability of a product. Please contact our sales office.

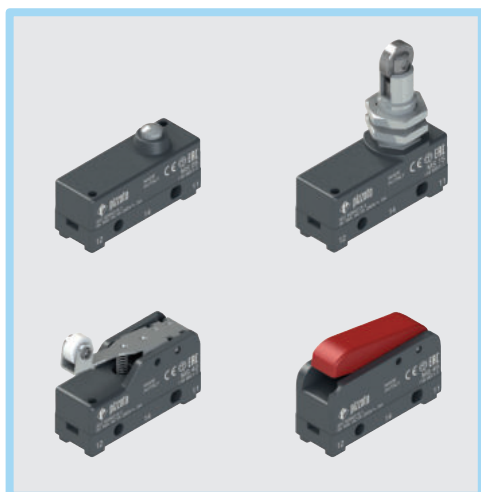

### Main features

- Technopolymer housing
- Protection degree IP20 or IP40
- 2 terminal types available
- 13 actuators available

### Quality marks:



IMQ approval: CA02.05772  
EAC approval: RU C-IT.YT03.B.00035/19

### Technical data

#### Housing

Housing made of glass fibre reinforced technopolymer, self-extinguishing and shock-proof.

Protection degree acc. to EN 60529: IP00 (without terminal cover)  
IP20 (with terminal covers VF C01, VF C03)  
IP40 (with terminal cover VF C02)

#### General data

Ambient temperature: -25°C ... +85°C  
Max. operating frequency: 3600 operating cycles/hour  
Mechanical endurance: 10 million operating cycles  
Tightening torques for installation: see page 240

#### In compliance with standards:

IEC 60947-5-1, EN 60947-5-1, IEC 60528, EN 60529, EN IEC 63000

#### Approvals:

EN 60947-5-1

#### Compliance with the requirements of:

Low Voltage Directive 2014/35/EU,  
EMC Directive 2014/30/EU,  
RoHS Directive 2011/65/EU.

**⚠ If not expressly indicated in this chapter, for correct installation and utilization of all articles see the instructions given on pages 227 to 242.**

### Electrical data

Thermal current ( $I_{th}$ ): 16 A  
Rated insulation voltage ( $U_i$ ): 250 Vac 300 Vdc  
Rated impulse withstand voltage ( $U_{imp}$ ): 4 kV  
Conditional short circuit current: 1000 A acc. to EN 60947-5-1  
Protection against short circuits: type gG fuse 16 A 250 V  
Pollution degree: 3  
Dielectric strength: 2000 V~ (between terminals and other metal parts to ground)

### Utilization category

Alternating current: AC15 (50÷60 Hz)  
 $U_e$  (V) 250  
 $I_e$  (A) 5  
Direct current: DC13  
 $U_e$  (V) 24 125 250  
 $I_e$  (A) 5 0.5 0.3

### Features approved by IMQ

Rated insulation voltage ( $U_i$ ): 250 Vac  
Conventional free air thermal current ( $I_{th}$ ): 16 A  
Protection against short circuits: type gG fuse 16 A 250 V  
Rated impulse withstand voltage ( $U_{imp}$ ): 4 kV  
Conditional short circuit current: 1000 A  
MF, MS terminals  
Pollution degree: 3  
Utilization category: AC15  
Operating voltage ( $U_e$ ): 250 Vac (50 Hz)  
Operating current ( $I_e$ ): 5 A

Forms of the contact element: C

In compliance with standards: EN 60947-1, EN 60947-5-1, fundamental requirements of the Low Voltage Directive 2014/35/EU.

**Please contact our technical department for the list of approved products.**

### Orientable roller

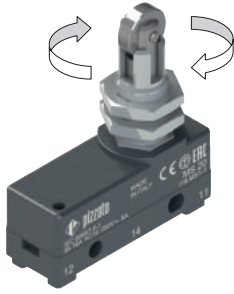

It is possible to rotate the roller of the M•20 microswitch in 90° steps.

### Circuit diagram

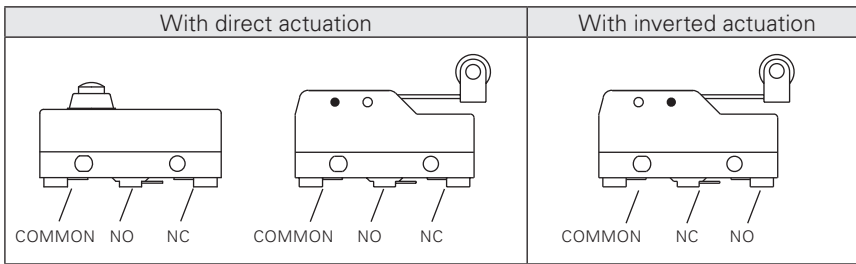

Change-over contact element with single interruption and three terminals.

### Actuation forces and travels

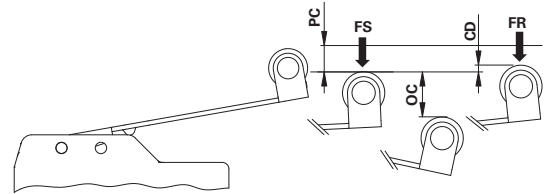
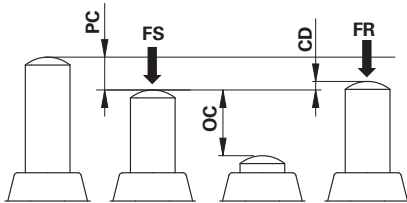

- PC** pre-travel
- OC** over-travel
- FR** release force
- CD** differential travel
- FS** Trigger force

### Microswitches with direct actuation

All values in the drawings are in mm

	<b>MS 05</b> PC 0.5 mm OC 2 mm CD 0.05 mm FS 3.9 N FR 2.7 N		<b>MS 08</b> PC 0.5 mm OC 5.5 mm CD 0.05 mm FS 3.9 N FR 2.7 N
Maximum and minimum speed see page 240 - type 1		Maximum and minimum speed see page 240 - type 1	
	<b>MS 09</b> PC 0.5 mm OC 5.5 mm CD 0.05 mm FS 3.9 N FR 2.7 N		<b>MS 10</b> PC 0.5 mm OC 5.5 mm CD 0.05 mm FS 3.9 N FR 2.7 N
Maximum and minimum speed see page 240 - type 1		Maximum and minimum speed see page 240 - type 1	

## MS - MF series microswitches

Secured only by means of threaded head		Secured only by means of threaded head	
<b>MS 15</b>	PC 0.5 mm OC 5.5 mm CD 0.05 mm	FS 3.9 N FR 2.7 N	
Maximum and minimum speed see page 240 - type 2		Maximum and minimum speed see page 240 - type 2	
Secured only by means of threaded head			
<b>MS 20</b>	PC 0.5 mm OC 5.5 mm CD 0.05 mm	FS 3.9 N FR 2.7 N	<b>MS 30</b>
Maximum and minimum speed see page 240 - type 2		Maximum and minimum speed see page 240 - type 3	
Secured only by means of threaded head			
<b>MS 40</b>	PC 8.9 mm OC 4.3 mm CD 0.6 mm	FS 0.7 N FR 0.6 N	<b>MS 42</b>
Maximum and minimum speed see page 240 - type 6		Maximum and minimum speed see page 240 - type 6	
Secured only by means of threaded head			
<b>MS 45</b>	PC 4.9 mm OC 3.2 mm CD 0.2 mm	FS 1.5 N FR 1.2 N	<b>MS 49</b>
Maximum and minimum speed see page 240 - type 6		Maximum and minimum speed see page 240 - type 1	
<b>Microswitches with inverted actuation</b>			
All values in the drawings are in mm			
Secured only by means of threaded head			
<b>MS 55</b>	1NO+1NC PC 2 mm OC 7.7 mm CD 0.3 mm	FS 1.1 N FR 0.8 N	<b>MS 60</b>
Maximum and minimum speed see page 240 - type 7		Maximum and minimum speed see page 240 - type 7	

To order a product with faston terminals

replace MS with MF in the article codes. Example: MS15 → MF15

**Terminal dimensions**

All values in the drawings are in mm

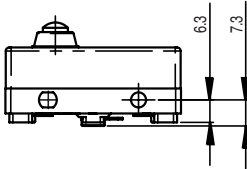
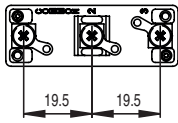
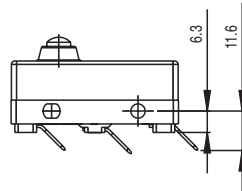
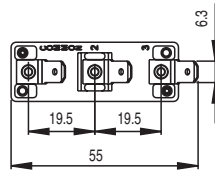
**Solder terminals**

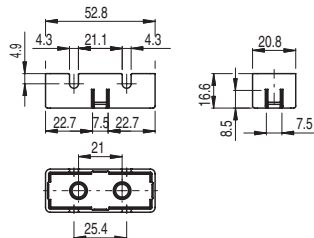
**Faston terminals**

**Protective terminal covers**

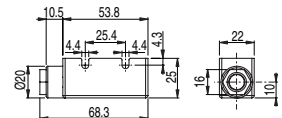
 Packs of **10 pcs.**

Article	Description	Protection degree
VF C01	Protective terminal cover for screw terminals	IP20

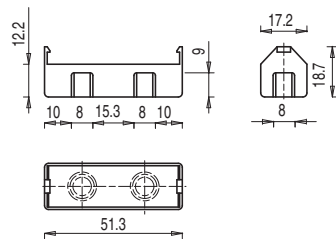

Article	Description	Protection degree
VF C02	Protective terminal cover for screw terminals with PG9 cable gland for multipolar cables Ø 5 ... 7 mm	IP40



Article	Description	Protection degree
VF C03	Protective terminal cover for screw terminals, snap-in mounting. It allows to install multiple switches side-by-side	IP20

**Accessories**

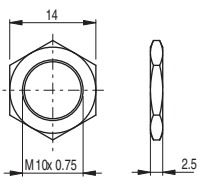
 Packs of **10 pcs.**

Article	Description
VF AC83	Hex threaded nut for microswitches with actuators D06, D08, D09

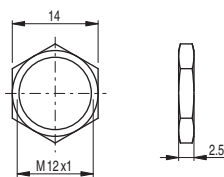

Article	Description
VF AC72	Hex threaded nut for microswitches with actuators D10, D12, D13

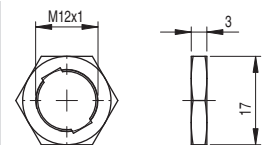

Article	Description
AC 35	Hex threaded nut, notched, for microswitches with actuators D15, D17



# ATEX



**Technical definitions**
**page 159**

**FD series position switches**
**page 161**

Category	Zone	EPL	Approvals	Product code extension	ATEX/EPL category				
					M2/Mb	2G/Gb	2D/Db	3G/Gc	3D/Dc
3D	22	Dc	II 3D Ex tc IIIC T80°C Dc	-EX4	-	-	-	-	■
2G M2	1 M2	Gb Mb	II 2G Ex ia IIC T6 Gb I M2 Ex ia I Mb	-EX7	■	■	-	■	-
2D	21	Db	II 2D Ex tb IIIC T80°C Db	-EX8	-	-	■	-	■

**FL series position switches**
**page 167**

Category	Zone	EPL	Approvals	Product code extension	ATEX/EPL category				
					M2/Mb	2G/Gb	2D/Db	3G/Gc	3D/Dc
3D	22	Dc	II 3D Ex tc IIIC T80°C Dc	-EX4	-	-	-	-	■
2G M2	1 M2	Gb Mb	II 2G Ex ia IIC T6 Gb I M2 Ex ia I Mb	-EX7	■	■	-	■	-
2D	21	Db	II 2D Ex tb IIIC T80°C Db	-EX8	-	-	■	-	■

**FM series position switches**
**page 173**

Category	Zone	EPL	Approvals	Product code extension	ATEX/EPL category				
					M2/Mb	2G/Gb	2D/Db	3G/Gc	3D/Dc
2G M2	1 M2	Gb Mb	II 2G Ex ia IIC T6 Gb I M2 Ex ia I Mb	-EX7	■	■	-	■	-

**FA series pre-wired position switches**
**page 179**

Category	Zone	EPL	Approvals	Product code extension	ATEX/EPL category				
					M2/Mb	2G/Gb	2D/Db	3G/Gc	3D/Dc
3D 3G	22 2	Dc Gc	II 3D Ex tc IIIC T80°C Dc II 3G Ex nC IIC T6 Gc	-EX5	-	-	-	■	■

**Accessories**
**page 183**

## ATEX Directive

The acronym ATEX ( **A**tmospheres **E**xplosives) refers to two European directives concerning the risk of deflagration in potentially explosive atmospheres:

- ATEX 2014/34/EU: concerns the requirements for electrical and non-electrical equipment for use in potentially explosive environments. According to this directive, the manufacturer has to comply with the provided requirements and mark its articles according to specific categories.
- ATEX 99/92/EC: lays down minimum requirements for the safety and health protection of workers potentially at risk from explosive atmospheres.

These directives define the requirements for the protection of safety and health of persons, domestic animals and property, as well as the conformity assessment procedures to prove that the devices comply with the directives' requirements.

## Classification of potentially explosive atmospheres

A potentially explosive atmosphere is an atmosphere which could become explosive due to local and/or operational conditions. These environments present a mixture with air under atmospheric conditions of flammable substances in the form of in the form of gases, vapours, mists or dusts.

The ATEX 99/92/EC Directive classifies two types of potentially explosive atmospheres, depending on presence of combustible gases or dusts in the zone. These two types of explosive atmospheres are in turn classified in three zones each, according to the frequency and duration of the explosive atmosphere. Areas in atmospheres with explosive gases are classified in zones 0, 1 and 2; whereas in atmospheres with explosive dusts in zones 20, 21 and 22:

- Zone 0/20: A place in which the presence of flammable gas or dust is continuously present. Constant danger. It requires at least Category 1 equipment.
- Zone 1/21: A place in which the presence of flammable gas or dust is likely to occur in normal operation occasionally. Potential danger. It requires at least Category 2 equipment.
- Zone 2/22: A place in which the presence of flammable gas or dust is not likely to occur in normal operation or, if it does occur, will persist for a short period only. Or it occurs due to a failure. Lower danger. It requires at least Category 3 equipment.

The end user has the responsibility to identify and classify the different zones and to install appropriate equipment.

## Equipment categories acc. to ATEX directive and IEC standards

According to the ATEX Directive 2014/34/EU equipment is classified into two main groups:

- Group I: equipment and systems for mining
- Group II: equipment and systems for all other applications

Equipment of the group I is divided in two further categories according to the required protection level:

- Category M1: Equipment designed to ensure a very high level of protection
- Category M2: Equipment designed to ensure a high level of protection

Equipment of the group II is further subdivided into three categories according to the required protection level:

- Category 1: Equipment designed to ensure a very high level of protection (for use in zone 0 and 20, 1 and 21, 2 and 22)
- Category 2: Equipment designed to ensure a high level of protection (for use in zone 1 and 21, 2 and 22)
- Category 3: Equipment designed to ensure a normal level of protection (for use in zone 2 and 22)

A comparison between the EPL (Equipment Protection Levels) defined by the IEC 60079-0 standard and the categories and applications of the ATEX Directive are shown in table 1.

Environment features				Equipment features				
Field of application	Flammable substance	Potentially explosive atmosphere	Classification of potentially explosive atmospheres: ZONE	acc. to ATEX 2014/34/EU		acc. to IEC 60079-0		Required protection level
				Required marking of the device: CATEGORY	Required marking of the device: GROUP	Group	EPL	
Mining				M1	I	I	Ma	very high
				M2			Mb	high
Surface	Gases	It is present continuously, or for long periods or frequently	0	1G	II	II	Ga	very high
		It is likely to occur	1	2G			Gb	high
		It is not likely to occur but, if it does occur, will persist for a short period only	2	3G			Gc	normal
	Dusts	It is present continuously, or for long periods or frequently	20	1D		III	Da	very high
		It is likely to occur	21	2D			Db	high
		It is not likely to occur but, if it does occur, will persist for a short period only	22	3D			Dc	normal

Table 1 – Classification of environment and equipment according to ATEX directive and IEC 60079-0 standard



## Protective measures

To avoid the risk of explosions caused by an electrical trigger in a potentially explosive atmosphere, different protective measures can be taken:

- use of enclosures to encapsulate dangerous part in order to limit explosions to the inside of the housing itself;
- avoid contact between hot spots and the potentially explosive atmosphere by interposing solid, liquid or gaseous bodies;
- take measures to limit the generation of dangerous hot spots, eliminating the possibility of failures or limiting the system power so that it is insufficient to cause the ignition.

Various protective modes have been developed and standardised for each of these modes as listed in table 2.

Protective measure	Symbol	Engraving	Zone GAS	Zone DUSTS	IEC / EN standard
<b>General requirements</b>	/	/	0, 1, 2	20, 21, 22	IEC 60079-0 EN 60079-0
<b>Oil immersion</b>		Ex ob Ex oc	1 2	/	IEC 60079-6 EN 60079-6
<b>Pressurized enclosure</b>		Ex pv Ex pxb Ex pyb Ex pzc	1, 2 1 1 2	/ 21 21 22	IEC 60079-2 EN 60079-2
<b>Powder filling</b>		Ex q	1	/	IEC 60079-5 EN 60079-5
<b>Flameproof enclosure</b>		Ex da Ex db Ex dc	0 1 2	/	IEC 60079-1 EN 60079-1
<b>Increased safety</b>		Ex eb Ex ec	1 2	/	IEC 60079-7 EN 60079-7
<b>Intrinsic safety</b>		Ex ia Ex ib Ex ic	0 1 2	20 21 22	IEC 60079-11 EN 60079-11
<b>Encapsulation</b>		Ex ma Ex mb Ex mc	0 1 2	20 21 22	IEC 60079-18 EN 60079-18
<b>Non sparking</b>		Ex nA Ex nC Ex nR	2 2 2	/	IEC 60079-15 EN 60079-15
<b>Protective housing</b>		Ex ta Ex tb Ex tc	/	20 21 22	IEC 60079-31 EN 60079-31
<b>Optical radiation</b>		Ex op is Ex op pr Ex op sh	0, 1, 2 1, 2 0, 1, 2	20, 21, 22 21, 22 20, 21, 22	IEC 60079-28 EN 60079-28

**Table 2 - Protective measures and applicable standards**

## Marking examples

### Devices for places with presence of gas

**Ex II 2G Ex ia IIC T6 Gb**

① ② ③ ④ ⑤ ⑥ ⑦ ⑧

- ① EU marking
- ② Equipment group (see table 1)
- ③ Protection category (see table 1)
- ④ Prefix for safety devices according to the IEC / EN standards
- ⑤ Type of protection (see table 2)
- ⑥ Classification of gases (see table 4)
- ⑦ Temperature class (see table 3)
- ⑧ EPL acc. to IEC 60079-0 (see table 1)

### Devices for places with presence of dusts

**Ex II 3D Ex tc IIIC T80°C Dc**

① ② ③ ④ ⑤ ⑥ ⑦ ⑧

- ① EU marking
- ② Equipment group (see table 1)
- ③ Protection category (see table 1)
- ④ Prefix for safety devices according to the IEC / EN standards
- ⑤ Type of protection (see table 2)
- ⑥ Classification of dusts (see table 5)
- ⑦ Maximum surface temperature of the equipment
- ⑧ EPL acc. to IEC 60079-0 (see table 1)

Class	T1	T2	T3	T4	T5	T6
Maximum surface temperature of the equipment	450 °C	300 °C	200 °C	135 °C	100 °C	85 °C

**Table 3 - Temperature classes**

	I	IIA	IIB	IIC
<b>T1</b>	methane	propane, industrial methane, ethane, benzene, ammoniac, acetic acid, carbon monoxide, methanol, toluene	acrylonitrile	hydrogen
<b>T2</b>		ethanol, amyl acetate, butane	ethylene	acetylene
<b>T3</b>		nafta, benzene, esano	hydrogen sulfide	
<b>T4</b>		acetaldehyde	ethyl ether	
<b>T5</b>				
<b>T6</b>				carbon disulfide

**Table 4 - Classification of gases (excerpt from standard IEC/CENELEC/NEC 505)**

IIIA	IIB	IIC
combustible particles	non-conductive powder	conductive powder



**Table 5 - Classification of dusts**



### Main features

- ATEX approval
- Metal housing, one conduit entry
- Protection degree IP66
- Versions with gold-plated silver contacts

### ATEX markings:

Product code extension	Quality mark	Certificate type and notified body
<b>-EX4</b>		EU declaration of conformity Pizzato Elettrica S.r.l.
<b>-EX7</b>		EU type examination certificate TÜV Italia
<b>-EX8</b>		EU type examination certificate TÜV Italia

### Installation for safety applications:

Use only switches marked with the  symbol beside the product code. Always connect the safety circuit to the **NC contacts** (normally closed contacts: 11-12, 21-22 or 31-32) as required by **EN ISO 14119, paragraph 5.4** for specific interlock applications and **EN ISO 13849-2 tables D3** (well-tried components) and **D.8** (fault exclusions) for safety applications in general. Actuate the switch **at least up to the positive opening travel** shown in the travel diagrams on page 230. Actuate the switch **at least with the positive opening force**, reported in brackets below each article, next to the actuating force value.

**⚠ If not expressly indicated in this chapter, for correct installation and utilization of all articles see the instructions given in the registration certificate, in the operating manual and on pages 227 to 242.**

**⚠ For the correct use of the switch, please use appropriate cable glands suitable for the zone in compliance with the ATEX directive, see Accessories on page 183.**

### Technical data

#### Housing

Metal housing, powder-coated	
One threaded conduit entry:	M20x1.5
Protection degree acc. to EN 60529:	IP66 with cable gland of equal or higher protection degree

#### General data

Ambient temperature (-EX7):	-20°C ... +60°C
Ambient temperature (-EX4/-EX8):	-20°C ... +70°C
Max. actuation frequency:	3600 operating cycles/hour
Mechanical endurance:	
FD ●●●●-EX●	10 million operating cycles
FD ●●93-EX●, FD ●●78-EX●, FD ●●8●-EX●, FD ●●95-EX●	500,000 operating cycles
FD ●●99-EX●, FD ●●R2-EX●	250,000 operating cycles
Mounting position:	any
Safety parameters B <sub>10D</sub> (NC contacts):	
FD ●●●●-EX●	20,000,000
FD ●●93-EX●, FD ●●78-EX●, FD ●●8●-EX●	1,000,000
FD ●●99-EX●, FD ●●R2-EX●	500,000
FD ●●95-EX●	2,500,00
Mechanical interlock, not coded:	type 1 acc. to EN ISO 14119
Tightening torques for installation:	see page 229
Wire cross-sections and wire stripping lengths:	see page 249

#### Contact blocks available:

2, 3, 5, 6, 7, 8, 9, 10, 11, 12, 13, 14, 15, 16, 18, 20, 21, 22, 28, 29, 30, 33, 34, 37, 66, 67

**Note:** contact blocks 2 and 3 are not available for articles FD ●●●●-EX7, FD ●●●●-EX8.

#### In compliance with standards:





IEC 60947-5-1, EN 60947-5-1, EN 60947-1, EN 50041, IEC 60204-1, EN 60204-1, EN ISO 14119, EN ISO 12100, IEC 60529, EN 60529, UL 508, CSA C22.2 No. 14, IEC 60079-0, EN 60079-0, IEC 60079-11, EN 60079-11, EN IEC 63000.

#### Compliance with the requirements of:

ATEX Directive 2014/34/EU, EMC Directive 2014/30/EU, RoHS Directive 2011/65/EU.

#### Positive contact opening in conformity with standards:

IEC 60947-5-1, EN 60947-5-1.

Product code extension	Category	Zone	EPL	Approvals	Electrical data	Utilization category
<b>-EX4</b>	3D	22	Dc	 II 3D Ex tc IIIC T80°C Dc	Thermal current (I <sub>th</sub> ): 10 A Rated insulation voltage (U <sub>i</sub> ): 500 Vac 600 Vdc 400 Vac for contact blocks 20, 28 Conditional short circuit current: 1000 A acc. to EN 60947-5-1 Protection against short circuits: type aM fuse 10 A 500 V Pollution degree: 3	Alternating current: AC15 (50÷60 Hz) Ue (V) 250 400 500 Ie (A) 6 4 1 Direct current: DC13 Ue (V) 24 125 250 Ie (A) 3 0.55 0.3
<b>-EX7</b>	2G M2	1 M2	Gb Mb	 II 2G Ex ia IIC T6 Gb  I M2 Ex ia I Mb	Maximum current (Ii): 2.5 A Maximum voltage (Ui): 30 Vdc Conditional short circuit current: 1000 A acc. to EN 60947-5-1 Protection against short circuits: type gG fuse 4 A 250 V Pollution degree: 3	<b>⚠ This switch type must be used only in intrinsic safety circuits in compliance with standard IEC 60079-11, EN 60079-11</b>
<b>-EX8</b>	2D	21	Db	 II 2D Ex tb IIIC T80°C Db	Thermal current (I <sub>th</sub> ): 6 A Rated insulation voltage (U <sub>i</sub> ): 250 Vac/Vdc Conditional short circuit current: 1000 A acc. to EN 60947-5-1 Protection against short circuits: type aM fuse 6 A 500 V Pollution degree: 3	Alternating current: AC15 (50÷60 Hz) Ue (V) 250 Ie (A) 6 Direct current: DC13 Ue (V) 24 125 250 Ie (A) 3 0.55 0.3

**Quality marks of the product**

UL approval: E131787  
EAC approval: RU C-IT.YT03.B.00035/19

**Features approved by UL**

Electrical Ratings: Q300 pilot duty (69 VA, 125-250 V dc)  
A600 pilot duty (720 VA, 120-600 V ac)

Environmental Ratings: Types 1, 4X, 12, 13

For all contact blocks except 2 and 3 use 60 or 75°C copper (Cu) conductors, rigid or flexible, wire size 12, 14 AWG. Tightening torque for terminal screws of 7.1 lb in (0.8 Nm).

For contact blocks 2 and 3 use 60 or 75°C copper (Cu) conductors, rigid or flexible, wire size 14 AWG. Tightening torque for terminal screws of 12 lb in (1.4 Nm).

Please contact our technical department for the list of approved products.

**Adjustable levers**

For these switches the lever can be adjusted in 10° steps over the entire 360° range. The positive movement transmission

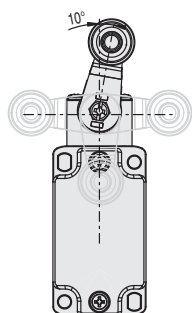

is always guaranteed thanks to the particular geometrical coupling between the lever and the revolving shaft as prescribed for safety applications by the German standard BG-GS-ET-15.

**Reversible levers**

With these switches, the lever can be secured in either the normal or reverse position, whereby positive coupling is retained.

In this way two different working planes of the lever are possible.

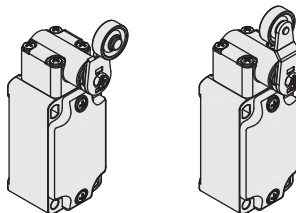
**Head with variable orientation**

For all switches the head can be rotated in 90° steps.

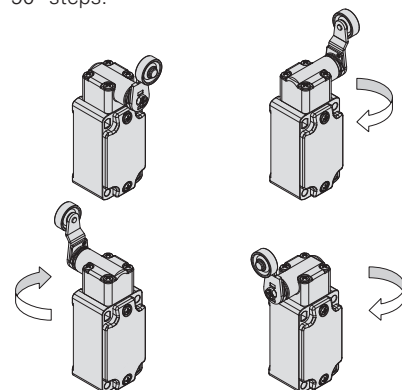
**Unidirectional heads**

For switches with swivelling lever, the unidirectional operation can be set by removing the four head screws and rotating the internal plunger.

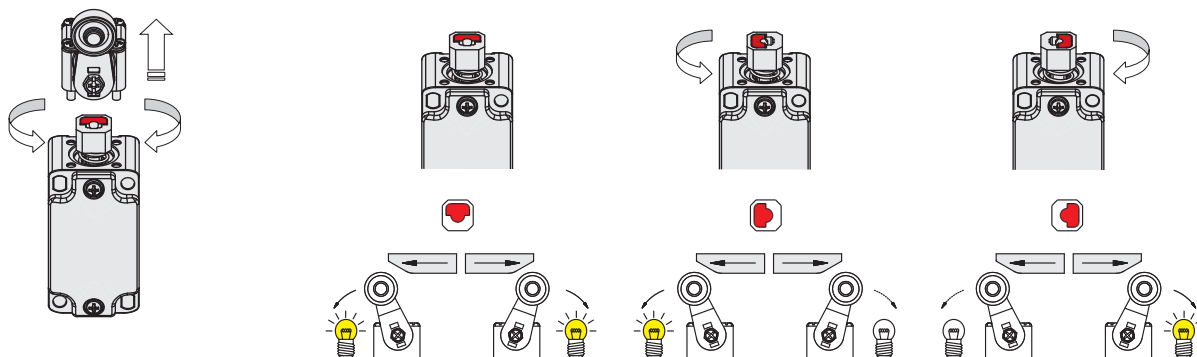
**Code structure**

**Attention!** The feasibility of a code number does not mean the effective availability of a product. Please contact our sales office.

article options product code extension  
**FD 502-GM2-EX7**

**Housing**  
FD metal, one conduit entry

**Contact block**  
5 1NO+1NC, snap action  
6 1NO+1NC, slow action  
7 1NO+1NC, slow action, make before break  
... ..

**Actuators**  
01 short plunger  
02 roller lever  
... ..

**ATEX approval**  
-EX4 Ex II 3D Ex tc IIIC T80°C Dc  
-EX7 Ex II 2G Ex ia IIC T6 Gb  
Ex I M2 Ex ia I Mb  
-EX8 Ex II 2D Ex tb IIIC T80°C Db

**Contact type**  
silver contacts (standard)  
G silver contacts, 1 µm gold coating  
G1 silver contacts, 2.5 µm gold coating (not for contact block 2, 20, 21, 22, 28, 29, 30)

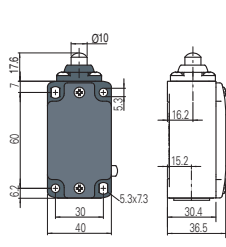
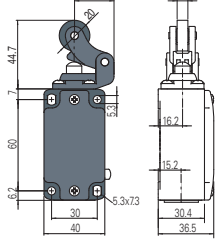
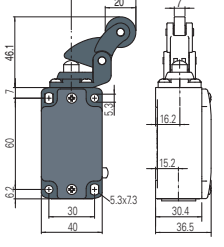
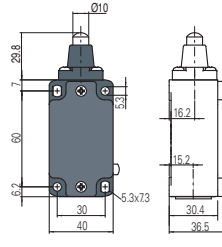
Contact type: <b>R</b> = snap action <b>L</b> = slow action		With steel roller with self-lubrication or 316L stainless steel on request		With steel roller with self-lubrication or 316L stainless steel on request			
Category	Contact block						
3D	2 <b>R</b>	FD 201-M2-EX4	2x(1NO-1NC)	FD 202-M2-EX4	2x(1NO-1NC)	FD 205-M2-EX4	2x(1NO-1NC)
	5 <b>R</b>	FD 501-M2-EX4	1NO+1NC	FD 502-M2-EX4	1NO+1NC	FD 505-M2-EX4	1NO+1NC
	6 <b>L</b>	FD 601-M2-EX4	1NO+1NC	FD 602-M2-EX4	1NO+1NC	FD 605-M2-EX4	1NO+1NC
	20 <b>L</b>	FD 2001-M2-EX4	1NO+2NC	FD 2002-M2-EX4	1NO+2NC	FD 2005-M2-EX4	1NO+2NC
2G M2	5 <b>R</b>	FD 501-M2-EX7	1NO+1NC	FD 502-M2-EX7	1NO+1NC	FD 505-M2-EX7	1NO+1NC
	20 <b>L</b>	FD 2001-M2-EX7	1NO+2NC	FD 2002-M2-EX7	1NO+2NC	FD 2005-M2-EX7	1NO+2NC
2D	5 <b>R</b>	FD 501-M2-EX8	1NO+1NC	FD 502-M2-EX8	1NO+1NC	FD 505-M2-EX8	1NO+1NC
	20 <b>L</b>	FD 2001-M2-EX8	1NO+2NC	FD 2002-M2-EX8	1NO+2NC	FD 2005-M2-EX8	1NO+2NC
Max. speed		0.5 m/s		0.5 m/s with cam at 30°		0.5 m/s with cam at 30°	
Actuating force		8 N (25 N ⊕)		6 N (25 N ⊕)		6 N (25 N ⊕)	
Travel diagrams		page 230 - group 1		page 230 - group 2		page 230 - group 2	

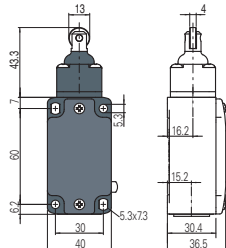
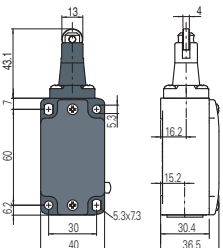
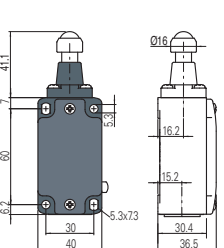
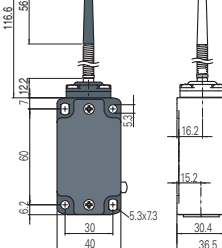
Contact type: <b>R</b> = snap action <b>L</b> = slow action		External gasket		Ball, Ø 12.7 mm, stainless steel		External gasket	
Category	Contact block						
3D	2 <b>R</b>	FD 215-M2-EX4	2x(1NO-1NC)	FD 216-M2-EX4	2x(1NO-1NC)	FD 219-M2-EX4	2x(1NO-1NC)
	5 <b>R</b>	FD 515-M2-EX4	1NO+1NC	FD 516-M2-EX4	1NO+1NC	FD 519-M2-EX4	1NO+1NC
	6 <b>L</b>	FD 615-M2-EX4	1NO+1NC	FD 616-M2-EX4	1NO+1NC	FD 619-M2-EX4	1NO+1NC
	20 <b>L</b>	FD 2015-M2-EX4	1NO+2NC	FD 2016-M2-EX4	1NO+2NC	FD 2019-M2-EX4	1NO+2NC
2G M2	5 <b>R</b>	FD 515-M2-EX7	1NO+1NC	FD 516-M2-EX7	1NO+1NC	FD 519-M2-EX7	1NO+1NC
	20 <b>L</b>	FD 2015-M2-EX7	1NO+2NC	FD 2016-M2-EX7	1NO+2NC	FD 2019-M2-EX7	1NO+2NC
2D	5 <b>R</b>	/		FD 516-M2-EX8	1NO+1NC	FD 519-M2-EX8	1NO+1NC
	20 <b>L</b>	/		FD 2016-M2-EX8	1NO+2NC	FD 2019-M2-EX8	1NO+2NC
Max. speed		0.5 m/s with cam at 30°		0.5 m/s with cam at 30°		0.5 m/s	
Actuating force		11 N (25 N ⊕)		8 N (25 N ⊕)		8 N (25 N ⊕)	
Travel diagrams		page 230 - group 1		page 230 - group 1		page 230 - group 1	

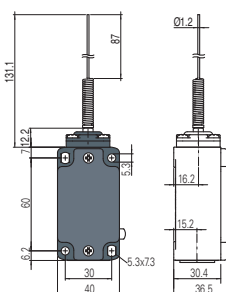
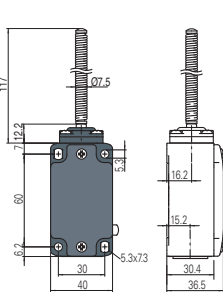
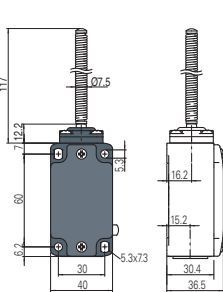
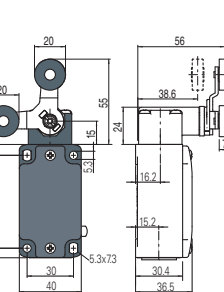
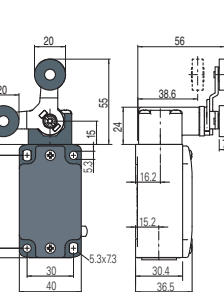
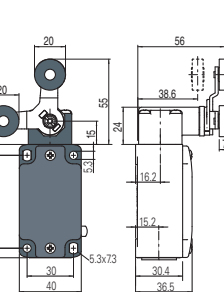
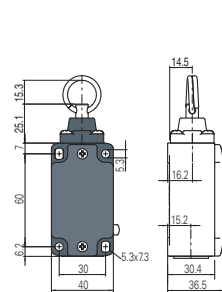
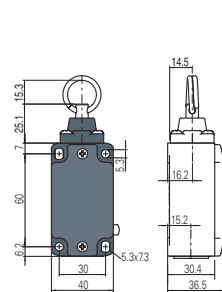
Contact type: <b>R</b> = snap action <b>L</b> = slow action		External gasket		External gasket		Bistable		Rope switch for signalling	
Category	Contact block								
3D	2 <b>R</b>	FD 221-M2-EX4	2x(1NO-1NC)	FD 225-M2-EX4	2x(1NO-1NC)	/	/	FD 276-M2-EX4	2x(1NO-1NC)
	5 <b>R</b>	FD 521-M2-EX4	1NO+1NC	FD 525-M2-EX4	1NO+1NC	FD 541-M2-EX4	1NO+1NC	FD 576-M2-EX4	1NO+1NC
	6 <b>L</b>	/		/		/		FD 676-M2-EX4	1NO+1NC
	20 <b>L</b>	FD 2021-M2-EX4	1NO+2NC	FD 2025-M2-EX4	1NO+2NC	/	/	FD 2076-M2-EX4	2NO+1NC
2G M2	5 <b>R</b>	FD 521-M2-EX7	1NO+1NC	FD 525-M2-EX7	1NO+1NC	FD 541-M2-EX7	1NO+1NC	FD 576-M2-EX7	1NO+1NC
	20 <b>L</b>	FD 2021-M2-EX7	1NO+2NC	FD 2025-M2-EX7	1NO+2NC	/	/	FD 2076-M2-EX7	2NO+1NC
2D	5 <b>R</b>	/		/		FD 541-M2-EX8	1NO+1NC	FD 576-M2-EX8	1NO+1NC
	20 <b>L</b>	/		/		/		FD 2076-M2-EX8	2NO+1NC
Max. speed		1 m/s		1 m/s		0.5 m/s with cam at 30°		0.5 m/s	
Actuating force		0.08 Nm		0.14 Nm		0.21 Nm (0.36 Nm ⊕)		initial 20 N - final 40 N	
Travel diagrams		page 230 - group 3		page 230 - group 3		page 230 - group 4		page 230 - group 6	

All values in the drawings are in mm

Accessories See page 207

The 2D and 3D files are available at [www.pizzato.com](http://www.pizzato.com)

## Position switches with swivelling lever without actuator

Contact type:

**R** = snap action  
**L** = slow action

Category	Contact block	Regular head		Compact head	
		28	41.5	28	31.1
3D	2 <b>R</b>	FD 238-M2-EX4	2x(1NO-1NC)	FD 258-M2-EX4	2x(1NO-1NC)
	5 <b>R</b>	FD 538-M2-EX4	1NO+1NC	FD 558-M2-EX4	1NO+1NC
	6 <b>L</b>	FD 638-M2-EX4	1NO+1NC	FD 658-M2-EX4	1NO+1NC
	20 <b>L</b>	FD 2038-M2-EX4	1NO+2NC	FD 2058-M2-EX4	1NO+2NC
2G M2	5 <b>R</b>	FD 538-M2-EX7	1NO+1NC	FD 558-M2-EX7	1NO+1NC
	20 <b>L</b>	FD 2038-M2-EX7	1NO+2NC	FD 2058-M2-EX7	1NO+2NC
2D	5 <b>R</b>	FD 538-M2-EX8	1NO+1NC	FD 558-M2-EX8	1NO+1NC
	20 <b>L</b>	FD 2038-M2-EX8	1NO+2NC	FD 2058-M2-EX8	1NO+2NC
Actuating force		0.1 Nm (0.25 Nm $\rightarrow$ )		0.06 Nm (0.25 Nm $\rightarrow$ )	
Travel diagrams		page 230 - group 4		page 230 - group 4	

### IMPORTANT

**For safety applications:** join only switches and actuators marked with symbol  $\rightarrow$  next to the product code.

For more information about safety applications see details on page 225.

## Separate actuators

**IMPORTANT:** These separate actuators can be used only with items of the FD series.

	Technopolymer roller Ø 20 mm	Adjustable round rod Ø 3x125 mm	Adjustable square rod, 3x3x125 mm	Spring rod with plastic tip	Adjustable actuator with techno- polymer roller	Adjustable glass fibre rod
Article	VF L31 $\rightarrow$	VF L32 <sup>(2)</sup>	VF L33 <sup>(2)</sup>	VF L34	VF L35 $\rightarrow$ <sup>(1) (2)</sup>	VF L36 <sup>(2)</sup>
Max. speed	1.5 m/s (cam at 30°)	1.5 m/s	1.5 m/s	1 m/s	1.5 m/s (cam at 30°)	1.5 m/s
	Technopolymer roller Ø 20 mm	Technopolymer roller Ø 20 mm	Porcelain roller	Adjustable safety actuator with technopolymer roller	Technopolymer roller Ø 20 mm	
Article	VF L51 $\rightarrow$	VF L52 $\rightarrow$	VF L53 $\rightarrow$	VF L56 $\rightarrow$ <sup>(2)</sup>	VF L57 $\rightarrow$	
Max. speed	1.5 m/s (cam at 30°)	1.5 m/s (cam at 30°)	0.5 m/s	1.5 m/s (cam at 30°)	1.5 m/s (cam at 30°)	
Steel rollers, Ø 20 mm, with self-lubrication						
Article	VF L31-R24 $\rightarrow$	VF L35-R24 $\rightarrow$ <sup>(1) (2)</sup>	VF L51-R24 $\rightarrow$	VF L52-R24 $\rightarrow$	VF L56-R24 $\rightarrow$ <sup>(2)</sup>	VF L57-R24 $\rightarrow$
Max. speed	1.5 m/s (cam at 30°)	1.5 m/s (cam at 30°)	1.5 m/s (cam at 30°)	1.5 m/s (cam at 30°)	1.5 m/s (cam at 30°)	1.5 m/s (cam at 30°)

**Note:** To order with 316L stainless steel roller: replace R24 with R41 in the order numbers.

- <sup>(1)</sup> Lever VF L35 can only be used in safety applications if adjusted to its max. length, as shown in the figure to the right.

If an adjustable lever is required for safety applications, use the VF L56 adjustable safety lever.

- <sup>(2)</sup> If installed with switch FD •58-M2-EX (e.g. FD 558-M2-EX•, FD 658-M2-EX•...) the actuator may hit the housing of the switch upon actuation. This possible interference depends on the fixing position of actuator and switch head.

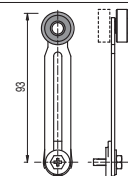









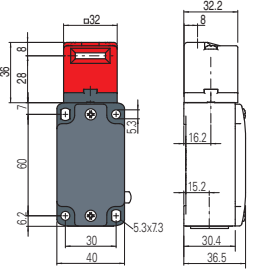
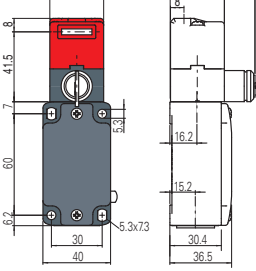
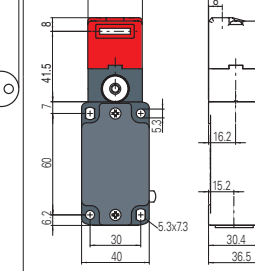

















All values in the drawings are in mm

Accessories See page 207

$\rightarrow$  The 2D and 3D files are available at [www.pizzato.com](http://www.pizzato.com)

## Safety switches with separate actuator

		Switches with separate actuator	Switches with separate actuator and key release	Switches with manual mechanical delay
		Switch without actuator	Switch without actuator	Switch without actuator
Contact type:  = slow action				
Category	Contact block	6  FD 693-M2-EX4  1NO+1NC	/	FD 6R2-M2-EX4  1NO+1NC
		18  /	FD 1899-M2-EX4  1NO+1NC	/
3D	20  FD 2093-M2-EX4  1NO+2NC	FD 2099-M2-EX4  1NO+2NC	FD 20R2-M2-EX4  1NO+2NC	
	28  /	FD 2899-M2-EX4  1NO+2NC	/	
2G M2	20  FD 2093-M2-EX7  1NO+2NC	FD 2099-M2-EX7  1NO+2NC	FD 20R2-M2-EX7  1NO+2NC	
	28  /	FD 2899-M2-EX7  1NO+2NC	/	
2D	20  FD 2093-M2-EX8  1NO+2NC	FD 2099-M2-EX8  1NO+2NC	FD 20R2-M2-EX8  1NO+2NC	
	28  /	FD 2899-M2-EX8  1NO+2NC	/	
Actuating force		10 N (18 N  )	30 N (40 N  )	10 N (18 N  )
Travel diagrams		see General Catalogue Safety 2023-2024	see General Catalogue Safety 2023-2024	see General Catalogue Safety 2023-2024









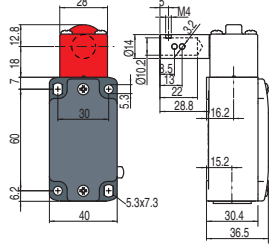

## Actuators



VF KEYF	VF KEYF1	VF KEYF2	VF KEYF3	VF KEYF7	VF KEYF8
Straight actuator	Angled actuator	Swivelling actuator	Actuator adjustable in two directions	Actuator adjustable in one direction	Universal actuator

**IMPORTANT:** These actuators can be used only with items of the FD series (e.g. FD 2093-M2-EX7).  
Actuators with low level of coding acc. to EN ISO 14119.

## Safety switches for hinges

		Switch without actuator
Contact type:  = slow action		
Category	Contact block	18  FD 1895-M2-EX4  1NO+1NC
		20  FD 2095-M2-EX4  1NO+2NC
2G M2	20  FD 2095-M2-EX7  1NO+2NC	
	20  FD 2095-M2-EX8  1NO+2NC	
Actuating force		0,15 Nm (0,4 Nm  )
Travel diagrams		see General Catalogue Safety 2023-2024

## Safety rope switches with reset for emergency stops

Contact type:

= slow action

Category	Contact block	Dimensions (mm)	Dimensions (mm)	Dimensions (mm)	Dimensions (mm)
3D	18  FD 1878-M2-EX4  1NO+1NC	14.5, 28, 65, 7, 6.2, 30, 36.5, 5.3x7.3, 16.2, 15.2, 30.4, 36.5	14.5, 28, 65, 7, 6.2, 30, 36.5, 5.3x7.3, 16.2, 15.2, 30.4, 36.5	14.5, 20, 84, 7, 6.2, 30, 36.5, 5.3x7.3, 16.2, 15.2, 30.4, 36.5	14.5, 20, 84, 7, 6.2, 30, 36.5, 5.3x7.3, 16.2, 15.2, 30.4, 36.5
	20  FD 2078-M2-EX4  1NO+2NC				
2G M2	20  FD 2078-M2-EX7  1NO+2NC				
	20  FD 2083-M2-EX7  1NO+2NC				
2D	18  FD 1878-M2-EX8  1NO+1NC				
	20  FD 2078-M2-EX8  1NO+2NC				
Actuating force	initial 63 N ... final 83 N (90 N )			initial 147 N ... final 235 N (250 N )	initial 147 N ... final 235 N (250 N )
Travel diagrams	see General Catalogue Safety 2023-2024			see General Catalogue Safety 2023-2024	see General Catalogue Safety 2023-2024

## Accessories for rope installation

VF AF-TR5	VF AF-TR8	VF AF-MR5	VF AF-ME78	VF AF-ME80	VF F05-100	VF AF-IF1GR11	VF AF-CA5	VF AF-CA10
Adjustable stay bolt	Stay bolt	End clamp	Safety spring for longitudinal heads	Safety spring for transversal heads	Rope coil Ø 5 mm length 100 m	Rope function indicator	Stainless steel pulley	Angular pulley, stainless steel

## Application examples and max. rope length

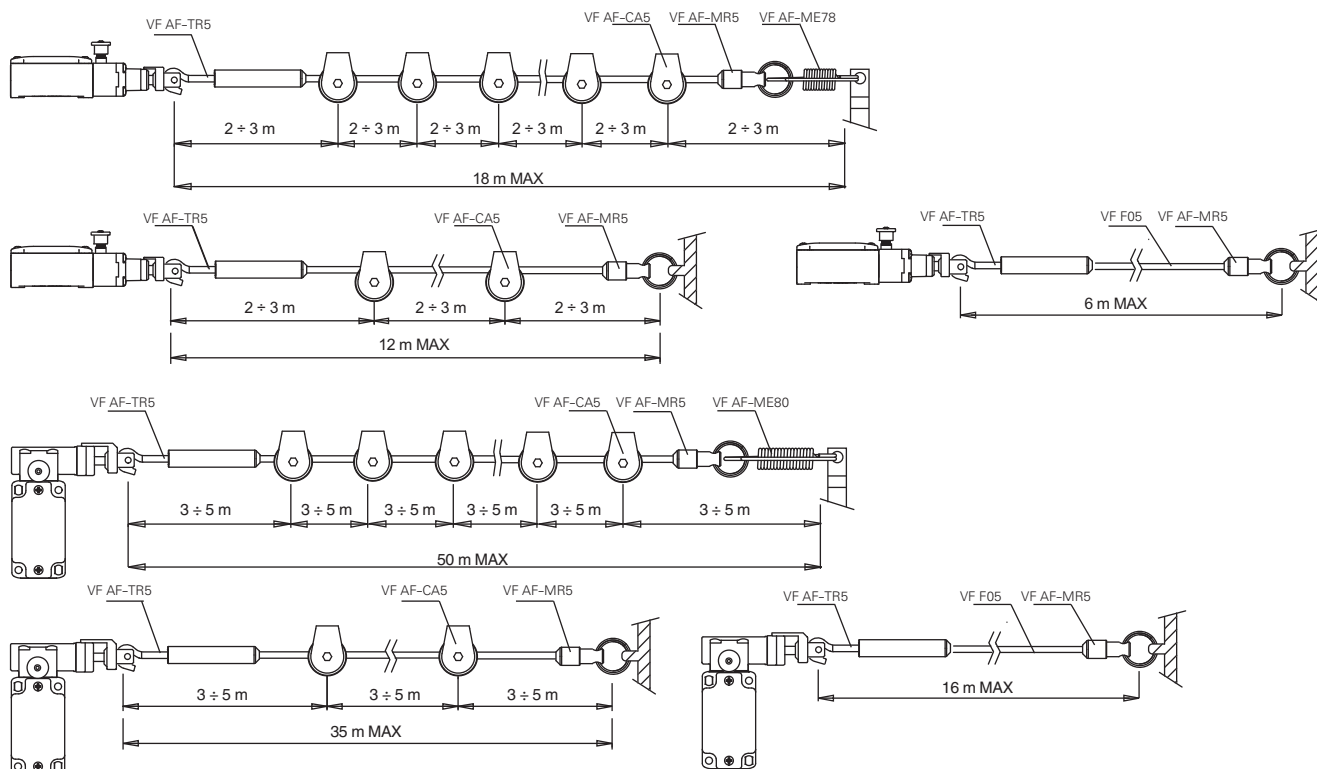

All values in the drawings are in mm

**Accessories** See page 207



 The 2D and 3D files are available at [www.pizzato.com](http://www.pizzato.com)



### Main features

- ATEX approval
- Metal housing, three conduit entries
- Protection degree IP66
- Versions with gold-plated silver contacts

### ATEX markings:

Product code extension	Quality mark	Certificate type and notified body
-EX4		EU declaration of conformity Pizzato Elettrica S.r.l.
-EX7		EU type examination certificate TÜV Italia
-EX8		EU type examination certificate: TÜV Italia

### Installation for safety applications:

Use only switches marked with the  symbol beside the product code. Always connect the safety circuit to the **NC contacts** (normally closed contacts: 11-12, 21-22 or 31-32) as required by **EN ISO 14119, paragraph 5.4** for specific interlock applications and **EN ISO 13849-2 tables D3** (well-tried components) and **D.8** (fault exclusions) for safety applications in general. Actuate the switch **at least up to the positive opening travel** shown in the travel diagrams on page 230. Actuate the switch **at least with the positive opening force**, reported in brackets below each article, next to the actuating force value.

**⚠ If not expressly indicated in this chapter, for correct installation and utilization of all articles see the instructions given in the registration certificate, in the operating manual and on pages 227 to 242.**

**⚠ For the correct use of the switch, please use appropriate cable glands suitable for the zone in compliance with the ATEX directive, see Accessories on page 183.**

### Technical data

#### Housing

Metal housing, powder-coated  
 Three threaded conduit entries: M20x1.5  
 Protection degree acc. to EN 60529: IP66 with cable gland of equal or higher protection degree

#### General data

Ambient temperature (-EX7): -20°C ... +60°C  
 Ambient temperature (-EX4/-EX8): -20°C ... +70°C  
 Max. actuation frequency: 3600 operating cycles/hour  
 Mechanical endurance:  
 FL ●●●-EX● 10 million operating cycles  
 FL ●●93-EX●, FL ●●78-EX●, FL ●●8●-EX●, FL ●●95-EX● 500,000 operating cycles  
 Mounting position: any  
 Safety parameters B<sub>10D</sub> (NC contacts):  
 FL ●●●-EX● 20,000,000  
 FL ●●93-EX●, FL ●●78-EX●, FL ●●8●-EX● 1,000,000  
 FL ●●95-EX● 2,500,000  
 Mechanical interlock, not coded: type 1 acc. to EN ISO 14119  
 Tightening torques for installation: see page 229  
 Wire cross-sections and wire stripping lengths: see page 249

#### Contact blocks available:

2, 3, 5, 6, 7, 8, 9, 10, 11, 12, 13, 14, 15, 16, 18, 20, 21, 22, 28, 29, 30, 33, 34, 37, 66, 67  
**Note:** contact blocks 2 and 3 are not available for articles FL ●●●-EX7, FL ●●●-EX8.

#### In compliance with standards:





IEC 60947-5-1, EN 60947-5-1, EN 60947-1, EN 50041, IEC 60204-1, EN 60204-1, EN ISO 14119, EN ISO 12100, IEC 60529, EN 60529, UL 508, CSA C22.2 No. 14, IEC 60079-0, EN 60079-0, IEC 60079-11, EN 60079-11, EN IEC 63000.

#### Compliance with the requirements of:

ATEX Directive 2014/34/EU, EMC Directive 2014/30/EU, RoHS Directive 2011/65/EU.

#### Positive contact opening in conformity with standards:

IEC 60947-5-1, EN 60947-5-1.

Product code extension	Category	Zone	EPL	Approvals	Electrical data	Utilization category
-EX4	3D	22	Dc	 II 3D Ex tc IIIC T80°C Dc	Thermal current (I <sub>th</sub> ): 10 A Rated insulation voltage (U <sub>i</sub> ): 500 Vac 600 Vdc 400 Vac for contact blocks 20, 28 Conditional short circuit current: 1000 A acc. to EN 60947-5-1 Protection against short circuits: type aM fuse 10 A 500 V Pollution degree: 3	Alternating current: AC15 (50÷60 Hz) Ue (V) 250 400 500 Ie (A) 6 4 1 Direct current: DC13 Ue (V) 24 125 250 Ie (A) 3 0.55 0.3
-EX7	2G M2	1 M2	Gb Mb	 II 2G Ex ia IIC T6 Gb  I M2 Ex ia I Mb	Maximum current (I <sub>i</sub> ): 2.5 A Maximum voltage (U <sub>i</sub> ): 30 Vdc Conditional short circuit current: 1000 A acc. to EN 60947-5-1 Protection against short circuits: type gG fuse 4 A 250 V Pollution degree: 3	<b>⚠ This switch type must be used only in intrinsic safety circuits in compliance with standard IEC 60079-11, EN 60079-11</b>
-EX8	2D	21	Db	 II 2D Ex tb IIIC T80°C Db	Thermal current (I <sub>th</sub> ): 6 A Rated insulation voltage (U <sub>i</sub> ): 250 Vac/Vdc Conditional short circuit current: 1000 A acc. to EN 60947-5-1 Protection against short circuits: type aM fuse 6 A 500 V Pollution degree: 3	Alternating current: AC15 (50÷60 Hz) Ue (V) 250 Ie (A) 6 Direct current: DC13 Ue (V) 24 125 250 Ie (A) 3 0.55 0.3



### Quality marks of the product



UL approval: E131787  
EAC approval: RU C-IT.YT03.B.00035/19

### Features approved by UL

Electrical Ratings: Q300 pilot duty (69 VA, 125-250 V dc)  
A600 pilot duty (720 VA, 120-600 V ac)

Environmental Ratings: Types 1, 4X, 12, 13

For all contact blocks except 2 and 3 use 60 or 75°C copper (Cu) conductors, rigid or flexible, wire size 12, 14 AWG. Tightening torque for terminal screws of 7.1 lb in (0.8 Nm).

For contact blocks 2 and 3 use 60 or 75°C copper (Cu) conductors, rigid or flexible, wire size 14 AWG. Tightening torque for terminal screws of 12 lb in (1.4 Nm).

Please contact our technical department for the list of approved products.

### Adjustable levers

For switches with swivelling lever, the lever can be adjusted in 10° steps over the entire 360° range. The positive movement transmission is always guaranteed thanks to the particular geometrical coupling between the lever and the revolving shaft as prescribed for safety applications by the German standard BG-GS-ET-15.

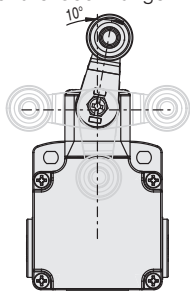

### Reversible levers

For switches with swivelling lever, the lever can be fastened on straight or reverse side maintaining the positive coupling. In this way two different working planes of the lever are possible.

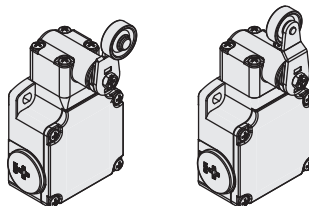

### Head with variable orientation

For all switches the head can be rotated in 90° steps.

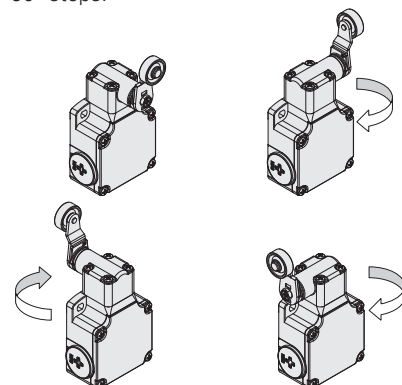

### Unidirectional heads

For switches with swivelling lever, the unidirectional operation can be set by removing the four head screws and rotating the internal plunger (except contact block 16).

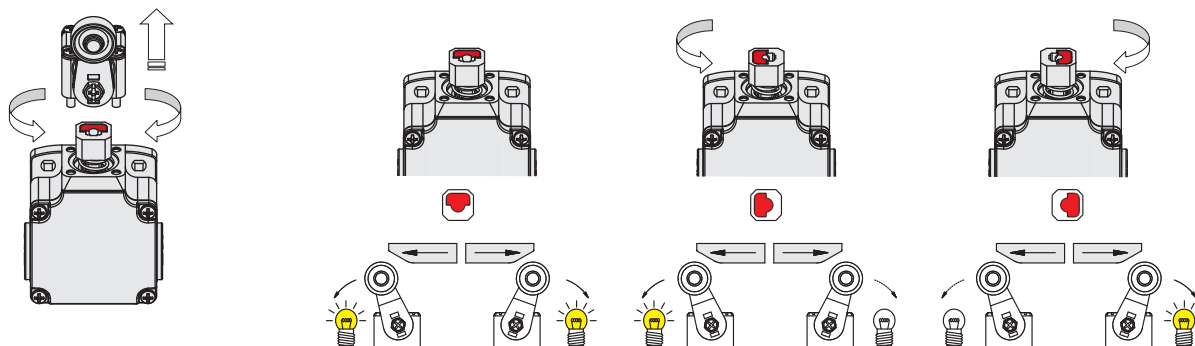

### Code structure

**Attention!** The feasibility of a code number does not mean the effective availability of a product. Please contact our sales office.

article options product code extension  
**FL 502-GM2-EX7**

Housing	
<b>FL</b>	metal, three conduit entries
Contact block	
<b>5</b>	1NO+1NC, snap action
<b>6</b>	1NO+1NC, slow action
<b>7</b>	1NO+1NC, slow action, make before break
...	...

Actuators	
<b>01</b>	short plunger
<b>02</b>	roller lever
...	...

ATEX approval	
<b>-EX4</b>	Ex II 3D Ex tc IIIC T80°C Dc
<b>-EX7</b>	Ex II 2G Ex ia IICT6 Gb Ex I M2 Ex ia I Mb
<b>-EX8</b>	Ex II 2D Ex tb IIIC T80°C Db

Contact type	
	silver contacts (standard)
<b>G</b>	silver contacts, 1 µm gold coating
<b>G1</b>	silver contacts, 2.5 µm gold coating (not for contact block 2, 20, 21, 22, 28, 29, 30)

# Switches compliant with ATEX directive / FL series

Contact type:  
**R** = snap action  
**L** = slow action

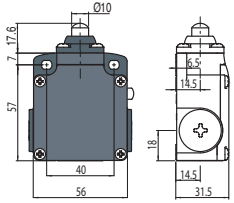
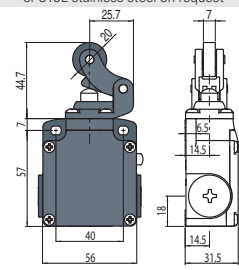
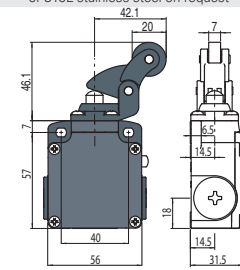
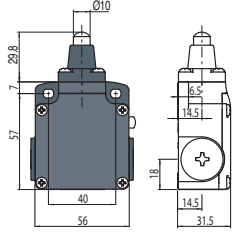
Category	Contact block	With steel roller with self-lubrication or 316L stainless steel on request		With steel roller with self-lubrication or 316L stainless steel on request		With steel roller with self-lubrication or 316L stainless steel on request	
							
3D	2 <b>R</b>	FL 201-M2-EX4	2x(1NO-1NC)	FL 202-M2-EX4	2x(1NO-1NC)	FL 205-M2-EX4	2x(1NO-1NC)
	5 <b>R</b>	FL 501-M2-EX4	1NO+1NC	FL 502-M2-EX4	1NO+1NC	FL 505-M2-EX4	1NO+1NC
	6 <b>L</b>	FL 601-M2-EX4	1NO+1NC	FL 602-M2-EX4	1NO+1NC	FL 605-M2-EX4	1NO+1NC
	20 <b>L</b>	FL 2001-M2-EX4	1NO+2NC	FL 2002-M2-EX4	1NO+2NC	FL 2005-M2-EX4	1NO+2NC
2G M2	5 <b>R</b>	FL 501-M2-EX7	1NO+1NC	FL 502-M2-EX7	1NO+1NC	FL 505-M2-EX7	1NO+1NC
	20 <b>L</b>	FL 2001-M2-EX7	1NO+2NC	FL 2002-M2-EX7	1NO+2NC	FL 2005-M2-EX7	1NO+2NC
2D	5 <b>R</b>	FL 501-M2-EX8	1NO+1NC	FL 502-M2-EX8	1NO+1NC	FL 505-M2-EX8	1NO+1NC
	20 <b>L</b>	FL 2001-M2-EX8	1NO+2NC	FL 2002-M2-EX8	1NO+2NC	FL 2005-M2-EX8	1NO+2NC
Max. speed		0.5 m/s		0.5 m/s with cam at 30°		0.5 m/s with cam at 30°	
Actuating force		8 N (25 N ⊕)		6 N (25 N ⊕)		6 N (25 N ⊕)	
Travel diagrams		page 230 - group 1		page 230 - group 2		page 230 - group 2	

Contact type:  
**R** = snap action  
**L** = slow action

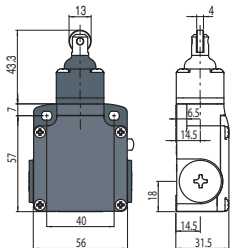
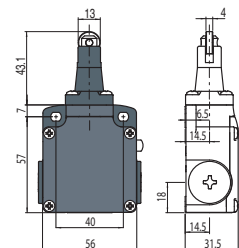
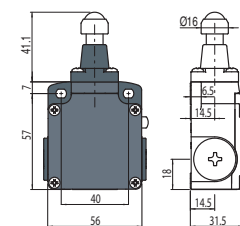
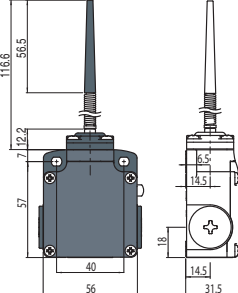
Category	Contact block	External gasket		Ball, Ø 12.7 mm, stainless steel		External gasket	
							
3D	2 <b>R</b>	FL 215-M2-EX4	2x(1NO-1NC)	FL 216-M2-EX4	2x(1NO-1NC)	FL 219-M2-EX4	2x(1NO-1NC)
	5 <b>R</b>	FL 515-M2-EX4	1NO+1NC	FL 516-M2-EX4	1NO+1NC	FL 519-M2-EX4	1NO+1NC
	6 <b>L</b>	FL 615-M2-EX4	1NO+1NC	FL 616-M2-EX4	1NO+1NC	FL 619-M2-EX4	1NO+1NC
	20 <b>L</b>	FL 2015-M2-EX4	1NO+2NC	FL 2016-M2-EX4	1NO+2NC	FL 2019-M2-EX4	1NO+2NC
2G M2	5 <b>R</b>	FL 515-M2-EX7	1NO+1NC	FL 516-M2-EX7	1NO+1NC	FL 519-M2-EX7	1NO+1NC
	20 <b>L</b>	FL 2015-M2-EX7	1NO+2NC	FL 2016-M2-EX7	1NO+2NC	FL 2019-M2-EX7	1NO+2NC
2D	5 <b>R</b>	/		FL 516-M2-EX8	1NO+1NC	FL 519-M2-EX8	1NO+1NC
	20 <b>L</b>	/		FL 2016-M2-EX8	1NO+2NC	FL 2019-M2-EX8	1NO+2NC
Max. speed		0.5 m/s with cam at 30°		0.5 m/s with cam at 30°		0.5 m/s	
Actuating force		11 N (25 N ⊕)		8 N (25 N ⊕)		8 N (25 N ⊕)	
Travel diagrams		page 230 - group 1		page 230 - group 1		page 230 - group 1	

Contact type:  
**R** = snap action  
**L** = slow action

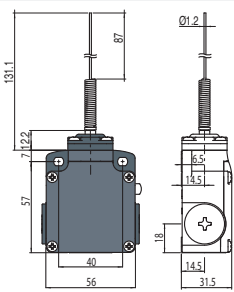
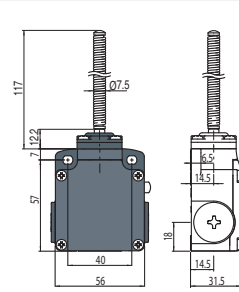
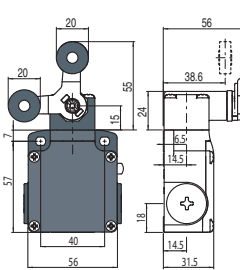
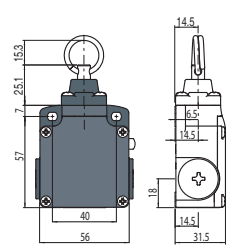
Category	Contact block	External gasket		External gasket		Bistable		Rope switch for signalling	
									
3D	2 <b>R</b>	FL 221-M2-EX4	2x(1NO-1NC)	FL 225-M2-EX4	2x(1NO-1NC)	/	/	FL 276-M2-EX4	2x(1NO-1NC)
	5 <b>R</b>	FL 521-M2-EX4	1NO+1NC	FL 525-M2-EX4	1NO+1NC	FL 541-M2-EX4	1NO+1NC	FL 576-M2-EX4	1NO+1NC
	6 <b>L</b>	/		/		/		FL 676-M2-EX4	1NO+1NC
	20 <b>L</b>	FL 2021-M2-EX4	1NO+2NC	FL 2025-M2-EX4	1NO+2NC	/	/	FL 2076-M2-EX4	2NO+1NC
2G M2	5 <b>R</b>	FL 521-M2-EX7	1NO+1NC	FL 525-M2-EX7	1NO+1NC	FL 541-M2-EX7	1NO+1NC	FL 576-M2-EX7	1NO+1NC
	20 <b>L</b>	FL 2021-M2-EX7	1NO+2NC	FL 2025-M2-EX7	1NO+2NC	/	/	FL 2076-M2-EX7	2NO+1NC
2D	5 <b>R</b>	/		/		FL 541-M2-EX8	1NO+1NC	FL 576-M2-EX8	1NO+1NC
	20 <b>L</b>	/		/		/		FL 2076-M2-EX8	2NO+1NC
Max. speed		1 m/s		1 m/s		0.5 m/s with cam at 30°		0.5 m/s	
Actuating force		0.08 Nm		0.14 Nm		0.21 Nm (0.36 Nm ⊕)		initial 20 N - final 40 N	
Travel diagrams		page 230 - group 3		page 230 - group 3		page 230 - group 4		page 230 - group 6	

All values in the drawings are in mm

Accessories See page 207

→ The 2D and 3D files are available at [www.pizzato.com](http://www.pizzato.com)

## Position switches with swivelling lever without actuator

Contact type:

**R** = snap action  
**L** = slow action

Category	Contact block	Regular head		Compact head	
		FL 238-M2-EX4	FL 538-M2-EX4	FL 258-M2-EX4	FL 558-M2-EX4
3D	2 <b>R</b>	2x(1NO-1NC)	2x(1NO-1NC)	2x(1NO-1NC)	2x(1NO-1NC)
	5 <b>R</b>	1NO+1NC	1NO+1NC	1NO+1NC	1NO+1NC
	6 <b>L</b>	1NO+1NC	1NO+1NC	1NO+1NC	1NO+1NC
	20 <b>L</b>	1NO+2NC	1NO+2NC	1NO+2NC	1NO+2NC
2G M2	5 <b>R</b>	1NO+1NC	1NO+1NC	1NO+1NC	1NO+1NC
	20 <b>L</b>	1NO+2NC	1NO+2NC	1NO+2NC	1NO+2NC
2D	5 <b>R</b>	1NO+1NC	1NO+1NC	1NO+1NC	1NO+1NC
	20 <b>L</b>	1NO+2NC	1NO+2NC	1NO+2NC	1NO+2NC
Actuating force		0.1 Nm (0.25 Nm $\ominus$ )		0.06 Nm (0.25 Nm $\ominus$ )	
Travel diagrams		page 230 - group 4		page 230 - group 4	

### IMPORTANT

**For safety applications:** join only switches and actuators marked with symbol  $\ominus$  next to the product code. For more information about safety applications see details on page 225.

## Separate actuators

**IMPORTANT:** These separate actuators can be used only with items of the FL series.

	Technopolymer roller Ø 20 mm	Adjustable round rod Ø 3x125 mm	Adjustable square rod, 3x3x125 mm	Spring rod with plastic tip	Adjustable actuator with technopolymer roller	Adjustable glass fibre rod
Article	<b>VF L31</b> $\ominus$	<b>VF L32</b> <sup>(2)</sup>	<b>VF L33</b> <sup>(2)</sup>	<b>VF L34</b>	<b>VF L35</b> $\ominus$ <sup>(1) (2)</sup>	<b>VF L36</b> <sup>(2)</sup>
Max. speed	1.5 m/s (cam at 30°)	1.5 m/s	1.5 m/s	1 m/s	1.5 m/s (cam at 30°)	1.5 m/s
	Technopolymer roller Ø 20 mm	Technopolymer roller Ø 20 mm	Porcelain roller	Adjustable safety actuator with technopolymer roller	Technopolymer roller Ø 20 mm	
Article	<b>VF L51</b> $\ominus$	<b>VF L52</b> $\ominus$	<b>VF L53</b> $\ominus$	<b>VF L56</b> $\ominus$ <sup>(2)</sup>	<b>VF L57</b> $\ominus$	
Max. speed	1.5 m/s (cam at 30°)	1.5 m/s (cam at 30°)	0.5 m/s	1.5 m/s (cam at 30°)	1.5 m/s (cam at 30°)	
Steel rollers, Ø 20 mm, with self-lubrication						
Article	<b>VF L31-R24</b> $\ominus$	<b>VF L35-R24</b> $\ominus$ <sup>(1) (2)</sup>	<b>VF L51-R24</b> $\ominus$	<b>VF L52-R24</b> $\ominus$	<b>VF L56-R24</b> $\ominus$ <sup>(2)</sup>	<b>VF L57-R24</b> $\ominus$
Max. speed	1.5 m/s (cam at 30°)	1.5 m/s (cam at 30°)	1.5 m/s (cam at 30°)	1.5 m/s (cam at 30°)	1.5 m/s (cam at 30°)	1.5 m/s (cam at 30°)

**Note:** To order with 316L stainless steel roller: replace R24 with R41 in the order numbers.







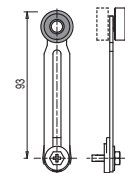

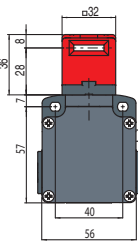
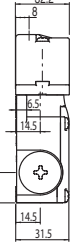

- <sup>(1)</sup> Lever VF L35 can only be used in safety applications if adjusted to its max. length, as shown in the figure to the right.

If an adjustable lever is required for safety applications, use the VF L56 adjustable safety lever.

- <sup>(2)</sup> If installed with switch FL •58-M2-EX (e.g. FL 558-M2-EX•, FL 658-M2-EX•...) the actuator may hit the housing of the switch upon actuation. This possible interference depends on the fixing position of actuator and switch head.



## Safety switches with separate actuator

		Switches with separate actuator	
		Switch without actuator	
Contact type:  = slow action			
Category	Contact block		
3D	6 	FL 693-M2-EX4	 1NO+1NC
	20 	FL 2093-M2-EX4	 1NO+2NC
2G M2	20 	FL 2093-M2-EX7	 1NO+2NC
2D	20 	FL 2093-M2-EX8	 1NO+2NC
Actuating force	10 N (18 N  )		
Travel diagrams	see General Catalogue Safety 2023-2024		



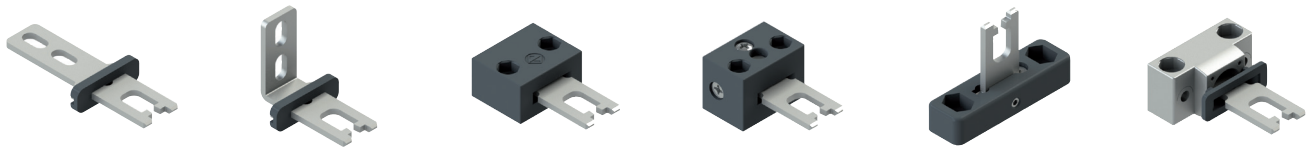





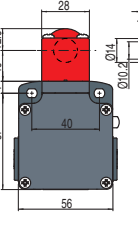
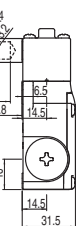

## Actuators



VF KEYF	VF KEYF1	VF KEYF2	VF KEYF3	VF KEYF7	VF KEYF8
Straight actuator	Angled actuator	Swivelling actuator	Actuator adjustable in two directions	Actuator adjustable in one direction	Universal actuator

**IMPORTANT:** These actuators can be used only with items of the FL series (e.g. FL 2093-M2-EX7).  
Actuators with low level of coding acc. to EN ISO 14119.

## Safety switches for hinges

		Switches with separate actuator	
Contact type:  = slow action			
Category	Contact block		
3D	18 	FL 1895-M2-EX4	 1NO+1NC
	20 	FL 2095-M2-EX4	 1NO+2NC
2G M2	20 	FL 2095-M2-EX7	 1NO+2NC
2D	20 	FL 2095-M2-EX8	 1NO+2NC
Actuating force	0,15 Nm (0,4 Nm  )		
Travel diagrams	see General Catalogue Safety 2023-2024		

## Safety rope switches with reset for emergency stops

Contact type:

= slow action

Category	Contact block	Dimensions (mm)	Dimensions (mm)	Dimensions (mm)	Dimensions (mm)	
3D	18  FL 1878-M2-EX4  1NO+1NC	66, 28, 7, 57, 40, 56	14.5, 28, 16.7-20.2, 14.5, 31.5, 18	84, 20, 14.5, 30.8-34.3, 14.5, 15, 7, 57, 40, 56	14.5, 30.8-34.3, 14.5, 15, 7, 57, 40, 56	
	20  FL 2078-M2-EX4  1NO+2NC					
2G M2	20  FL 2078-M2-EX7  1NO+2NC					
	FL 2083-M2-EX4  1NO+1NC					
	FL 2083-M2-EX7  1NO+2NC					
	FL 2084-M2-EX4  1NO+2NC					
	FL 2084-M2-EX7  1NO+2NC					
2D	18  FL 1878-M2-EX8  1NO+1NC					
	20  FL 2078-M2-EX8  1NO+2NC					
	FL 1883-M2-EX8  1NO+1NC					
	FL 2083-M2-EX8  1NO+2NC					
	FL 1884-M2-EX8  1NO+1NC					
	FL 2084-M2-EX8  1NO+2NC					
Actuating force	initial 63 N ... final 83 N (90 N )		initial 147 N ... final 235 N (250 N )		initial 147 N ... final 235 N (250 N )	
Travel diagrams	see General Catalogue Safety 2023-2024		see General Catalogue Safety 2023-2024		see General Catalogue Safety 2023-2024	

## Accessories for rope installation

VF AF-TR5	VF AF-TR8	VF AF-MR5	VF AF-ME78	VF AF-ME80	VF F05-100	VF AF-IF1GR11	VF AF-CA5	VF AF-CA10
Adjustable stay bolt	Stay bolt	End clamp	Safety spring for longitudinal heads	Safety spring for transversal heads	Rope coil Ø 5 mm length 100 m	Rope function indicator.	Stainless steel pulley	Angular pulley, stainless steel

## Application examples and max. rope length

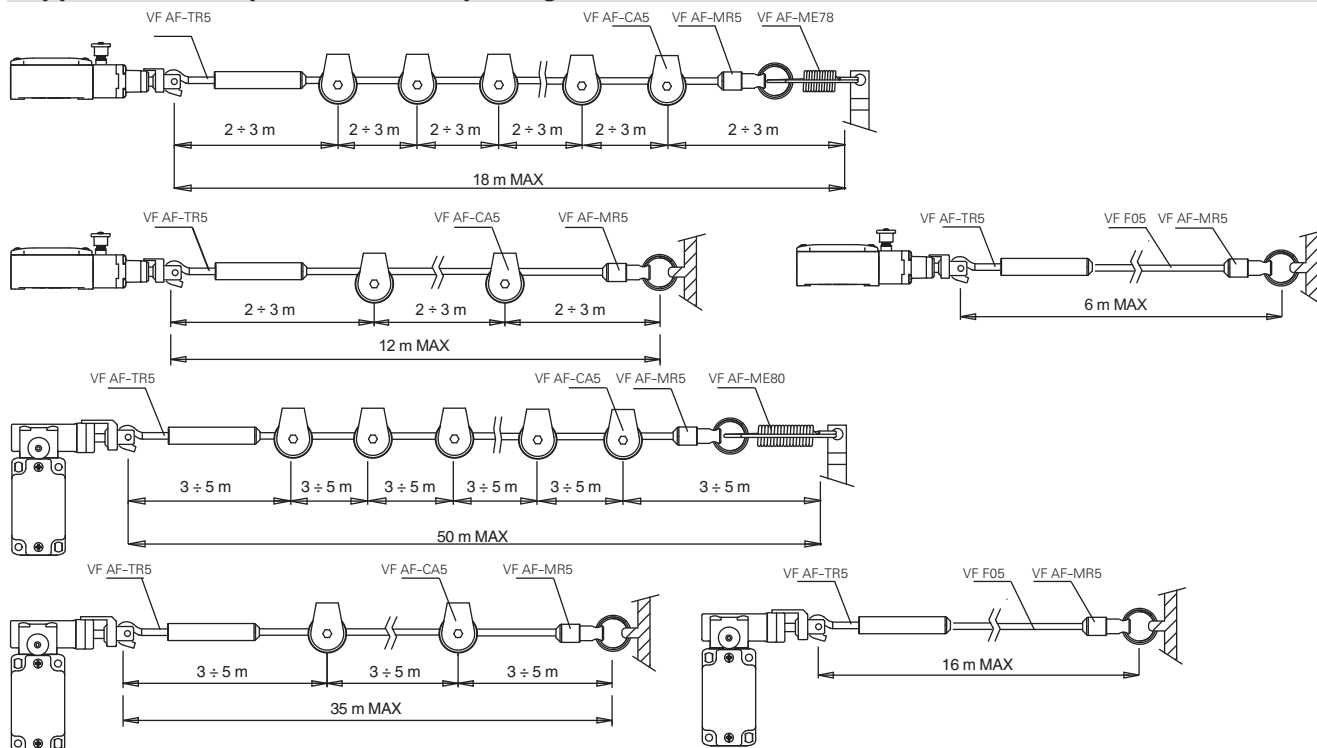

All values in the drawings are in mm

**Accessories** See page 207

 The 2D and 3D files are available at [www.pizzato.com](http://www.pizzato.com)



### Main features

- ATEX approval
- Metal housing, one conduit entry
- Protection degree IP67
- Versions with gold-plated silver contacts

### ATEX markings:

Product code extension

Quality mark

Certificate type and notified body

**-EX7**



EU type examination certificate  
TUV Italia

### Technical data

#### Housing

Metal housing, powder-coated	
One threaded conduit entry:	M20x1.5
Protection degree:	IP67 acc. to EN 60529 (with cable gland of equal or higher protection degree)

#### General data

Ambient temperature:	-20°C ... +60°C
Max. actuation frequency:	3600 operating cycles/hour
Mechanical endurance:	
FM ●●●●-EX●	10 million operating cycles
FM ●●C●-EX●, FM ●●96-EX●	500,000 operating cycles
Mounting position:	any
Safety parameters B <sub>10D</sub> (NC contacts):	
FM ●●●●-EX●	20,000,000
FM ●●C●-EX●	1,000,000
FM ●●96-EX●	2,500,000
Mechanical interlock, not coded:	type 1 acc. to EN ISO 14119
Tightening torques for installation:	see page 231
Wire cross-sections and wire stripping lengths:	see page 249

#### Contact blocks available:

5, 6, 7, 8, 9, 10, 11, 12, 13, 14, 15, 16, 18, 20, 21, 22, 28, 29, 30, 33, 34, 37, 66, 67

#### In compliance with standards:

IEC 60947-5-1, EN 60947-5-1, EN 60947-1, EN 50047, IEC 60204-1, EN 60204-1, EN ISO 14119, EN ISO 12100, IEC 60529, EN 60529, UL 508, CSA C22.2 No. 14, IEC 60079-0, EN 60079-0, IEC 60079-11, EN 60079-11, EN IEC 63000.

#### Compliance with the requirements of:

ATEX Directive 2014/34/EU, EMC Directive 2014/30/EU, RoHS Directive 2011/65/EU.

#### Positive contact opening in conformity with standards:

IEC 60947-5-1, EN 60947-5-1.

### Installation for safety applications:

Use only switches marked with the  symbol beside the product code. Always connect the safety circuit to the **NC contacts** (normally closed contacts: 11-12, 21-22 or 31-32) as required by **EN ISO 14119, paragraph 5.4** for specific interlock applications and **EN ISO 13849-2 tables D3** (well-tried components) and **D.8** (fault exclusions) for safety applications in general. Actuate the switch **at least up to the positive opening travel** shown in the travel diagrams on page 232. Actuate the switch **at least with the positive opening force**, reported in brackets below each article, next to the actuating force value.

 **If not expressly indicated in this chapter, for correct installation and utilization of all articles see the instructions given in the registration certificate, in the operating manual and on pages 227 to 242.**

 **For the correct use of the switch, please use appropriate cable glands suitable for the zone in compliance with the ATEX directive, see Accessories on page 183.**

Category	Zone	EPL	Approvals
2G M2	1 M2	Gb Mb	II 2G Ex ia IIC T6 Gb I M2 Ex ia I Mb
Product code extension <b>-EX7</b>	<b>Electrical data</b>		<p> This switch type must be used only in intrinsic safety circuits in compliance with standard IEC 60079-11, EN 60079-11</p> <p>Maximum current (Ii): 2.5 A Maximum voltage (Ui): 30 Vdc Conditional short circuit current: 1000 A acc. to EN 60947-5-1 Protection against short circuits: type gG fuse 4 A 250 V Pollution degree: 3</p>

**Quality marks of the product**

UL approval: E131787  
 EAC approval: RU C-IT.YT03.B.00035/19

**Features approved by UL**

Electrical Ratings: Q300 pilot duty (69 VA, 125-250 V dc)  
 A600 pilot duty (720 VA, 120-600 V ac)  
 Environmental Ratings: Types 1, 4X, 12, 13  
 For all contact blocks except 2 and 3 use 60 or 75°C copper (Cu) conductors, rigid or flexible, wire size 12, 14 AWG. Tightening torque for terminal screws of 7.1 lb in (0.8 Nm).  
 For contact blocks 2 and 3 use 60 or 75°C copper (Cu) conductors, rigid or flexible, wire size 14 AWG. Tightening torque for terminal screws of 12 lb in (1.4 Nm).

Please contact our technical department for the list of approved products.

**Adjustable levers**

For these switches the lever can be adjusted in 10° steps over the entire 360° range. The positive movement transmission is always guaranteed thanks to the particular geometrical coupling between the lever and the revolving shaft as prescribed for safety applications by the German standard BG-GS-ET-15.

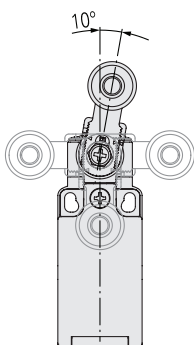
**Reversible levers**

With these switches, the lever can be secured in either the normal or reverse position, whereby positive coupling is retained. In this way two different working planes of the lever are possible.

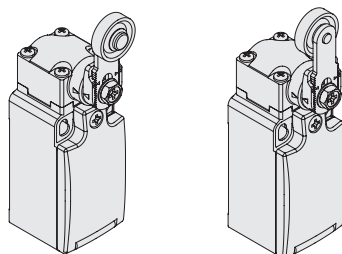
**Head with variable orientation**

For all switches the head can be rotated in 90° steps.

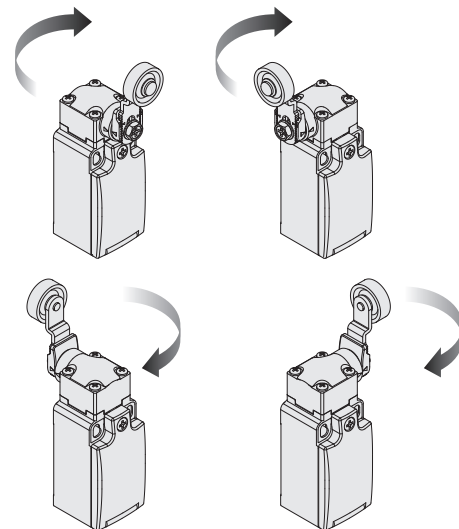
**Code structure**

**Attention!** The feasibility of a code number does not mean the effective availability of a product. Please contact our sales office.

article options product code extension  
**FM 502-GM2-EX7**

Housing	
<b>FM</b>	metal, one conduit entry











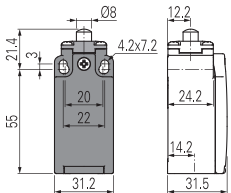
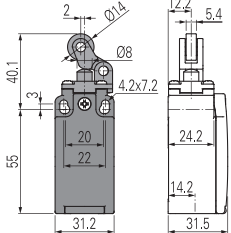
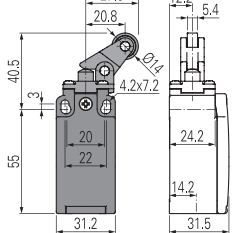
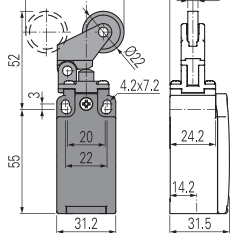

Contact block	
<b>5</b>	1NO+1NC, snap action
<b>11</b>	2NC, snap action
<b>12</b>	2NO, snap action
<b>20</b>	1NO+2NC, slow action
<b>21</b>	3NC, slow action
<b>22</b>	2NO+1NC, slow action

Actuators	
<b>01</b>	short plunger
<b>02</b>	roller lever
...	...











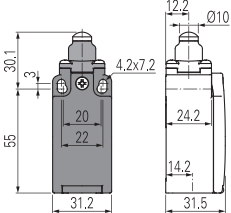
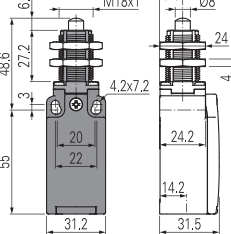
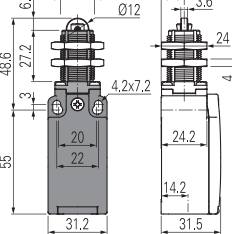
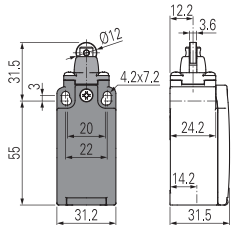

ATEX approval	
<b>-EX7</b>	II 2G Ex ia IIC T6 Gb I M2 Ex ia I Mb

Contact type	
	silver contacts (standard)
<b>G</b>	silver contacts, 1 µm gold coating
<b>G1</b>	silver contacts, 2.5 µm gold coating (not for contact block 20, 21, 22, 28, 29, 30, 33, 34)

Contact type:  
**R** = snap action  
**L** = slow action

Category	Contact block	With steel roller with self-lubrication or 316L stainless steel on request	With steel roller with self-lubrication or 316L stainless steel on request	With steel roller with self-lubrication or 316L stainless steel on request	With steel roller with self-lubrication or 316L stainless steel on request	
2G M2	5 <b>R</b>					
	20 <b>L</b>	<b>FM 501-M2-EX7</b>  1NO+1NC <b>FM 2001-M2-EX7</b>  1NO+2NC	<b>FM 502-M2-EX7</b>  1NO+1NC <b>FM 2002-M2-EX7</b>  1NO+2NC	<b>FM 505-M2-EX7</b>  1NO+1NC <b>FM 2005-M2-EX7</b>  1NO+2NC	<b>FM 507-M2-EX7</b>  1NO+1NC <b>FM 2007-M2-EX7</b>  1NO+2NC	
Max. speed	0.5 m/s		0.5 m/s with cam at 30°		0.5 m/s with cam at 30°	
Actuating force	8 N (25 N  )		6 N (25 N  )		4 N (25 N  )	
Travel diagrams	page 232 - group 1		page 232 - group 2		page 232 - group 3	

Contact type:  
**R** = snap action  
**L** = slow action

Category	Contact block	External gasket	External gasket	External gasket	External gasket	
2G M2	5 <b>R</b>					
	20 <b>L</b>	<b>FM 508-M2-EX7</b>  1NO+1NC <b>FM 2008-M2-EX7</b>  1NO+2NC	<b>FM 512-M2-EX7</b>  1NO+1NC <b>FM 2012-M2-EX7</b>  1NO+2NC	<b>FM 513-M2-EX7</b>  1NO+1NC <b>FM 2013-M2-EX7</b>  1NO+2NC	<b>FM 515-M2R28-EX7</b>  1NO+1NC <b>FM 2015-M2R28-EX7</b>  1NO+2NC	
Max. speed	0.5 m/s		0.5 m/s		0.5 m/s with cam at 30°	
Actuating force	8 N (25 N  )		8 N (25 N  )		8 N (25 N  )	
Travel diagrams	page 232 - group 1		page 232 - group 1		page 232 - group 1	

Contact type:  
**R** = snap action  
**L** = slow action

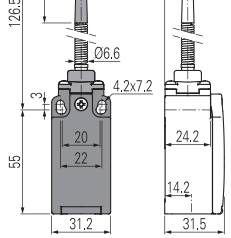
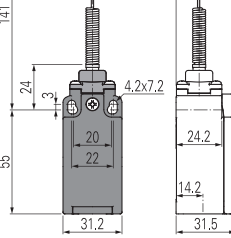
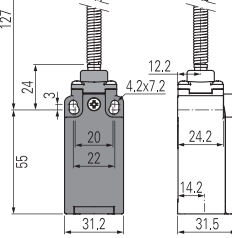
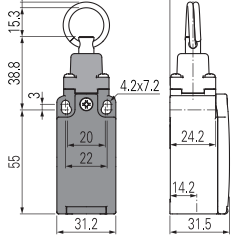
Category	Contact block	External gasket	External gasket	External gasket	Rope switch for signalling	
2G M2	5 <b>R</b>					
	20 <b>L</b>	<b>FM 520-M2-EX7</b> 1NO+1NC <b>FM 2020-M2-EX7</b> 1NO+2NC	<b>FM 521-M2-EX7</b> 1NO+1NC <b>FM 2021-M2-EX7</b> 1NO+2NC	<b>FM 525-M2-EX7</b> 1NO+1NC <b>FM 2025-M2-EX7</b> 1NO+2NC	<b>FM 576-M2-EX7</b> 1NO+1NC <b>FM 2076-M2-EX7</b> 2NO+1NC	
Max. speed	1 m/s		1 m/s		0.5 m/s	
Actuating force	0.06 Nm		0.04 Nm		initial 20 N - final 40 N	
Travel diagrams	page 232 - group 4		page 232 - group 4		page 232 - group 7	



## Position switches with swivelling lever without actuator

Contact type:

- R** = snap action
- L** = slow action

Category	Contact block	
2G	5	<b>R</b> FM 538-M2-EX7 Ⓢ 1NO+1NC
M2	20	<b>L</b> FM 2038-M2-EX7 Ⓢ 1NO+2NC
Actuating force	0.06 Nm (0.25 Nm Ⓢ)	
Travel diagrams	page 232 - group 5	

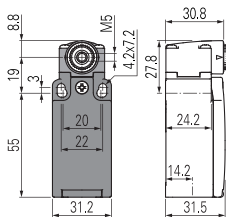

### IMPORTANT

**For safety applications:** join only switches and actuators marked with symbol Ⓢ next to the product code.

For more information about safety applications see details on page 225.

## Separate actuators

**IMPORTANT:** These separate actuators can be used only with items of the FM series.

	Technopolymer roller Ø 18 mm	Technopolymer roller Ø 18 mm	Adjustable square rod, 3x3x125 mm	Adjustable round rod Ø 3x125 mm	Spring rod with plastic tip	Technopolymer roller Ø 20 mm
Article	VN A00KA Ⓢ	VN A00KB Ⓢ	VN A00LB	VN A00LE	VN A00LL	VN A00KE Ⓢ
Max. speed	1.5 m/s (cam at 30°)	1.5 m/s (cam at 30°)	1.5 m/s	1.5 m/s	1.5 m/s	1.5 m/s (cam at 30°)

	Technopolymer roller Ø 20 mm	Porcelain roller	Technopolymer roller Ø 20 mm	Adjustable safety actuator with technopolymer roller	Technopolymer roller Ø 20 mm	Adjustable glass fibre rod
Article	VN A00KF Ⓢ	VN A00LP Ⓢ (2)	VN A00KG Ⓢ	VN A00KP Ⓢ	VN A00KH Ⓢ	VN A00LH
Max. speed	1.5 m/s (cam at 30°)	0,5 ms	1.5 m/s (cam at 30°)	1.5 m/s (cam at 30°)	1.5 m/s (cam at 30°)	1.5 m/s







Steel rollers, Ø 20 mm, with self-lubrication					
VN A00KB-R24 Ⓢ	VN A00KE-R24 Ⓢ	VN A00KF-R24 Ⓢ	VN A00KG-R24 Ⓢ	VN A00KH-R24 Ⓢ	VN A00KP-R24 Ⓢ

**Note:** To order with 316L stainless steel roller: replace R24 with R41 in the order numbers.

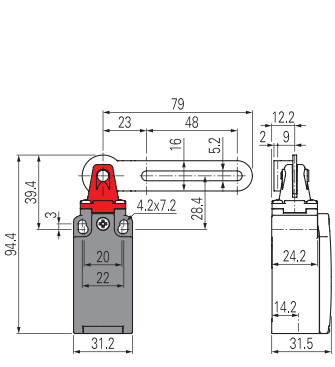
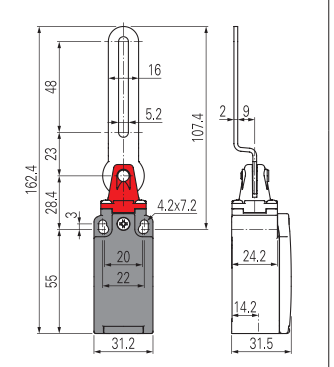
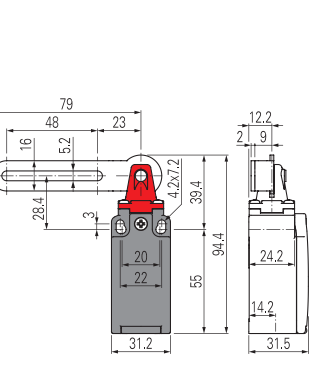
**Note:** To check the correspondence with previous lever codes, please consult the table "Changed article codes" on page 289. Example: VF LE30 -> VN A00KA.

**Safety switches with slotted hole lever**

Contact type:  
 = slow action

Category	Contact block			
		<b>FM 20C1-M2-EX7</b>  1NO+2NC	<b>FM 20C2-M2-EX7</b>  1NO+2NC	<b>FM 20C3-M2-EX7</b>  1NO+2NC
Actuating force		11 N (15 N  )		11 N (15 N  )
Travel diagrams		page 234 - group 10		page 234 - group 10

**Application examples**

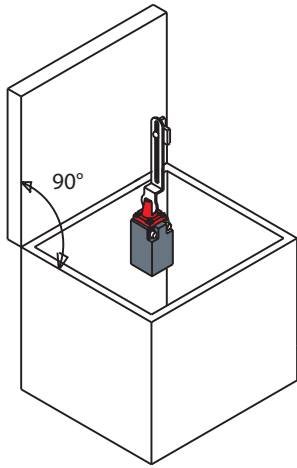

Safety switch with slotted hole lever, mounting inside the safety guard

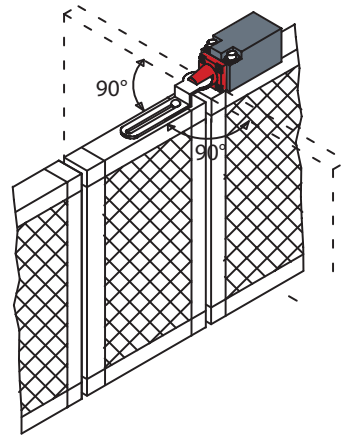



Safety switch with slotted hole lever, mounting on doors with a pivoting range of 180°

**Safety switches for hinges**

**Application examples**

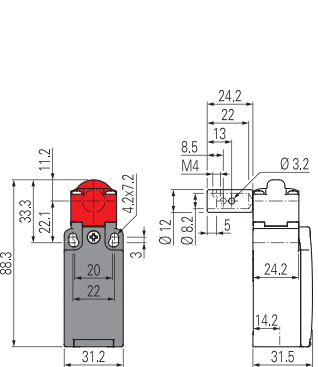
Contact type:  
 = slow action

Category	Contact block	
		<b>FM 2096-M2-EX7</b>  1NO+2NC
Actuating force		0,15 Nm (0,4 Nm  )
Travel diagrams		page 234 - group 9

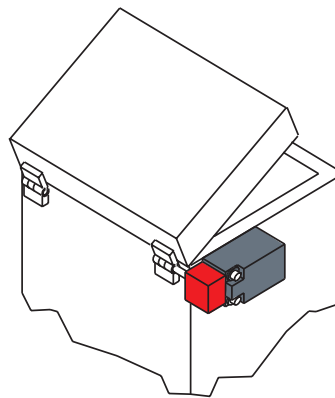

Safety switch for hinges, mounting outside the safety guard

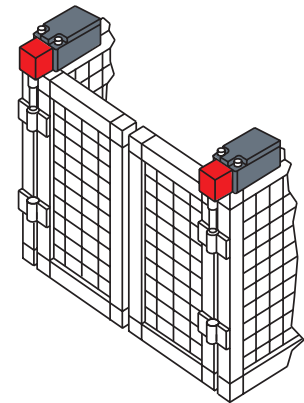

Safety switches for hinges, mounting on double door





### Main features

- ATEX approval
- Metal housing
- Protection degree IP67
- Cable, halogen-free polyurethane

### Technical data

#### Housing

Metal housing, powder-coated  
With cable in halogen-free polyurethane, 2 m, other lengths on request  
Protection degree acc. to EN 60529: IP67

#### General data

Ambient temperature: -20°C ... +60°C  
Max. actuation frequency: 3600 operating cycles/hour  
Mechanical endurance: 10 million operating cycles  
Mounting position: any  
Safety parameters  $B_{10D}$  (NC contacts): 20,000,000  
Mechanical interlock, not coded: type 1 acc. to EN ISO 14119  
Tightening torques for installation: see page 237

#### In compliance with standards:

IEC 60947-5-1, EN 60947-5-1, EN 60947-1, IEC 60204-1, EN 60204-1, EN ISO 14119, EN ISO 12100, IEC 60529, EN 60529, UL 508, CSA C22.2 No. 14, IEC 60079-0, EN 60079-0, IEC 60079-31, EN 60079-31, IEC 60079-15, EN 60079-15, EN IEC 63000.

#### ATEX markings:

Product code extension  
Quality mark

Certificate type and notified body

**-EX5**



EU declaration of conformity  
Pizzato Elettrica S.r.l.

#### Compliance with the requirements of:

ATEX Directive 2014/34/EU, EMC Directive 2014/30/EU, RoHS Directive 2011/65/EU.



#### Positive contact opening in conformity with standards:

IEC 60947-5-1, EN 60947-5-1.

#### Installation for safety applications:

Use only switches marked with the  symbol beside the product code. Always connect the safety circuit to the **NC contacts** (normally closed contacts: see "Internal wiring") as required by **EN ISO 14119, paragraph 5.4** for specific interlock applications and **EN ISO 13849-2 tables D3** (well-tried components) and **D.8** (fault exclusions) for safety applications in general. Actuate the switch **at least up to the positive opening travel** shown in the travel diagrams on page 238. Actuate the switch **at least with the positive opening force**, reported in brackets below each article, next to the actuating force value.

**⚠ If not expressly indicated in this chapter, for correct installation and utilization of all articles see the instructions given in the operating manual and on pages 227 to 242.**

Category	Zone	EPL	Approvals	Utilization category
Product code extension <b>-EX5</b>	3D	22	Dc  II 3D Ex tc IIIC T80°C Dc	Alternating current: AC15 (50±60 Hz) Ue (V) 120 250 400 Ie (A) 6 4 3 Direct current: DC13 Ue (V) 24 125 250 Ie (A) 2.5 0.55 0.27
	3G	2	Gc  II 3G Ex nC IICT6 Gc	
<b>Electrical data</b>				
Thermal current ( $I_{th}$ ):				10 A
Rated insulation voltage ( $U_i$ ):				400 Vac/dc
Conditional short circuit current:				1000 A acc. to EN 60947-5-1
Protection against short circuits:				type aM fuse 10 A 500 V
Pollution degree:				3

### Adjustable levers

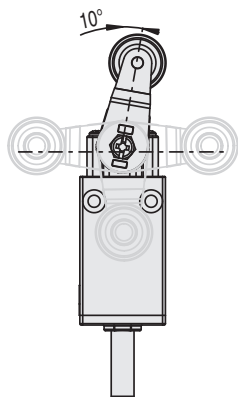

For these switches the lever can be adjusted in 10° steps over the entire 360° range. The positive movement transmission is always guaranteed thanks to the particular geometrical coupling between the lever and the revolving shaft as prescribed for safety applications by the German standard BG-GS-ET-15.

### Reversible levers

With these switches, the lever can be secured in either the normal or reverse position, whereby positive coupling is retained. In this way two different working planes of the lever are possible.

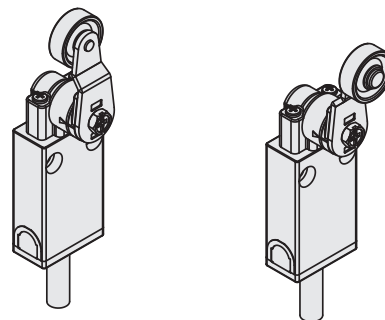

### Internal wiring

1NO+1NC

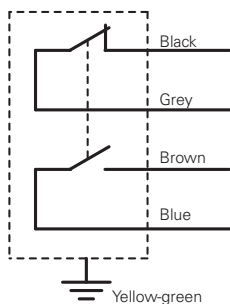

### Head with variable orientation

Depending on the model, it is possible to rotate the head in 90° or 180° steps.

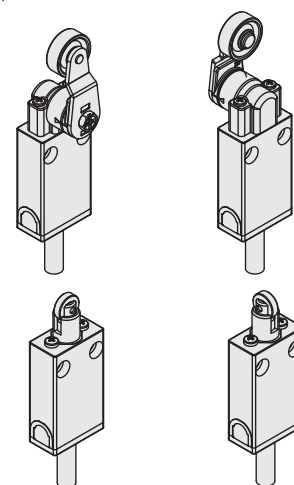











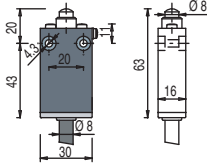
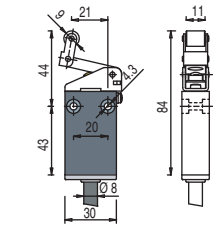
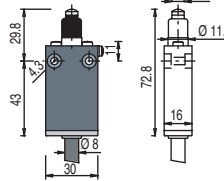
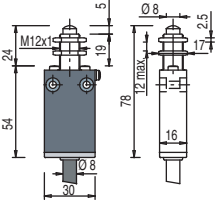





### Code structure











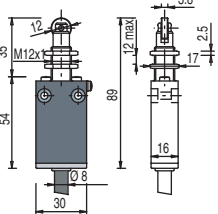
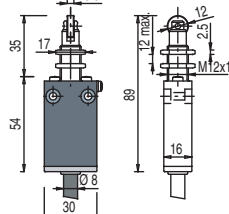
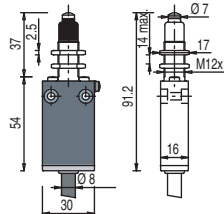
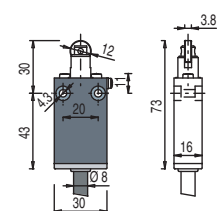





**Attention!** The feasibility of a code number does not mean the effective availability of a product. Please contact our sales office.







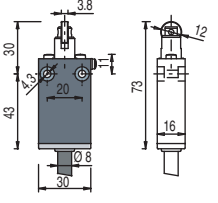
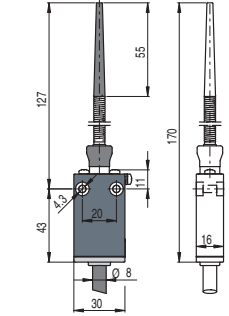
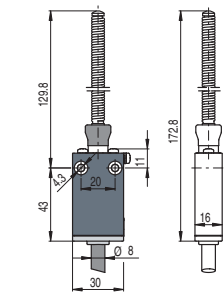
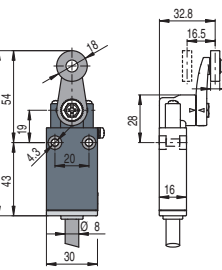

article
options
product code extension  
**FA 4501-2SHG-EX5**

<table border="1" style="width: 100%; border-collapse: collapse;"> <tr><td colspan="2"><b>Housing</b></td></tr> <tr><td><b>FA</b></td><td>metal</td></tr> <tr><td colspan="2"><b>Contact block</b></td></tr> <tr><td><b>45</b></td><td>1NO+1NC, snap action</td></tr> <tr><td><b>46</b></td><td>1NO+1NC, slow action</td></tr> <tr><td colspan="2"><b>Actuators</b></td></tr> <tr><td><b>01</b></td><td>short plunger</td></tr> <tr><td><b>02</b></td><td>unidirectional lever</td></tr> <tr><td><b>08</b></td><td>plunger</td></tr> <tr><td>...</td><td>...</td></tr> <tr><td colspan="2"><b>Connection type</b></td></tr> <tr><td><b>1</b></td><td>cable, length: 1 m</td></tr> <tr><td><b>2</b></td><td>cable length: 2 m</td></tr> <tr><td>...</td><td>...</td></tr> <tr><td><b>0</b></td><td>cable, length: 10 m</td></tr> </table>	<b>Housing</b>		<b>FA</b>	metal	<b>Contact block</b>		<b>45</b>	1NO+1NC, snap action	<b>46</b>	1NO+1NC, slow action	<b>Actuators</b>		<b>01</b>	short plunger	<b>02</b>	unidirectional lever	<b>08</b>	plunger	...	...	<b>Connection type</b>		<b>1</b>	cable, length: 1 m	<b>2</b>	cable length: 2 m	...	...	<b>0</b>	cable, length: 10 m	<table border="1" style="width: 100%; border-collapse: collapse;"> <tr><td colspan="2"><b>ATEX approval</b></td></tr> <tr><td><b>-EX5</b></td><td> <div style="display: flex; gap: 5px;"> <span></span> <span></span> </div> </td></tr> <tr><td colspan="2"><b>Contact type</b></td></tr> <tr><td></td><td>silver contacts (standard)</td></tr> <tr><td><b>G</b></td><td>silver contacts, 1 µm gold coating</td></tr> <tr><td colspan="2"><b>Cable type</b></td></tr> <tr><td><b>H</b></td><td>PUR cable, halogen free</td></tr> <tr><td colspan="2"><b>Output direction</b></td></tr> <tr><td><b>S</b></td><td>bottom output</td></tr> </table>	<b>ATEX approval</b>		<b>-EX5</b>	<div style="display: flex; gap: 5px;"> <span></span> <span></span> </div>	<b>Contact type</b>			silver contacts (standard)	<b>G</b>	silver contacts, 1 µm gold coating	<b>Cable type</b>		<b>H</b>	PUR cable, halogen free	<b>Output direction</b>		<b>S</b>	bottom output
<b>Housing</b>																																																	
<b>FA</b>	metal																																																
<b>Contact block</b>																																																	
<b>45</b>	1NO+1NC, snap action																																																
<b>46</b>	1NO+1NC, slow action																																																
<b>Actuators</b>																																																	
<b>01</b>	short plunger																																																
<b>02</b>	unidirectional lever																																																
<b>08</b>	plunger																																																
...	...																																																
<b>Connection type</b>																																																	
<b>1</b>	cable, length: 1 m																																																
<b>2</b>	cable length: 2 m																																																
...	...																																																
<b>0</b>	cable, length: 10 m																																																
<b>ATEX approval</b>																																																	
<b>-EX5</b>	<div style="display: flex; gap: 5px;"> <span></span> <span></span> </div>																																																
<b>Contact type</b>																																																	
	silver contacts (standard)																																																
<b>G</b>	silver contacts, 1 µm gold coating																																																
<b>Cable type</b>																																																	
<b>H</b>	PUR cable, halogen free																																																
<b>Output direction</b>																																																	
<b>S</b>	bottom output																																																

Other lengths on request.

Contact type: <b>R</b> = snap action <b>L</b> = slow action			Unidirectional operation	External gasket	Secured only by means of threaded head
Category	Contact block				
		FA 4501-2SH-EX5  1NO+1NC	FA 4502-2SH-EX5  1NO+1NC	FA 4508-2SH-EX5  1NO+1NC	FA 4510-2SH-EX5  1NO+1NC
3D	45 <b>R</b>	FA 4501-2SH-EX5  1NO+1NC	FA 4502-2SH-EX5  1NO+1NC	FA 4508-2SH-EX5  1NO+1NC	FA 4510-2SH-EX5  1NO+1NC
3G	46 <b>L</b>	FA 4601-2SH-EX5  1NO+1NC	FA 4602-2SH-EX5  1NO+1NC	FA 4608-2SH-EX5  1NO+1NC	FA 4610-2SH-EX5  1NO+1NC
Max. speed	0.5 m/s		0.5 m/s	0.5 m/s	0.5 m/s
Actuating force	10 N (25 N  )		5 N (25 N  )	10 N (25 N  )	10 N (25 N  )
Travel diagrams	page 238 - group 1		page 238 - group 2	page 238 - group 1	page 238 - group 1

Contact type: <b>R</b> = snap action <b>L</b> = slow action		Secured only by means of threaded head	Secured only by means of threaded head	External gasket	Steel roller, Ø 12 mm, with self-lubrication
Category	Contact block				
		FA 4511-2SH-EX5  1NO+1NC	FA 4512-2SH-EX5  1NO+1NC	FA 4513-2SH-EX5  1NO+1NC	FA 4515-2SH-EX5  1NO+1NC
3D	45 <b>R</b>	FA 4511-2SH-EX5  1NO+1NC	FA 4512-2SH-EX5  1NO+1NC	FA 4513-2SH-EX5  1NO+1NC	FA 4515-2SH-EX5  1NO+1NC
3G	46 <b>L</b>	FA 4611-2SH-EX5  1NO+1NC	FA 4612-2SH-EX5  1NO+1NC	FA 4613-2SH-EX5  1NO+1NC	FA 4615-2SH-EX5  1NO+1NC
Max. speed	0.1 m/s with cam at 30°		0.1 m/s with cam at 30°	0.5 m/s	0.1 m/s with cam at 30°
Actuating force	10 N (25 N  )		10 N (25 N  )	10 N (25 N  )	10 N (25 N  )
Travel diagrams	page 238 - group 1		page 238 - group 1	page 238 - group 1	page 238 - group 1

Contact type: <b>R</b> = snap action <b>L</b> = slow action		Steel roller, Ø 12 mm, with self-lubrication	External gasket	External gasket	With Ø 20 mm steel roller with self-lubrication on request
Category	Contact block				
		FA 4517-2SH-EX5  1NO+1NC	FA 4520-2SH-EX5 1NO+1NC	FA 4525-2SH-EX5 1NO+1NC	FA 4530-2SH-EX5  1NO+1NC
3D	45 <b>R</b>	FA 4517-2SH-EX5  1NO+1NC	FA 4520-2SH-EX5 1NO+1NC	FA 4525-2SH-EX5 1NO+1NC	FA 4530-2SH-EX5  1NO+1NC
3G	46 <b>L</b>	FA 4617-2SH-EX5  1NO+1NC	/	/	FA 4630-2SH-EX5  1NO+1NC
Max. speed	0.1 m/s with cam at 30°		1 m/s	1 m/s	1.5 m/s with cam at 30°
Actuating force	10 N (25 N  )		0.03 Nm	0.06 Nm	0.03 Nm (25 N  )
Travel diagrams	page 238 - group 1		page 238 - group 3	page 238 - group 3	page 238 - group 4



Category		Contact block		With steel roller with self-lubrication on request	Square rod, 3x3 mm	With steel roller with self-lubrication on request	With steel roller with self-lubrication on request			
3D 3G	45	<b>R</b>	FA 4531-2SH-EX5	1NO+1NC	FA 4533-2SH-EX5	1NO+1NC	FA 4534-2SH-EX5	1NO+1NC	FA 4540-2SH-EX5	1NO+1NC
	46	<b>L</b>	FA 4631-2SH-EX5	1NO+1NC	FA 4633-2SH-EX5	1NO+1NC	FA 4634-2SH-EX5	1NO+1NC	FA 4640-2SH-EX5	1NO+1NC
Max. speed		1.5 m/s with cam at 30°		1.5 m/s		1.5 m/s		1.5 m/s with cam at 30°		
Actuating force		0.03 Nm (0.25 Nm $\rightarrow$ )		0.03 Nm		0.03 Nm		0.03 Nm (0.25 Nm $\rightarrow$ )		
Travel diagrams		page 238 - group 4		page 238 - group 4		page 238 - group 4		page 238 - group 4		

Category		Contact block		Stainless steel round rod, $\varnothing$ 3 mm, with self-lubrication	With steel roller with self-lubrication on request	With steel roller with self-lubrication on request	With steel roller with self-lubrication on request			
3D 3G	45	<b>R</b>	FA 4550-2SH-EX5	1NO+1NC	FA 4551-2SH-EX5	1NO+1NC	FA 4552-2SH-EX5	1NO+1NC	FA 4554-2SH-EX5	1NO+1NC
	46	<b>L</b>	FA 4650-2SH-EX5	1NO+1NC	FA 4651-2SH-EX5	1NO+1NC	FA 4652-2SH-EX5	1NO+1NC	FA 4654-2SH-EX5	1NO+1NC
Max. speed		1.5 m/s		1.5 m/s with cam at 30°		1.5 m/s with cam at 30°		1.5 m/s with cam at 30°		
Actuating force		0.03 Nm		0.03 Nm (0.25 Nm $\rightarrow$ )		0.03 Nm (0.25 Nm $\rightarrow$ )		0.03 Nm (0.25 Nm $\rightarrow$ )		
Travel diagrams		page 238 - group 4		page 238 - group 4		page 238 - group 4		page 238 - group 4		

Category		Contact block		With steel roller with self-lubrication on request	With steel roller with self-lubrication on request	With steel roller with self-lubrication on request	Glass fibre rod		
3D 3G	45	<b>R</b>	FA 4555-2SH-EX5	1NO+1NC	FA 4556-2SH-EX5	1NO+1NC	FA 4569-2SH-EX5	1NO+1NC	
	46	<b>L</b>	FA 4655-2SH-EX5	1NO+1NC	FA 4656-2SH-EX5	1NO+1NC	FA 4669-2SH-EX5	1NO+1NC	
Max. speed		1.5 m/s with cam at 30°		1.5 m/s with cam at 30°		1.5 m/s with cam at 30°		1.5 m/s	
Actuating force		0.03 Nm (0.25 Nm $\rightarrow$ )		0.03 Nm (0.25 Nm $\rightarrow$ )		0.03 Nm (0.25 Nm $\rightarrow$ )		0.03 Nm	
Travel diagrams		page 238 - group 4		page 238 - group 4		page 238 - group 4		page 238 - group 4	

<sup>(1)</sup> Positive opening only with actuator set to max.

## Accessories

## ATEX cable gland, technopolymer

**Technical data:**

ATEX marking:

 II 2G Ex eb IIC Gb II 1D Ex ta IIIC Da

Body and ring material:

Plastic PA V0 acc. to UL 94

Ambient temperature:

-20°C ... +85°C

Protection degree:

IP68 (≤ 10 bar)

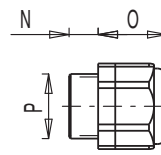
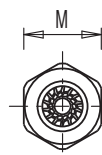

Article	Description	ATEX certificate number	 M	N	O	P
VF PBM20C6P-2GD	M20x1.5 technopolymer cable gland for multipolar cables Ø 6.5 ... 12 mm	IECEX BVS 14.0020X BVS 14 ATEX E 025 X	24	9	24	M20x1.5

## ATEX cable gland, metal

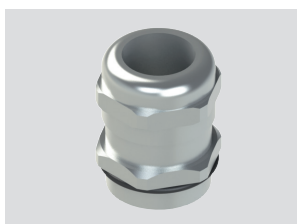
**Technical data:**

ATEX marking:

 II 2G Ex e II II 1D Ex tD A20 IP68

Body and ring material:

Nickel-plated brass

Ambient temperature:

-20°C ... +95°C

Protection degree:

IP68 (≤ 10 bar)

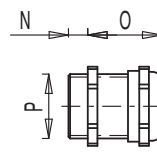

Article	Description	ATEX certificate number	 M	N	O	P
VF PBM20C6M-2GD	M20x1.5 brass cable gland for multipolar cables Ø 6 ... 12 mm	KEMA 99ATEX6971 X	24	9	24	M20x1.5





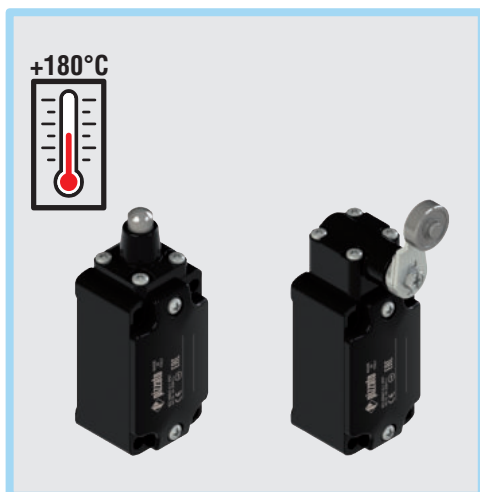

#### Main features

- Operating temperature up to +180°C
- Metal housing, one conduit entry
- Protection degree IP67

#### Quality marks:



EAC approval: RU C-IT.YT03.B.00035/19

#### Technical data

##### Housing

Metal housing, powder-coated  
One threaded conduit entry:  
Protection degree acc. to EN 60529:

M20 x 1.5  
IP67 with cable gland of equal or  
higher protection degree

##### General data

Ambient temperature: -15°C ... +180°C for FD 2011-M2T2 and  
FD 2016-M2T2 articles  
-25°C ... +180°C for all other articles

Max. actuation frequency: 3600 operating cycles/hour

Mechanical endurance: 1 million operating cycles

Mounting position: any

Safety parameter  $B_{10D}$ : 2,000,000 for NC contacts

Mechanical interlock, not coded: type 1 acc. to EN ISO 14119

Fixing screws for the housing: M5 with spring washer

Tightening torques for installation: see page 229

Wire cross-sections and  
wire stripping lengths: see page 249

##### In compliance with standards:

IEC 60947-5-1, EN 60947-5-1, EN 60947-1, EN 50041, IEC 60204-1, EN 60204-1,  
EN ISO 14119, EN ISO 12100, IEC 60529, EN 60529, EN IEC 63000, UL 508,  
CSA C22.2 No. 14.

##### Compliance with the requirements of:

Low Voltage Directive 2014/35/EU, EMC Directive 2014/30/EU,  
RoHS Directive 2011/65/EU.

##### Positive contact opening in conformity with standards:

IEC 60947-5-1, EN 60947-5-1.

#### Installation for safety applications:

Use only switches marked with the  $\ominus$  symbol beside the product code. Always connect the safety circuit to the **NC contacts** (normally closed contacts: 11-12, 21-22 or 31-32) as required by **EN ISO 14119, paragraph 5.4** for specific interlock applications and **EN ISO 13849-2 tables D3** (well-tried components) and **D.8** (fault exclusions) for safety applications in general. Actuate the switch **at least up to the positive opening travel** shown in the travel diagrams on page 230. Actuate the switch **at least with the positive opening force**, reported in brackets below each article, next to the actuating force value.

**⚠ If not expressly indicated in this chapter, for correct installation and utilization of all articles see the instructions given on pages 227 to 242.**

#### Electrical data

#### Utilization category

Ambient temperature +20 °C	Thermal current ( $I_{th}$ ):	4 A	Alternating current: AC15 (50÷60 Hz)			
	Rated insulation voltage ( $U_i$ ):	250 Vac 300 Vdc	Ue (V)	24	120	250
	Rated impulse withstand voltage ( $U_{imp}$ ):	4 kV	Ie (A)	4	4	4
	Conditional short circuit current:	1000 A acc. to EN 60947-5-1	Direct current: DC13			
	Protection against short circuits:	type gG fuse 4 A 250 V	Ue (V)	24	125	250
	Pollution degree:	3	Ie (A)	3	0.55	0.3

Ambient temperature +180 °C	Thermal current ( $I_{th}$ ):	4 A	Alternating current: AC15 (50÷60 Hz)			
	Rated insulation voltage ( $U_i$ ):	250 Vac 300 Vdc	Ue (V)	24	120	250
	Protection against short circuits:	type gG fuse 4 A 250 V	Ie (A)	4	4	4
	Pollution degree:	3	Direct current: DC13			
			Ue (V)	24		
			Ie (A)	1		

### Adjustable levers

For switches with swivelling lever, the lever can be adjusted in 10° steps over the entire 360° range. The positive movement transmission is always guaranteed thanks to the particular geometrical coupling between the lever and the revolving shaft as prescribed for safety applications by the German standard BG-GS-ET-15.

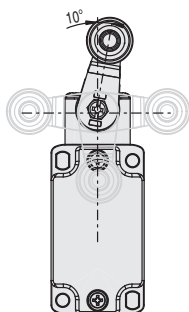

### Reversible levers

For switches with swivelling lever, the lever can be fastened on straight or reverse side maintaining the positive coupling. In this way two different working planes of the lever are possible.

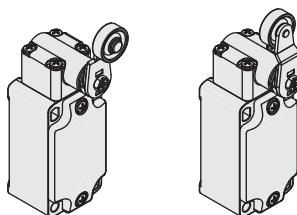

### Head with variable orientation

For all switches the head can be rotated in 90° steps.

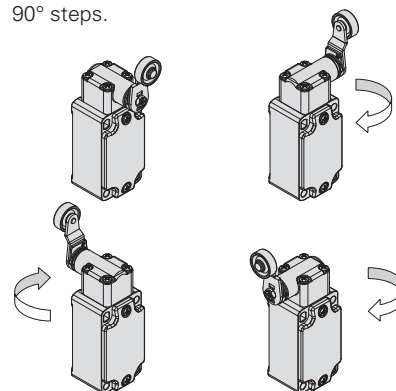

### Dimensional drawings

Contact type  
**L** = slow action

Contact block	20 <b>L</b>	FD 2011-M2T2	FD 2016-M2T2	FD 2031-M2R24T2	FD 2032-M2T2
Max. speed		page 229 - type 4	page 229 - type 2	page 229 - type 1	1.5 m/s
Actuating force		8 N (25 N	8 N (25 N	0.1 Nm (0.25 Nm	0.1 Nm
Travel diagrams		page 230 - group 1	page 230 - group 1	page 230 - group 4	page 230 - group 4

Contact type  
**L** = slow action

Contact block	20 <b>L</b>	FD 2033-M2T2	FD 2056-M2R24T2	FD 2057-M2R24T2	FD 2038-M2T2
Max. speed		1.5 m/s	page 229 - type 1	page 229 - type 1	/
Actuating force		0.1 Nm	0.1 Nm (0.25 Nm	0.1 Nm (0.25 Nm	0.1 Nm (0.25 Nm
Travel diagrams		page 230 - group 4	page 230 - group 4	page 230 - group 4	page 230 - group 4

### Special separate actuators for high temperatures

Steel roller with self-lubrication, Ø 20 mm	Adjustable round rod Ø 3x125 mm	Adjustable square rod, 3x3x125 mm	Steel roller with self-lubrication, Ø 20 mm	Steel roller with self-lubrication, Ø 20 mm	Adjustable actuator with steel roller with self-lubrication, Ø 20 mm	Steel roller with self-lubrication, Ø 20 mm
VF L31-R24T2	VF L32-T2	VF L33-T2	VF L51-R24T2	VF L52-R24T2	VF L56-R24T2	VF L57-R24T2

**Note:** To order with 316L stainless steel roller: replace R24 with R41 in the order numbers.

**IMPORTANT: For safety applications:** join only switches and actuators marked with symbol next to the product code.

All values in the drawings are in mm

**Accessories** See page 207

→ The 2D and 3D files are available at [www.pizzato.com](http://www.pizzato.com)

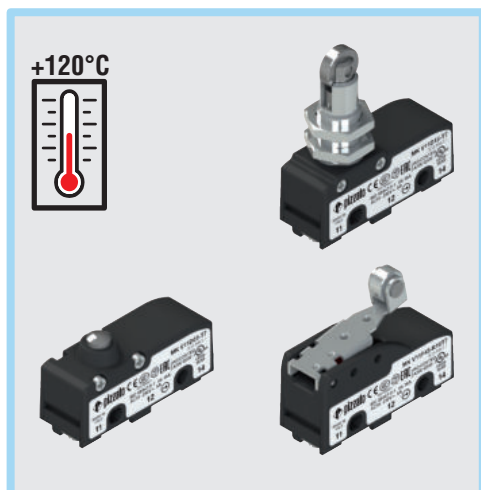

### Main features

- Operating temperature up to +120°C
- Technopolymer housing
- High reliability contacts
- 4 terminal types available
- 15 actuators available
- Versions with positive opening ⊕
- Versions with gold-plated silver contacts

### Quality marks:



IMQ approval: CA02.05772  
 UL approval: E131787  
 EAC approval: RU C-IT.YT03.B.00035/19

### Technical data

#### Housing

Housing made of glass fibre reinforced technopolymer, self-extinguishing and shock-proof.  
 Protection degree acc. to EN 60529: IP00 (terminals)  
 IP40 (electrical contacts)

#### General data

Ambient temperature: -25°C ... +120°C  
 Max. actuation frequency: 3600 operating cycles/hour  
 Mechanical endurance: 500,000 operating cycles  
 Safety parameter  $B_{10D}$ : 1,000,000 for NC contacts  
 Tightening torques for installation: see page 190

#### Cable cross section (flexible copper strands)

MK series: min. 1 x 0.34 mm<sup>2</sup> (1 x AWG 22)  
 max. 2 x 1.5 mm<sup>2</sup> (2 x AWG 16)

#### Cable stripping length (x):

MK V••••• articles (screw connection): 7 mm

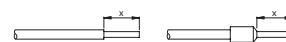

#### In compliance with standards:

IEC 60947-5-1, EN 60947-5-1, IEC 60529, EN 60529, EN 60947-1, EN IEC 63000, IEC 60947-1.

#### Compliance with the requirements of:

Low Voltage Directive 2014/35/EU, EMC Directive 2014/30/EU, RoHS Directive 2011/65/EU.

#### Positive contact opening in conformity with standards:

IEC 60947-5-1, EN 60947-5-1.

#### Installation for safety applications:

Use only microswitches marked with the ⊕ symbol beside the product code. Always connect the safety circuit to the **NC contacts** (normally closed contacts) as required by **EN ISO 14119, paragraph 5.4** for specific interlock applications and **EN ISO 13849-2 tables D3** (well-tried components) and **D.8** (fault exclusions) for safety applications in general. Actuate the switch **at least up to the positive opening travel (CAP)** reported next to the article code. Actuate the switch **at least with the positive opening force (FAP)** reported next to the article code.

⚠ **If not expressly indicated in this chapter, for correct installation and utilization of all articles see the instructions given on pages 227 to 242.**

### Electrical data

### Utilization category

Ambient temperature +20 °C			Utilization category			
Ambient temperature +20 °C	Thermal current ( $I_{th}$ ):	16 A	Alternating current: AC15 (50 ... 60 Hz)			
	Rated insulation voltage ( $U_i$ ):	250 Vac 300 Vdc	$U_e$ (V)	120	250	
	Rated impulse withstand voltage ( $U_{imp}$ ):	4 kV	$I_e$ (A)	3	5	
	Conditional short circuit current:	1000 A acc. to EN 60947-5-1	Direct current: DC13			
	Protection against short circuits:	type gG fuse 16 A 250 V	$U_e$ (V)	24	125	250
	Pollution degree:	3	$I_e$ (A)	4	0.6	0.3
	Dielectric strength	2000 Vac/min.				
Ambient temperature +120 °C	Thermal current ( $I_{th}$ ):	3 A	Alternating current: AC15 (50 ... 60 Hz)			
	Rated insulation voltage ( $U_i$ ):	250 Vac 300 Vdc	$U_e$ (V)	120	250	
	Rated impulse withstand voltage ( $U_{imp}$ ):	4 kV	$I_e$ (A)	3	2	
	Conditional short circuit current:	1000 A acc. to EN 60947-5-1	Direct current: DC13			
	Protection against short circuits:	Fuse - 3 A or less 250 V type gG	$U_e$ (V)	24	125	
	Pollution degree:	3	$I_e$ (A)	2	0.5	
	Dielectric strength	2000 Vac/min.				

### Features approved by IMQ

Rated insulation voltage ( $U_i$ ): 250 Vac  
 Conventional free air thermal current ( $I_{th}$ ): 3 A  
 Protection against short circuits: type gG fuse 3 A 250 V  
 Rated impulse withstand voltage ( $U_{imp}$ ): 4 kV  
 Conditional short circuit current: 1000 A  
 MF, MS terminals  
 Pollution degree: 3  
 Utilization category: AC15  
 Operating voltage ( $U_e$ ): 250 Vac (50 Hz)  
 Operating current ( $I_e$ ): 5 A  
 Forms of the contact element: C

In compliance with standards: EN 60947-1, EN 60947-5-1, fundamental requirements of the Low Voltage Directive 2014/35/EU.

Please contact our technical department for the list of approved products.



## Terminal dimensions

All values in the drawings are in mm

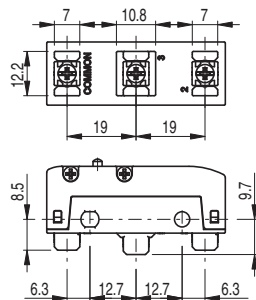

Screw terminals **V** with plate

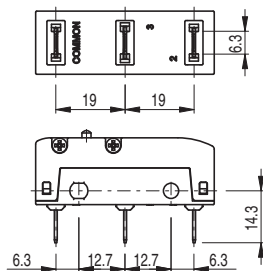

Faston terminals **H**, vertical

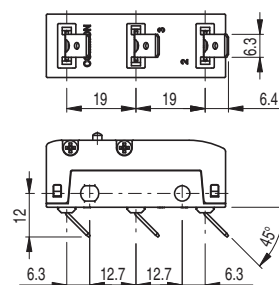

Faston terminals **F**, right angle

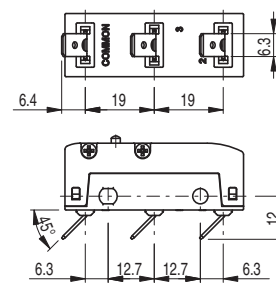

Faston terminals **G**, left angle (upon request)

**Note:** The vertical faston terminals H can be bent according to specific installation requirements.

We recommend to bend the faston with an angle not higher than 45° and to carry out this operation no more than 5 times.

## Circuit diagram

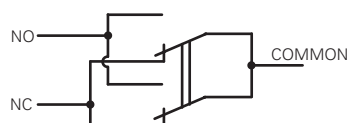

Mobile contact with single interruption and double contacts

With direct actuation and direct actuation at the back (F, D)

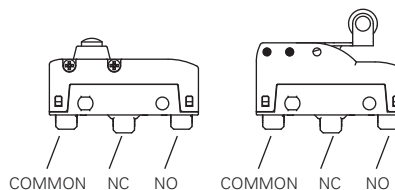

## Actuation forces and travels

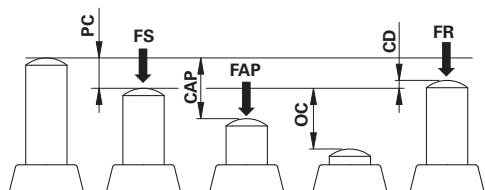

**PC** pre-travel

**CAP** positive opening travel

**OC** over-travel

**CD** differential travel

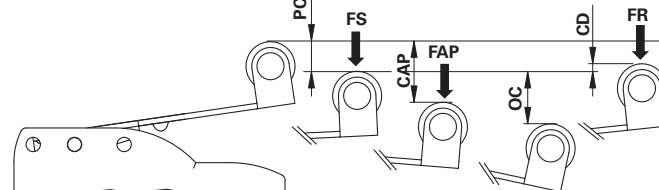

**FS** Trigger force

**FR** release force

**FAP** positive opening force

## Code structure

**Attention!** The feasibility of a code number does not mean the effective availability of a product. Please contact our sales office.

article options  
**MK V11F45-GR16T7**

### Terminal type

**V** screw with self-lifting plate

**H** vertical faston

**F** Faston, 45° bend to the right

**G** Faston, 45° bend to the left (on request)

### Ambient temperature

**T7** -25°C ... +120°C

### Rollers

**R16** metal roller Ø 9.5x4 mm (for actuators 40, 42, 45, 59 only)

### Contact block

**1** 1NO+1NC, snap action, change-over

### Contact type

silver contacts (standard)

**G** silver contacts, 1 µm gold coating

### Actuator

**05** low plunger

**06** threaded plunger

**08** threaded plunger

... ..

### Type of actuation

**D** direct actuation

**F** direct actuation at the back

## MK series microswitches for high temperatures

<b>MK V11D05-T7</b> 1NO+1NC PC 0.5 mm FS 4 N OC 2 mm FR 3 N CD 0.05 mm FAP 20 N CAP 2.2 mm	<b>MK V11D06-T7</b> 1NO+1NC PC 0.5 mm FS 4 N OC 3 mm FR 3 N CD 0.05 mm FAP 20 N CAP 2.2 mm
Maximum and minimum speed see page 239 - type 1	
<b>MK V11D08-T7</b> 1NO+1NC PC 0.5 mm FS 4 N OC 5.5 mm FR 3 N CD 0.05 mm FAP 20 N CAP 2.2 mm	<b>MK V11D09-T7</b> 1NO+1NC PC 0.5 mm FS 4 N OC 5.5 mm FR 3 N CD 0.05 mm FAP 20 N CAP 2.2 mm
Maximum and minimum speed see page 239 - type 1	
<b>MK V11D10-T7</b> 1NO+1NC PC 0.5 mm FS 4 N OC 5.5 mm FR 3 N CD 0.05 mm FAP 20 N CAP 2.2 mm	<b>MK V11D12-T7</b> 1NO+1NC PC 0.5 mm FS 4 N OC 5.5 mm FR 3 N CD 0.05 mm FAP 20 N CAP 2.2 mm
Maximum and minimum speed see page 239 - type 1	
<p style="text-align: center;">Mounting only through threaded fitting</p>	<p style="text-align: center;">Mounting only through threaded fitting</p>
<b>MK V11D15-T7</b> 1NO+1NC PC 0.5 mm FS 4 N OC 5.5 mm FR 3 N CD 0.05 mm FAP 20 N CAP 2.2 mm	<b>MK V11D17-T7</b> 1NO+1NC PC 0.5 mm FS 4 N OC 5.5 mm FR 3 N CD 0.05 mm FAP 20 N CAP 2.2 mm
Maximum and minimum speed see page 239 - type 2	
<b>MK V11F30-T7</b> 1NO+1NC PC 3.2 mm FS 0.6 N OC 11.2 mm FR 0.5 N CD 0.35 mm	<b>MK V11F31-T7</b> 1NO+1NC PC 1.45 mm FS 1.5 N OC 5 mm FR 0.92 N CD 0.17 mm FAP 5.78 N CAP 5.72 mm
Maximum and minimum speed see page 239 - type 5	



	<b>MK V11F32-T7</b> 1NO+1NC PC 2.7 mm FS 0.7 N OC 9.3 mm FR 0.6 N CD 0.4 mm		<b>MK V11F40-R16T7</b> 1NO+1NC PC 2.1 mm FS 0.85 N OC 8.3 mm FR 0.65 N CD 0.25 mm
Maximum and minimum speed see page 239 - type 5		Maximum and minimum speed see page 239 - type 8	
	<b>MK V11F42-R16T7</b> 1NO+1NC PC 1.8 mm FS 1 N OC 6.7 mm FR 0.7 N CD 0.2 mm FAP 4.9 N CAP 9 mm		<b>MK V11F45-R16T7</b> 1NO+1NC PC 1.1 mm FS 1.3 N OC 4.9 mm FR 0.9 N CD 0.1 mm FAP 6.9 N CAP 6.3 mm
Maximum and minimum speed see page 239 - type 8		Maximum and minimum speed see page 239 - type 8	
	<b>MK V11F59-R16T7</b> 1NO+1NC PC 0.8 mm FS 1.7 N OC 4.5 mm FR 1.3 N CD 0.08 mm FAP 8.9 N CAP 4.9 mm		
Maximum and minimum speed see page 239 - type 8		All values in the drawings are in mm	

## Tightening torques

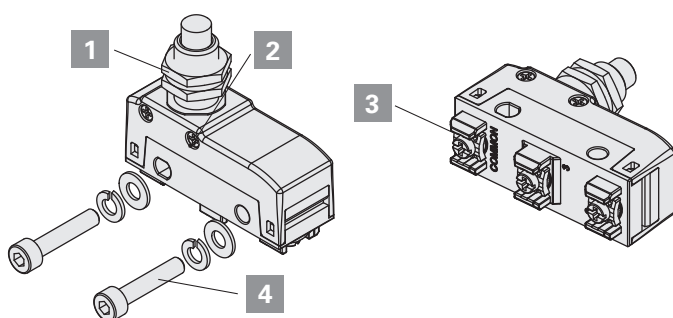

- |  |                       |
|--|-----------------------|
| 1 Head nuts  | <b>2 ... 3 Nm</b>     |
| 2 Head screws  | <b>0.3 ... 0.4 Nm</b> |
| 3 Terminal screws  | <b>0.6 ... 0.8 Nm</b> |
| 4 M4 fixing screws, body (insert a washer and a spring washer) | <b>0.8 ... 1.2 Nm</b> |
- Attention:** a tightening torque higher than 1.2 Nm can cause the breaking of the microswitch.

## Accessories

Packs of **10 pcs.**

Article <b>VF AC83</b>	Description Hex threaded nut for microswitches with actuators D06, D08, D09

Article <b>VF AC72</b>	Description Hex threaded nut for microswitches with actuators D10, D12, D13

Article <b>AC 35</b>	Description Hex threaded nut, notched, for microswitches with actuators D15, D16

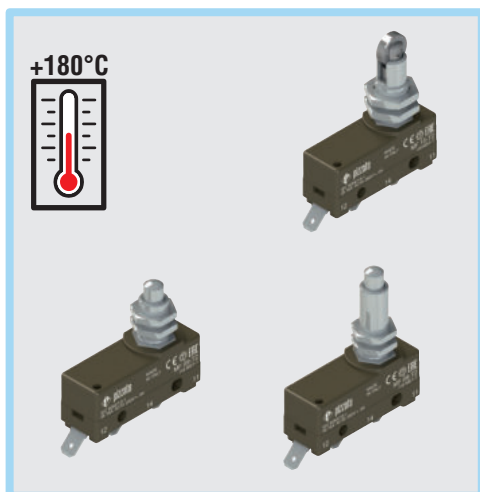

### Main features

- Operating temperature up to +180°C
- Technopolymer housing
- Protection degree IP20 or IP40
- 2 terminal types available
- 5 actuators available

### Quality marks:



IMQ approval: CA02.05772  
EAC approval: RU C-IT.YT03.B.00035/19

**⚠ If not expressly indicated in this chapter, for correct installation and utilization of all articles see the instructions given on pages 227 to 242.**

## Technical data

### Housing

Housing made of glass fibre reinforced technopolymer, self-extinguishing and shock-proof.  
Protection degree acc. to EN 60529: IP00 (terminals)  
IP40 (electrical contacts)

### General data

Ambient temperature: -25°C ... +180°C  
Max. operating frequency: 3600 operating cycles/hour  
Mechanical endurance: 1 million operating cycles  
Tightening torques for installation: see page 194

### In compliance with standards:

IEC 60947-5-1, EN 60947-5-1, IEC 60528, EN 60529, EN IEC 63000.

### Approvals:

EN 60947-5-1

### Compliance with the requirements of:

Low Voltage Directive 2014/35/EU,  
EMC Directive 2014/30/EU,  
RoHS Directive 2011/65/EU.

### Electrical data

Ambient temperature +20 °C	Thermal current ( $I_{th}$ ):	16 A
	Rated insulation voltage ( $U_i$ ):	250 Vac 300 Vdc
	Rated impulse withstand voltage $U_{imp}$ :	4 kV
	Conditional short circuit current:	1000 A acc. to EN 60947-5-1
	Protection against short circuits:	type gG fuse 16 A 250 V
	Pollution degree:	3
	Dielectric strength:	2000 V~ between terminals and other metal parts to ground.

### Utilization category

Alternating current: AC15 (50÷60 Hz)			
$U_e$ (V)	250		
$I_e$ (A)	5		
Direct current: DC13			
$U_e$ (V)	24	125	250
$I_e$ (A)	5	0.5	0.3

Ambient temperature +180 °C	Thermal current ( $I_{th}$ ):	12 A
	Rated insulation voltage ( $U_i$ ):	250 Vac 300 Vdc
	Rated impulse withstand voltage $U_{imp}$ :	4 kV
	Conditional short circuit current:	1000 A acc. to EN 60947-5-1
	Protection against short circuits:	type gG fuse 12 A 250 V
	Pollution degree:	3
	Dielectric strength:	2000 V~ between terminals and other metal parts to ground.

Alternating current: AC15 (50÷60 Hz)			
$U_e$ (V)	250		
$I_e$ (A)	5		
Direct current: DC13			
$U_e$ (V)	24		
$I_e$ (A)	3		

### Features approved by IMQ

Rated insulation voltage ( $U_i$ ):	250 Vac
Conventional free air thermal current ( $I_{th}$ ):	12 A
Protection against short circuits:	type gG fuse 12 A 250 V
Rated impulse withstand voltage ( $U_{imp}$ ):	4 kV
Conditional short circuit current:	1000 A
MF, MS terminals	
Pollution degree:	3
Utilization category:	AC15
Operating voltage ( $U_e$ ):	250 Vac (50 Hz)
Operating current ( $I_e$ ):	5 A
Forms of the contact element: C	

In compliance with standards: EN 60947-1, EN 60947-5-1, fundamental requirements of the Low Voltage Directive 2014/35/EU.

Please contact our technical department for the list of approved products.



## Terminal dimensions

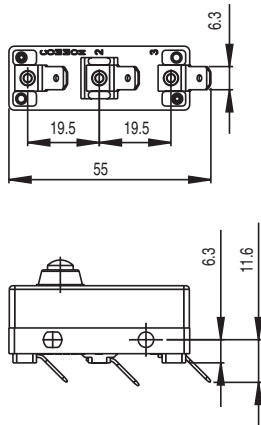

All values in the drawings are in mm

## Circuit diagram

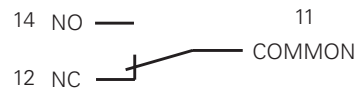
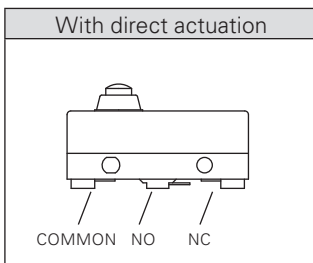

Change-over contact element with single interruption and three terminals.

## Actuation forces and travels

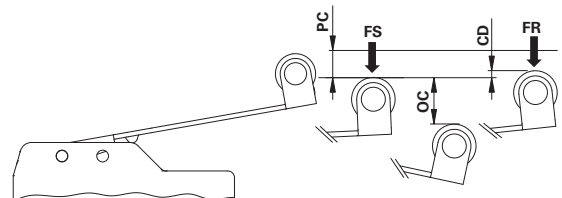
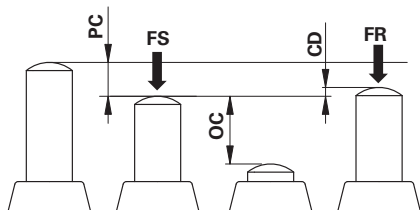

- PC** pre-travel
- OC** over-travel
- CD** differential travel
- FS** Trigger force
- FR** release force

## Code structure

**Attention!** The feasibility of a code number does not mean the effective availability of a product. Please contact our sales office.

article  
**MF 08-T2**

Terminal type  
**MF** faston terminals

Ambient temperature  
**T2** -25°C ... +180°C

Actuator

- 08** threaded plunger M10 x 0.75
- 09** threaded plunger M10 x 0.75
- 10** threaded plunger M12 x 1
- 15** threaded plunger with roller
- 17** threaded plunger with transversal roller

## Microswitches with direct actuation

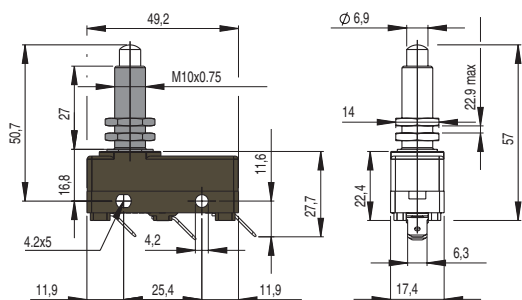

MF 08-T2	PC	0.5 mm	FS	3.9 N
	OC	5.5 mm	FR	2.7 N
	CD	0.05 mm		

Maximum and minimum speed see page 240 - type 1

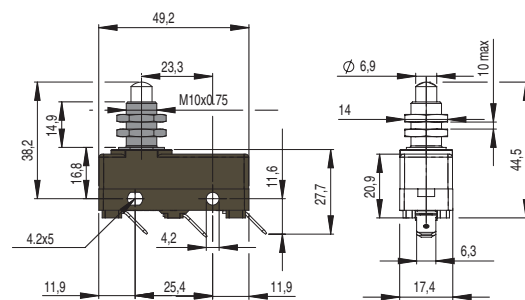

MF 09-T2	PC	0.5 mm	FS	3.9 N
	OC	5.5 mm	FR	2.7 N
	CD	0.05 mm		

Maximum and minimum speed see page 240 - type 1

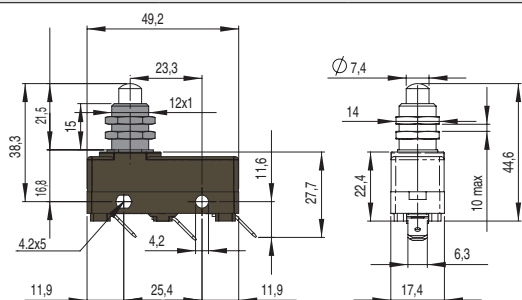

MF 10-T2	PC	0.5 mm	FS	3.9 N
	OC	5.5 mm	FR	2.7 N
	CD	0.05 mm		

Maximum and minimum speed see page 240 - type 1

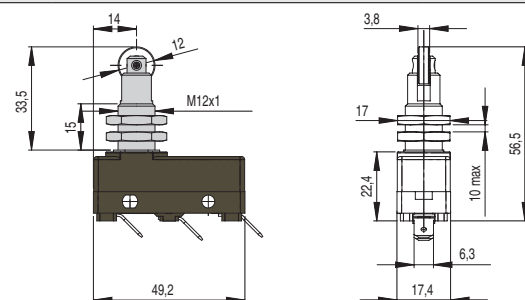

Secured only by means of threaded head

MF 15-T2	PC	0.5 mm	FS	3.9 N
	OC	5.5 mm	FR	2.7 N
	CD	0.05 mm		

Maximum and minimum speed see page 240 - type 2

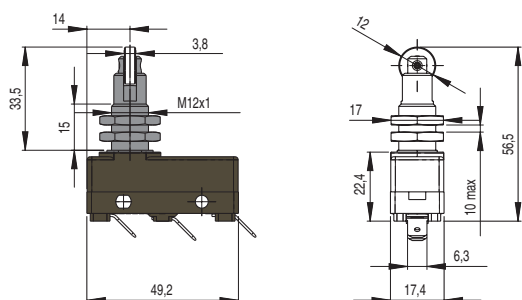

Secured only by means of threaded head

MF 17-T2	PC	0.5 mm	FS	3.9 N
	OC	5.5 mm	FR	2.7 N
	CD	0.05 mm		

Maximum and minimum speed see page 240 - type 2

## Tightening torques

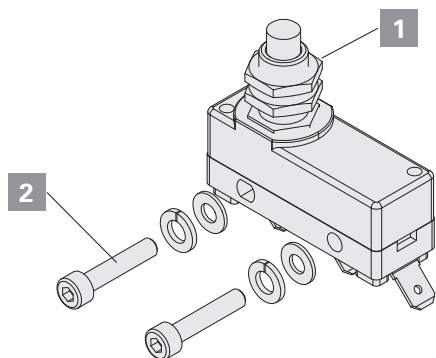

**1** Head nuts

**2 ... 3 Nm**

**2** M4 fixing screws, body (insert a washer and a spring washer)

**0.8 ... 1.2 Nm**

**Attention:** a tightening torque higher than 1.2 Nm can cause the breaking of the microswitch.

## Accessories Packs of 10 pcs.

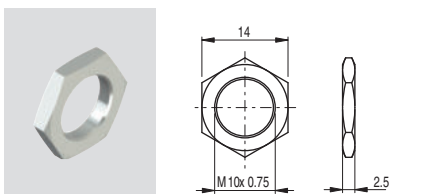

Article	Description
VF AC83	Hex threaded nut for microswitches with actuators 08, 09

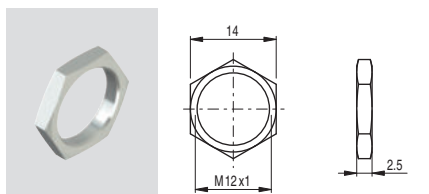

Article	Description
VF AC72	Hex threaded nut for microswitches with actuator 10

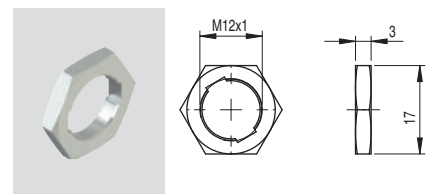

Article	Description
AC 35	Hex threaded nut, notched, for microswitches with actuators 15, 17

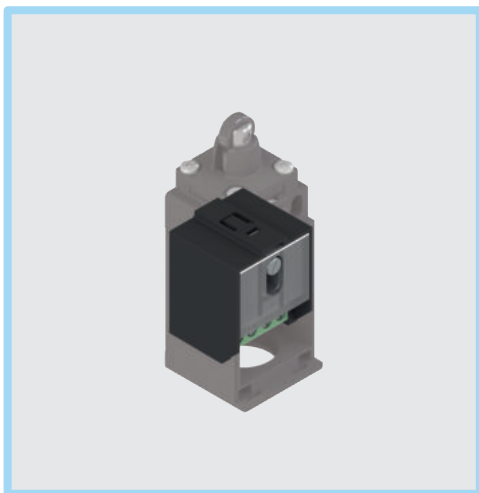

#### Main features

- Adjustable switching point
- Bounce-free output signals
- Two static outputs, 1NO and 1NC
- Reduced actuating force
- Signal LEDs for power supply and switching
- Minimum differential travel

#### Quality marks:



EAC approval: RU C-IT.YT03.B.00035/19

#### Description

E1 is an electronic contact block, designed to replace the traditional mechanical contact block installed inside Pizzato Elettrica's position switches. The combination provided by the union of the mechanical body and sensor head of the position switches and this electronic contact block forms a mechatronics device that increases the application range of position switches.

#### General data

Ambient temperature:	-25°C ... +80°C
Max. actuation frequency:	3600 operating cycles/hour
Mechanical endurance:	20 million operating cycles
Adjustable operating distance:	0.2 ... 2 mm or 2° ... 30°
Differential travel:	< 0.1 mm or < 1°
Tightening torque of the terminal screws:	0.6 ... 0.8 Nm
Wire cross-sections and wire stripping lengths:	see page 249

#### Electrical data

Rated operating voltage (Ue):	10 ... 30 Vdc
Rated operating current (Ie):	200 mA
Utilization category:	DC13, 24V 0,2A
Rated insulation voltage (Ui):	30 V
Pollution degree:	3
Conditional short circuit current:	100 A
Voltage drop (Ud):	2 V
Minimum operating current (Im):	0 mA
Current in locked state (Ir):	0.05 mA
Maximum residual ripple:	10%
Current consumption w/o load (Io):	< 10 mA
Short-circuit protection:	yes
Reverse-polarity protection:	yes
Output type:	PNP
LED, power supply:	yes
LED, switching:	yes
Protection fuse:	315 mA, fast

#### In compliance with standards:

IEC 60947-5-1, EN 60947-5-1, IEC 60529, EN 60529, EN IEC 63000.

#### Compliance with the requirements of:

Low Voltage Directive 2014/35/EU, EMC Directive 2014/30/EU, RoHS Directive 2011/65/EU.

**⚠ If not expressly indicated in this chapter, for correct installation and utilization of all articles see the instructions given on pages 227 to 242.**

#### Parallel connection of several units E1 (OR)

For connecting the switches in parallel (OR) no particular protective measures are required. We recommend the installation of a commercially available diode for use with inductive loads (relays).

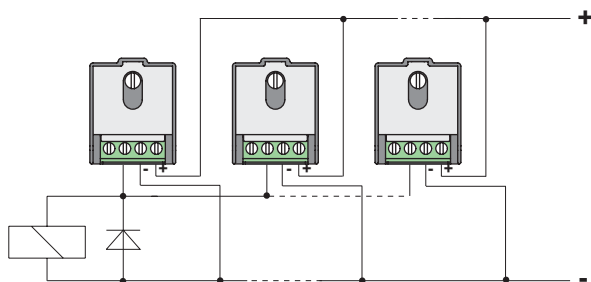

#### Wiring diagram

The wires are connected via a terminal strip where the function of the individual poles is marked by silk screen printing. Furthermore there are two signal LEDs, one for power supply and one for switching state.

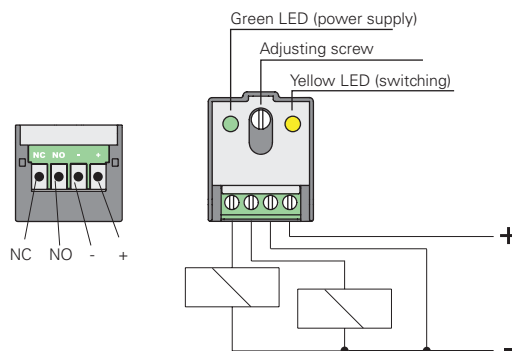

## Main features

The E1 contact block consists of an optical detection system for the position of the mechanical actuator with the following features:

- 1) possibility of adjusting the switching point by means of a screw, directly on the contact block;
- 2) differential travel below 0.1 mm, guaranteed over the entire operating temperature range;
- 3) reduced actuating force;
- 4) two static outputs, 1NO + 1NC, simultaneous, PNP, short circuit protected;
- 5) bounce-free output signal;
- 6) wide operating temperature range;
- 7) signal LEDs for power supply and switching.

These features allow to resolve following issues:

- 1) problems due to contact bounces or very low voltages when connecting position switches to PLCs;
- 2) detection of light objects that require a contact block with high sensibility and reduced actuating forces;
- 3) when it is necessary to detect very small objects that require low differential travels;
- 4) When it is required to adjust the operating point: the internal LED precisely shows the switching point directly at the switch when you turn the adjusting screw;
- 5) in cases where the perfectly simultaneous switching of the two outputs is required;
- 6) detection of transparent objects or in any case where there are difficulties with normal sensors, taking into account that specialised sensors typically cost much more than this mechatronics device.



## Recommended installation

These switches are protected against electric interference of industrial environment.

When used under extreme conditions, as for example installed close to high surge voltages (electric motors, welding machines, etc.), it is advisable to adopt the following precautions:

- eliminate disturbances at the source;
- filter the DC power supply with adequate capacitor;
- separate the power cables from the switch cables;
- limit the cable length to max. 200 m.

It is equally important to take into account the voltage drops along the supply lines;

Reconnect and shield outgoing signal cables or use a shielded twisted-pair cable with suitable cross sections.

## Series connection of several E1 units (AND)

When connecting the switches in series (AND), following conditions must be fulfilled:

The output current of the first switch is the sum of the load current and the maximum currents absorbed by the other switches. Considering then the connection of the n switches, the nominal operating current "I<sub>e</sub>" becomes:

$$I_e = (200 - 20 \times n) \text{ mA}$$

Provided that I<sub>e</sub>: rated operating current  
n: number of switches connected in series

Example: with 3 switches it is possible to switch up to 140 mA.

Each switch causes a voltage drop in the connected-through state. The load must be suitable to operate at a voltage of:

$$U_c = U_a - 2 \times n$$

Provided that U<sub>c</sub>: rated operating voltage of the load  
U<sub>a</sub>: used supply voltage  
n: number of switches connected in series

Example: with 3 switches powered at 24 Vdc, the load must be able to work at 18 Vdc.

The maximum number of switches that can be connected in series depends on the supply voltage used. In any case, the number should be lower than:

$$no_{max} \leq \frac{V_a - 10}{2} + 1$$

Provided that no<sub>max</sub>: max. number of switches for series connection  
V<sub>a</sub>: supply voltage used

Example: at 24 Vdc it is possible to connect up to 7 switches. At 30 Vdc it is possible to connect up to 11 switches.

We recommend the installation of a commercially available diode for use with inductive loads (relays).

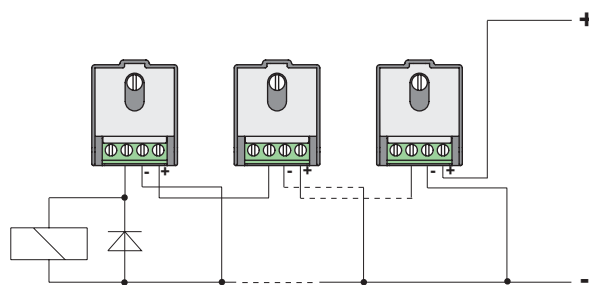

## Special loads

The switch is protected against overload and short-circuit, hence, it is required to limit possible load inrush currents. Typical examples are capacitors that require high current pulses during their charging and incandescent lamps whose resistance in cold state can be the tenth of the resistance in hot state. For capacitive loads, whenever necessary, connect a limiting resistance in series, while for lamps, whenever necessary, use a special preheating resistance.

## Limits of use

- **Not suitable for installations for safety applications.**
- Suitable for FD, FP, FL, FR, FM, FX and FZ series position switches only.

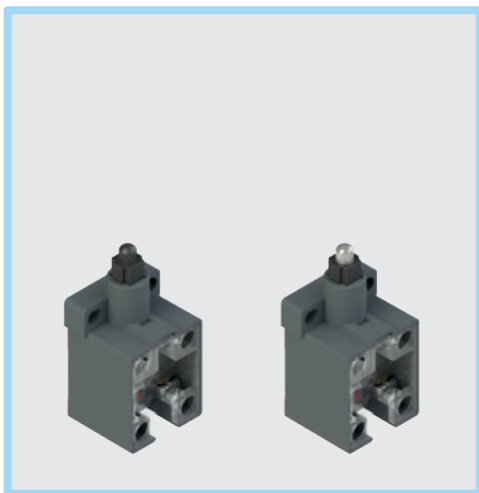

### Main features

- Technopolymer housing
- Protection degree IP20 (terminals), IP40 (contacts)
- 14 contact blocks available
- Actuators with plastic or metal plunger
- Contact block with positive opening ⊕
- For internal use in PA, PX, PC series foot switches

### Quality marks:



IMQ approval:	CA02.06217
UL approval:	E131787
CCC approval:	2021000305000102
EAC approval:	RU C-IT.YT03.B.00035/19

### Installation for safety applications:

Use only switches marked with the ⊕ symbol beside the product code. Always connect the safety circuit to the **NC contacts** (normally closed contacts: 11-12, 21-22 or 31-32) as required by **EN ISO 14119, paragraph 5.4** for specific interlock applications and **EN ISO 13849-2 table D3** (well-tried components) and **D.8** (fault exclusions) for safety applications in general. Actuate the switch **at least up to the positive opening travel** reported in the travel diagrams. Actuate the switch **at least with the positive opening force**, reported in brackets below each article, next to the minimum force value.

**⚠ If not expressly indicated in this chapter, for correct installation and utilization of all articles see the instructions given on pages 227 to 242.**

### Technical data

#### Housing

Housing made of glass fibre reinforced technopolymer, self-extinguishing and shock-proof  
 Protection degree acc. to EN 60529: IP20 (terminals)  
 IP40 (contacts)

#### General data

Ambient temperature:	-40°C ... +80°C
Safety parameter B <sub>10D</sub> :	40,000,000 for NC contacts
Max. actuation frequency:	3600 operating cycles/hour
Mechanical endurance:	20 million operating cycles
Max. actuation speed:	0.5 m/s
Min. actuation speed:	1 mm/s (slow action) 0.01 mm/s (snap action)
Tightening torque of the terminal screws:	0.6 ... 0.8 Nm
Wire cross-sections and wire stripping lengths:	see page 249

#### In compliance with standards:

IEC 60947-5-1, EN 60947-5-1, IEC 60947-1, IEC 60204-1, EN 60204-1, EN ISO 14119, EN ISO 12100, IEC 60529, EN 60529, EN IEC 63000, UL 508, CSA C22.2 No. 14, GB/T14048.5.

#### Approvals:

UL 508, CSA C22.2 No. 14, EN 60947-1, EN 60947-5-1.

#### Compliance with the requirements of:

Low Voltage Directive 2014/35/EU,  
 EMC Directive 2014/30/EU,  
 RoHS Directive 2011/65/EU.

#### Positive contact opening in conformity with standards:

IEC 60947-5-1, EN 60947-5-1.

### Electrical data

Thermal current (I <sub>th</sub> ):	10 A
Rated insulation voltage (U):	500 Vac 600 Vdc
Rated impulse withstand voltage (U <sub>imp</sub> ):	6 kV
Conditional short circuit current:	1000 A acc. to EN 60947-5-1
Protection against short circuits:	type aM fuse 10 A 500 V
Pollution degree:	3

### Utilization category

Alternating current: AC15 (50-60 Hz)			
Ue (V)	250	400	500
Ie (A)	6	4	1
Direct current: DC13			
Ue (V)	24	125	250
Ie (A)	3	0.55	0.3

### Features approved by IMQ

Rated insulation voltage (Ui):  
 500 Vac (for contact blocks [B] 5, 6, 7, 9, 10, 12, 13, 14, 15, 17, 18, 19, 66, 67)  
 400 Vac (for contact blocks [B] 11, 37)  
 Conventional free air thermal current (I<sub>th</sub>): 10 A  
 Protection against short circuits: type aM fuse 10 A 500 V  
 Rated impulse withstand voltage (U<sub>imp</sub>): 6 kV  
 Protection degree of the housing: IP20  
 MV terminals (screw terminals)  
 Pollution degree: 3  
 Utilization category: AC15  
 Operating voltage (Ue): 400 Vac (50/60 Hz)  
 Operating current (Ie): 4 A  
 Forms of the contact element: Zb, Y+Y, X+X, Y, X  
 Positive opening contacts on contact blocks [B] 5, 6, 7, 9, 11, 13, 14, 17, 18, 19, 37, 66  
 In compliance with standards: EN 60947-1, EN 60947-5-1, fundamental requirements of the Low Voltage Directive 2014/35/EU.

Please contact our technical department for the list of approved products.

### Features approved by UL

Electrical ratings: Q300 (69 VA, 125-250 Vdc)  
 A600 (720 VA, 120-600 Vac)  
 Housing features: open type.  
 For all contact blocks use 60 or 75°C copper (Cu) conductors, rigid or flexible, wire size 12, 14 AWG.  
 Tightening torque for terminal screws of 7.1 lb in (0.8 Nm).

Please contact our technical department for the list of approved products.



## Description



Contact block with captive screws, finger protection and self-lifting clamping screw plates. Provided with positive opening NC contacts for safety applications. Provided with twin bridge contacts, they are particularly suitable for high-reliability applications. Suitable for installation inside PA, PX and PC series foot switches (for more information see the General Catalogue HMI).

## Dimensional drawings

All values in the drawings are in mm

Contact type:

- R** = snap action
- L** = slow action
- LO** = slow action, make before break
- LS** = slow action, shifted
- LV** = slow action, shifted and spaced
- LA** = slow action, close

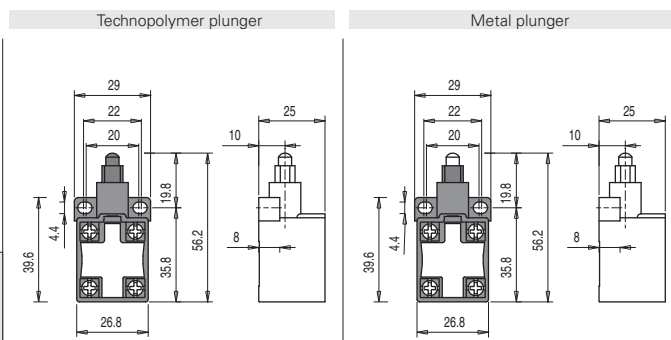

### Legend

- Closed contact
- Open contact
- Positive opening travel acc. to IEC 60947-5-1
- Pressing the switch
- Releasing the switch

Contact type	Technopolymer plunger		Metal plunger		Contact diagram	Travel diagram
	Article	Contacts	Article	Contacts		
<b>R</b>	VF B501	1NO+1NC	VF B502	1NO+1NC		
<b>L</b>	VF B601	1NO+1NC	VF B602	1NO+1NC		
<b>LO</b>	VF B701	1NO+1NC	VF B702	1NO+1NC		
<b>L</b>	VF B901	2NC	VF B902	2NC		
<b>L</b>	VF B1001	2NO	VF B1002	2NO		
<b>R</b>	VF B1101	2NC	VF B1102	2NC		
<b>R</b>	VF B1201	2NO	VF B1202	2NO		
<b>LV</b>	VF B1301	2NC	VF B1302	2NC		
<b>LS</b>	VF B1401	2NC	VF B1402	2NC		
<b>LS</b>	VF B1501	2NO	VF B1502	2NO		
<b>LA</b>	VF B1801	1NO+1NC	VF B1802	1NO+1NC		
<b>L</b>	VF B3701	1NO+1NC	VF B3702	1NO+1NC		
<b>L</b>	VF B6601	1NC	VF B6602	1NC		
<b>L</b>	VF B6701	1NO	VF B6702	1NO		
Max. speed	0,5 m/s		0,5 m/s			
Actuating force	8 N (20 N )		8 N (20 N )			

## Code structure

article options  
**VF B501-G**

Contact block	
<b>5</b>	1NO+1NC, snap action
<b>6</b>	1NO+1NC, slow action
<b>7</b>	1NO+1NC, slow action, make before break
<b>9</b>	2NC, slow action
<b>10</b>	2NO, slow action
<b>11</b>	2NC, snap action
<b>12</b>	2NO, snap action
...	...

Contact type	
	silver contacts (standard)
<b>G</b>	silver contacts with 1 µm gold coating
<b>G1</b>	silver contacts with 2.5 µm gold coating

Actuators	
<b>01</b>	with technopolymer plunger (standard)
<b>02</b>	with metal plunger

→ The 2D and 3D files are available at [www.pizzato.com](http://www.pizzato.com)

## FR 573-M2 signal switches with persistent contact

Contact type:

R = snap action

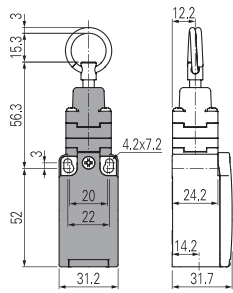

Contact block

5	R	FR 573-M2	1NO+1NC
11	R	FR 1173-M2	2NO
12	R	FR 1273-M2	2NC
Max. speed		0.5 m/s	
Actuating force		initial 20 N - final 40 N	

All values in the drawings are in mm

The switch is operated by traction of a rope connected to it and retains its state after actuation.

This means that the first actuation closes the contacts, the next actuation opens them, and so on.

This solution has been specifically designed to be applicable in all those situations where a floating switch is usually used to control a stepping relay, such as, for example, a device for switching on and off lights in rooms or for the opening / closing of gates.

Thanks to the retained actuation state, the first traction on the rope will enable, for example, the switching on of an illumination system, which can then be switched off by a subsequent traction.

The use of the switch alone makes the combinations of stepping relays and associated wiring unnecessary, greatly simplifying installation.

For more information see the General Catalogue Lifts by Pizzato Elettrica.

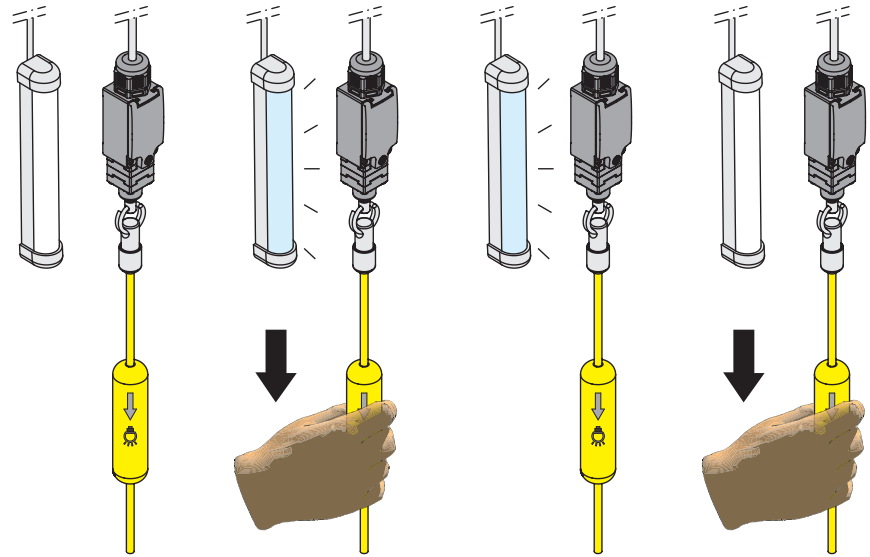

## FT series switches with electrical reset

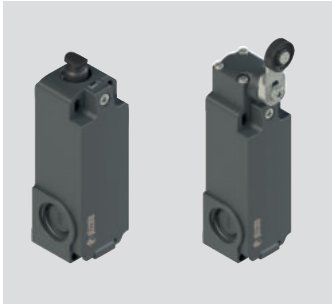

The FT series safety switches with reset retain their switching state when operated: their reset occurs electrically through the integrated solenoid. Thanks to this special feature, the switch can be remotely reset without having to go physically near it.

Available with 3 supply voltages of the solenoid (24 Vdc, 48 Vdc, 230 Vac) and with multiple actuators, the FT series switches are able to adapt to a wide variety of applications, particularly in the area of lifts, speed limiters and, more generally, in the world of security. Some models may also be manually reset.

Pizzato Elettrica has also introduced a new adjustment system integrated into the switch. It is designed specifically for speed limiter applications and allows a very fine and sensitive setting of the switch position along its vertical axis.

For more information see the General Catalogue Lifts by Pizzato Elettrica.

Operating principle

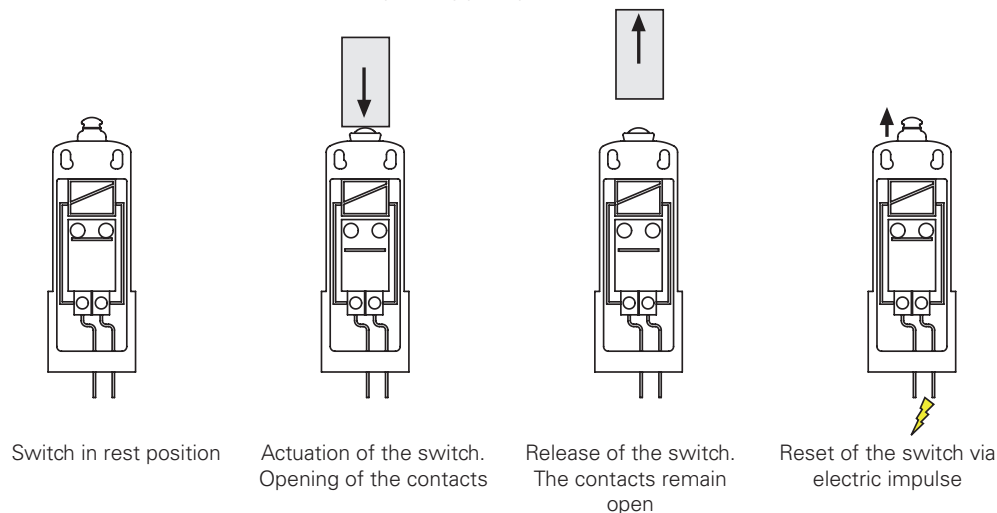



### Switches for switching cabinets - FR 5F1-M2, FR 10F1-M2

The FR 5F1-M2, FR 10F1-M2 switches are applied on electrical panel doors and are used when opening the door to turn on any signalling devices (e.g. three-phase flashing, etc.). Maintenance personnel of the panel can simulate the closing of the door by pressing the blue button. When maintenance is performed by simply closing the switching cabinet door, the switch functionality will be automatically reset.

Contact type:  
**R** = snap action  
**L** = slow action

Contact block	
5 <b>R</b>	FR 5F1-M2 $\rightarrow$ 1NO+1NC 
10 <b>L</b>	FR 10F1-M2 2NO 
Max. speed	page 229 - type 4
Actuating force	8 N (25 N $\rightarrow$ )

All values in the drawings are in mm

FR 5F1-M2 operating principle

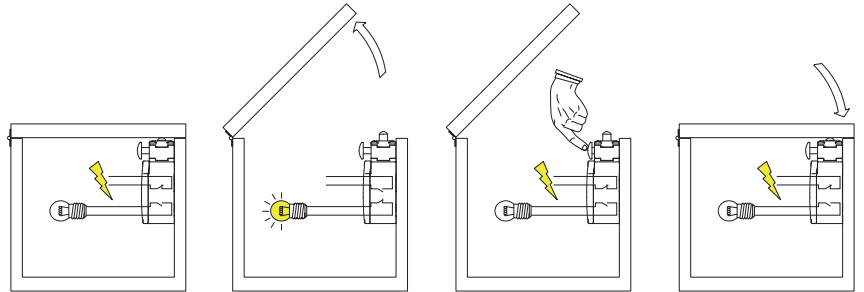

FR 10F1-M2 operating principle

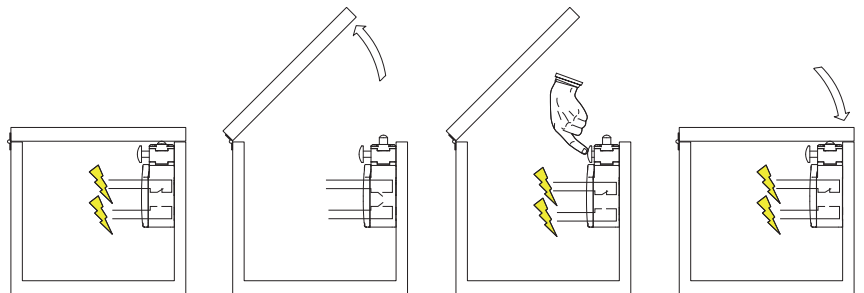

**⚠** If not expressly indicated in this chapter, for correct installation and utilization of all articles see the instructions given on pages 227 to 242.

### Switches for switching cabinets - FR 37F1-M2

The present switch and the one described above have a similar operation principle. Pressing the switch button simulates the closing of the door powering the auxiliary circuit again while still leaving the light on that will only be turned off when the door is closed.

Contact type:  
**L** = slow action

Contact block	
37 <b>L</b>	FR 37F1-M2 $\rightarrow$ 1NO+1NC 
Max. speed	page 229 - type 4
Actuating force	8 N (25 N $\rightarrow$ )

FR 37F1-M2 operating principle

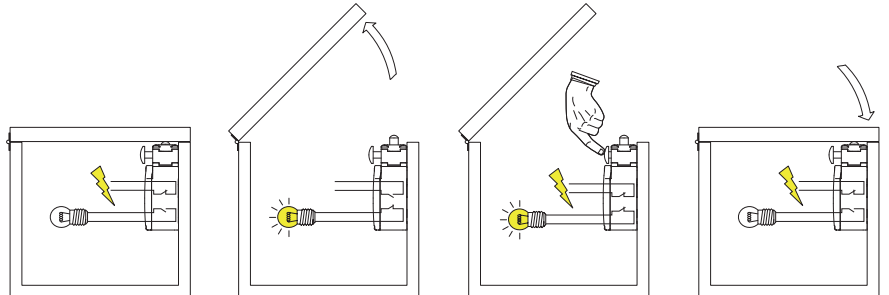

**⚠** If not expressly indicated in this chapter, for correct installation and utilization of all articles see the instructions given on pages 227 to 242.

## Description



Pizzato Elettrica offers a wide range of products suitable for places where chemical and corrosive agents are used and for aseptic places where particular attention must be paid to cleanliness and hygiene.

The technopolymer housings and external metal parts in stainless steel allow these devices to be used for a variety of applications, ranging from the food and pharmaceutical sectors to the chemical and marine sectors.

## Main features:

- Technopolymer housings
- External metallic parts exclusively in stainless steel
- Protection degree IP67 (FW, FP series switches)
- Protection degree IP67 and IP69K (FR, FX, FK series sensors)
- Protection degree IP67 and IP69K (SR, ST, HX series sensors)

## Resistance against corrosion

Substance	Stainless steel	Technopolymer	Substance	Stainless steel	Technopolymer
Acetylene	■	■	Whisky malt	■	■
Vinegar	■	■	Molasses	■	■
Acetone	■	■	Nickel chloride	□	□
Acetic acid	■	□	Aluminium nitrate	■	■
Boric acid	■	■	Combustible oils	■	■
Citric acid	■	■	Tanning oil	■	-
Hydrochloric acid 100%	□	□	Linseed oil	■	■
Chromic acid 5%	■	□	Hydraulic oil (synthetic)	■	■
Hydrofluoric acid 100%	■	□	Mineral Oil	■	■
Formic acid	■	□	Motor Oil	■	■
Phosphoric acid (<40%)	□	■	Transformer oil	■	■
Lactic acid	■	■	Paraffin	■	■
Nitric acid (concentrated)	■	□	Potassium chloride	■	■
Oleic acid	■	■	Potassium hydroxide (caustic potash)	■	□
Sulphuric acid (<10%)	■	□	Potassium sulphate	■	■
Sulphuric acid (10-75%)	□	□	Propane (liquid)	■	■
Sulphuric acid (75-100%)	□	□	Copper sulphate >5%	■	□
Stearic acid	■	■	Liquid soaps	■	■
Tartaric acid	□	■	Chocolate syrup	■	■
White water	■	■	Milk whey	■	-
Sea water	□	■	Sodium bicarbonate	■	■
Distilled water	■	■	Sodium bisulphate	□	■
White spirit	■	■	Sodium carbonate	■	■
Ethyl alcohol	■	■	Sodium chloride	■	■
Methyl alcohol	■	■	Sodium hydroxide (80%)	■	□
Liquid ammonia	■	■	Sodium hypochlorite (100%)	□	□
Ammonium acetate	■	■	Sodium nitrate	■	■
Ammonium carbonate	■	■	Sodium sulphate	■	■
Ammonium sulfate	■	■	Sodium sulphide	□	■
Leaded petrol	■	■	Aluminium sulphate	■	■
Unleaded petrol	■	■	Ferrous sulphate	■	■
Benzol	■	□	Calcium hydroxide	□	■
Beer	■	■	Potassium hydroxide	■	■
Butane	■	■	Sodium hydroxide	-	■
Butanol	■	■	Tanning solutions	■	■
Quicklime	■	■	Photographic solutions	-	■
Calcium chloride	■	■	Fruit juice	■	■
Calcium hydroxide	■	■	Vegetable juice	■	■
Chloroform	■	■	Toluene	■	□
Aluminium chloride	■	■	Transparent (paint)	■	-
Ferrous chloride	□	□	Trichloroethylene	■	■
Chrome plating	□	□	Whisky and wine	■	■
Diesel	■	■	Zinc plate	□	□
Ether	■	■	Zinc chloride	■	■
Formaldehyde 100%	■	□	Zinc sulphate	-	■
Furfural	■	■	Sulphur chloride	■	■
Gelatine	■	■	Sugar (liquid)	■	■
Glycerine	■	■	Sugar beet	■	■
Glucose	■	■			
Shellac (orange)	■	■			
Hydrogen (gas)	■	■			
Iodine	□	■			
Milk	■	■			
Magnesium chloride	□	■			
Magnesium hydroxide	■	■			
Magnesium sulphate (Epsom salt)	■	■			
Mayonnaise	■	■			

## Resistance against corrosion

- No corrosion
- Possible corrosion
- Corrosion
- Data not available



Contact type							
<b>R</b>	= snap action						
<b>L</b>	= slow action						
Contact block							
2	<b>R</b>	FR 201-XM2	2x(1NO-1NC)	FR 202-XM2	2x(1NO-1NC)	FR 205-XM2	2x(1NO-1NC)
5	<b>R</b>	FR 501-XM2	1NO+1NC	FR 502-XM2	1NO+1NC	FR 505-XM2	1NO+1NC
6	<b>L</b>	FR 601-XM2	1NO+1NC	FR 602-XM2	1NO+1NC	FR 605-XM2	1NO+1NC
9	<b>L</b>	FR 901-XM2	2NC	FR 902-XM2	2NC	FR 905-XM2	2NC
20	<b>L</b>	FR 2001-XM2	1NO+2NC	FR 2002-XM2	1NO+2NC	FR 2005-XM2	1NO+2NC
Max. speed		page 231 - type 4		page 231 - type 3		page 231 - type 3	
Actuating force		8 N (25 N ⊕)		6 N (25 N ⊕)		6 N (25 N ⊕)	
Travel diagrams		page 232 - group 1		page 232 - group 2		page 232 - group 2	

Contact type				External gasket		External gasket	
<b>R</b>	= snap action						
<b>L</b>	= slow action						
Contact block							
2	<b>R</b>	FR 215-XM2	2x(1NO-1NC)	FR 220-XM2	2x(1NO-1NC)	FR 230-XM2V38	2x(1NO-1NC)
5	<b>R</b>	FR 515-XM2	1NO+1NC	FR 5A1-XM2	1NO+1NC	FR 530-XM2V38	1NO+1NC
6	<b>L</b>	FR 615-XM2	1NO+1NC	FR 6A1-XM2	1NO+1NC	FR 630-XM2V38	1NO+1NC
9	<b>L</b>	FR 915-XM2	2NC	FR 9A1-XM2	2NC	FR 930-XM2V38	2NC
20	<b>L</b>	FR 2015-XM2	1NO+2NC	FR 20A1-XM2	1NO+2NC	FR 2030-XM2V38	1NO+2NC
Max. speed		page 231 - type 2		page 231 - type 4		page 231 - type 1	
Actuating force		8 N (25 N ⊕)		6 N (25 N ⊕)		0.07 Nm	
Travel diagrams		page 232 - group 1		page 232 - group 1		page 232 - group 4	

Contact type							
<b>R</b>	= snap action						
<b>L</b>	= slow action						
Contact block							
2	<b>R</b>	FR 231-XM2V38	2x(1NO-1NC)	FR 251-XM2V38	2x(1NO-1NC)	FR 254-XM2V38	2x(1NO-1NC)
5	<b>R</b>	FR 531-XM2V38	1NO+1NC	FR 551-XM2V38	1NO+1NC	FR 554-XM2V38	1NO+1NC
6	<b>L</b>	FR 631-XM2V38	1NO+1NC	FR 651-XM2V38	1NO+1NC	FR 654-XM2V38	1NO+1NC
9	<b>L</b>	FR 931-XM2V38	2NC	FR 951-XM2V38	2NC	FR 954-XM2V38	2NC
20	<b>L</b>	FR 2031-XM2V38	1NO+2NC	FR 2051-XM2V38	1NO+2NC	FR 2054-XM2V38	1NO+2NC
Max. speed		page 231 - type 1		page 231 - type 1		page 231 - type 1	
Actuating force		0.06 Nm (0.25 Nm ⊕)		0.06 Nm (0.25 Nm ⊕)		0.06 Nm (0.25 Nm ⊕)	
Travel diagrams		page 232 - group 5		page 232 - group 5		page 232 - group 5	

All values in the drawings are in mm

Accessories See page 207

→ The 2D and 3D files are available at [www.pizzato.com](http://www.pizzato.com)

# Switches with external parts in stainless steel

Contact type								
<b>R</b> = snap action								
<b>L</b> = slow action								
2	<b>R</b>	FX 201-XM2	2x(1NO-1NC)	FX 202-XM2	2x(1NO-1NC)	FX 205-XM2	2x(1NO-1NC)	
5	<b>R</b>	FX 501-XM2	1NO+1NC	FX 502-XM2	1NO+1NC	FX 505-XM2	1NO+1NC	
6	<b>L</b>	FX 601-XM2	1NO+1NC	FX 602-XM2	1NO+1NC	FX 605-XM2	1NO+1NC	
9	<b>L</b>	FX 901-XM2	2NC	FX 902-XM2	2NC	FX 905-XM2	2NC	
20	<b>L</b>	FX 2001-XM2	1NO+2NC	FX 2002-XM2	1NO+2NC	FX 2005-XM2	1NO+2NC	
Max. speed	page 231 - type 4		page 231 - type 3		page 231 - type 3		page 231 - type 3	
Actuating force	8 N (25 N ⊕)		6 N (25 N ⊕)		6 N (25 N ⊕)		4 N (25 N ⊕)	
Travel diagrams	page 232 - group 1		page 232 - group 2		page 232 - group 2		page 232 - group 3	

Contact type				External gasket		External gasket		
<b>R</b> = snap action								
<b>L</b> = slow action								
2	<b>R</b>	FX 215-XM2	2x(1NO-1NC)	FX 220-XM2	2x(1NO-1NC)	FX 225-XM2	2x(1NO-1NC)	
5	<b>R</b>	FX 515-XM2	1NO+1NC	FX 520-XM2	1NO+1NC	FX 525-XM2	1NO+1NC	
6	<b>L</b>	FX 615-XM2	1NO+1NC	/	/	FX 630-XM2V38	1NO+1NC	
9	<b>L</b>	FX 915-XM2	2NC	/	/	FX 930-XM2V38	2NC	
20	<b>L</b>	FX 2015-XM2	1NO+2NC	FX 2020-XM2	1NO+2NC	FX 2025-XM2	1NO+2NC	
Max. speed	page 231 - type 2		1 m/s		1 m/s		page 231 - type 1	
Actuating force	8 N (25 N ⊕)		0.07 Nm		0.12 Nm		0.06 Nm (0.25 Nm ⊕)	
Travel diagrams	page 232 - group 1		page 232 - group 4		page 232 - group 4		page 232 - group 5	

Contact type								
<b>R</b> = snap action								
<b>L</b> = slow action								
2	<b>R</b>	FX 231-XM2V38	2x(1NO-1NC)	FX 251-XM2V38	2x(1NO-1NC)	FX 254-XM2V38	2x(1NO-1NC)	
5	<b>R</b>	FX 531-XM2V38	1NO+1NC	FX 551-XM2V38	1NO+1NC	FX 554-XM2V38	1NO+1NC	
6	<b>L</b>	FX 631-XM2V38	1NO+1NC	FX 651-XM2V38	1NO+1NC	FX 654-XM2V38	1NO+1NC	
9	<b>L</b>	FX 931-XM2V38	2NC	FX 951-XM2V38	2NC	FX 954-XM2V38	2NC	
20	<b>L</b>	FX 2031-XM2V38	1NO+2NC	FX 2051-XM2V38	1NO+2NC	FX 2054-XM2V38	1NO+2NC	
Max. speed	page 231 - type 1		page 231 - type 1		page 231 - type 1		page 231 - type 1	
Actuating force	0.06 Nm (0.25 Nm ⊕)		0.06 Nm (0.25 Nm ⊕)		0.06 Nm (0.25 Nm ⊕)		0.06 Nm (0.25 Nm ⊕)	
Travel diagrams	page 232 - group 5		page 232 - group 5		page 232 - group 5		page 232 - group 5	

All values in the drawings are in mm

Accessories See page 207

→ The 2D and 3D files are available at [www.pizzato.com](http://www.pizzato.com)



Contact type							
<b>R</b>	= snap action						
<b>L</b>	= slow action						

Contact block								
3 <b>R</b>	FK 301-XM1	1NO+1NC	FK 302-XM1	1NO+1NC	FK 305-XM1	1NO+1NC	FK 307-XM1	1NO+1NC
33 <b>L</b>	FK 3301-XM1	1NO+1NC	FK 3302-XM1	1NO+1NC	FK 3305-XM1	1NO+1NC	FK 3307-XM1	1NO+1NC
34 <b>L</b>	FK 3401-XM1	2NC	FK 3402-XM1	2NC	FK 3405-XM1	2NC	FK 3407-XM1	2NC
Max. speed	page 231 - type 4		page 231 - type 3		page 231 - type 3		page 231 - type 3	
Actuating force	8 N (25 N)		6 N (25 N)		6 N (25 N)		4 N (25 N)	
Travel diagrams	page 232 - group 1		page 232 - group 2		page 232 - group 2		page 232 - group 3	

Contact type				External gasket		External gasket	
<b>R</b>	= snap action						
<b>L</b>	= slow action						

Contact block								
3 <b>R</b>	FK 315-XM1	1NO+1NC	FK 320-XM1	1NO-1NC	FK 325-XM1	1NO-1NC	FK 330-XM1V38	1NO+1NC
33 <b>L</b>	FK 3315-XM1	1NO+1NC	FK 3320-XM1	1NO+1NC	FK 3325-XM1	1NO+1NC	FK 3330-XM1V38	1NO+1NC
34 <b>L</b>	FK 3415-XM1	2NC	FK 3420-XM1	2NC	FK 3425-XM1	2NC	FK 3430-XM1V38	2NC
Max. speed	page 231 - type 2		1 m/s		1 m/s		page 231 - type 1	
Actuating force	8 N (25 N)		0.05 Nm		0.1 Nm		0.06 Nm (0.25 Nm)	
Travel diagrams	page 232 - group 1		page 232 - group 4		page 232 - group 4		page 232 - group 5	

Contact type							
<b>R</b>	= snap action						
<b>L</b>	= slow action						

Contact block								
3 <b>R</b>	FK 331-XM1V38	1NO+1NC	FK 351-XM1V38	1NO+1NC	FK 354-XM1V38	1NO+1NC	FK 356-XM1V38	1NO+1NC
33 <b>L</b>	FK 3331-XM1V38	1NO+1NC	FK 3351-XM1V38	1NO+1NC	FK 3354-XM1V38	1NO+1NC	FK 3356-XM1V38	1NO+1NC
34 <b>L</b>	FK 3431-XM1V38	2NC	FK 3451-XM1V38	2NC	FK 3454-XM1V38	2NC	FK 3456-XM1V38	2NC
Max. speed	page 231 - type 1		page 231 - type 1		page 231 - type 1		page 231 - type 1	
Actuating force	0.06 Nm (0.25 Nm)		0.06 Nm (0.25 Nm)		0.06 Nm (0.25 Nm)		0.06 Nm (0.25 Nm)	
Travel diagrams	page 232 - group 5		page 232 - group 5		page 232 - group 5		page 232 - group 5	

All values in the drawings are in mm

Accessories See page 207

→ The 2D and 3D files are available at [www.pizzato.com](http://www.pizzato.com)

Contact type  
**R** = snap action  
**L** = slow action

Contact block

2	<b>R</b>	FP 201-XM2	2x(1NO-1NC)	FP 202-XM2	2x(1NO-1NC)	FP 205-XM2	2x(1NO-1NC)	FP 208-XM2	2x(1NO-1NC)
5	<b>R</b>	FP 501-XM2	⊕ 1NO+1NC	FP 502-XM2	⊕ 1NO+1NC	FP 505-XM2	⊕ 1NO+1NC	FP 508-XM2	⊕ 1NO+1NC
6	<b>L</b>	FP 601-XM2	⊕ 1NO+1NC	FP 602-XM2	⊕ 1NO+1NC	FP 605-XM2	⊕ 1NO+1NC	FP 608-XM2	⊕ 1NO+1NC
9	<b>L</b>	FP 901-XM2	⊕ 2NC	FP 902-XM2	⊕ 2NC	FP 905-XM2	⊕ 2NC	FP 908-XM2	⊕ 2NC
20	<b>L</b>	FP 2001-XM2	⊕ 1NO+2NC	FP 2002-XM2	⊕ 1NO+2NC	FP 2005-XM2	⊕ 1NO+2NC	FP 2008-XM2	⊕ 1NO+2NC
Max. speed		page 229 - type 4		page 229 - type 3		page 229 - type 3		page 229 - type 4	
Actuating force		8 N (25 N ⊕)		6 N (25 N ⊕)		6 N (25 N ⊕)		8 N (25 N ⊕)	
Travel diagrams		page 230 - group 1		page 230 - group 2		page 230 - group 2		page 230 - group 1	

Contact type  
**R** = snap action  
**L** = slow action

External gasket

Contact block

2	<b>R</b>	FP 210-XM2	2x(1NO-1NC)	FP 211-XM2	2x(1NO-1NC)	FP 216-XM2	2x(1NO-1NC)
5	<b>R</b>	FP 510-XM2	⊕ 1NO+1NC	FP 511-XM2	⊕ 1NO+1NC	FP 516-XM2	⊕ 1NO+1NC
6	<b>L</b>	FP 610-XM2	⊕ 1NO+1NC	FP 611-XM2	⊕ 1NO+1NC	FP 616-XM2	⊕ 1NO+1NC
9	<b>L</b>	FP 910-XM2	⊕ 2NC	FP 911-XM2	⊕ 2NC	FP 916-XM2	⊕ 2NC
20	<b>L</b>	FP 2010-XM2	⊕ 1NO+2NC	FP 2011-XM2	⊕ 1NO+2NC	FP 2016-XM2	⊕ 1NO+2NC
Max. speed		page 229 - type 4		page 229 - type 4		page 229 - type 2	
Actuating force		11 N (25 N ⊕)		8 N (25 N ⊕)		8 N (25 N ⊕)	
Travel diagrams		page 230 - group 1		page 230 - group 1		page 230 - group 1	

## Safety switches for hinges

Contact type  
**L** = slow action

Contact block

9	<b>L</b>	FR 996-XM2	⊕ 2NC	FX 996-XM2	⊕ 2NC	/	
18	<b>L</b>	FR 1896-XM2	⊕ 1NO+1NC	FX 1896-XM2	⊕ 1NO+1NC	/	
20	<b>L</b>	FR 2096-XM2	⊕ 1NO+2NC	FX 2096-XM2	⊕ 1NO+2NC	/	
33	<b>L</b>	/	/	/	/	FK 3396-XM1	⊕ 1NO+1NC
34	<b>L</b>	/	/	/	/	FK 3496-XM1	⊕ 2NC
Actuating force		0.15 Nm (0.4 Nm ⊕)		0.15 Nm (0.4 Nm ⊕)		0.15 Nm (0.4 Nm ⊕)	
Travel diagrams		page 234 - group 9		page 234 - group 9		page 234 - group 9	

**⚠ If not expressly indicated in this chapter, for correct installation and utilization of all articles see the instructions given on pages 227 to 242.**



## Safety switches with separate actuator

Contact type  
 = slow action

	Without actuator	Without actuator	Without actuator	Without actuator
FR 693-XM2				
FR 993-XM2				
FR 2093-XM2				
FR 3393-XM1	/	/	/	
FR 3493-XM1	/	/	/	
Actuating force	10 N (18 N )	10 N (18 N )	10 N (18 N )	10 N (18 N )
Travel diagrams	page 234 - group 8	page 234 - group 8	page 234 - group 8	page 234 - group 8

## Stainless steel actuators

**IMPORTANT:** These actuators can be used only with items of the FR, FX, FK and FW series (e.g. FR 693-XM2).  
 Low level of coding acc. to EN ISO 14119.

Article	Description	Article	Description
VF KEYD	Straight actuator	VF KEYD1	Angled actuator
VF KEYD5	Extended actuator	VF KEYD6	Extended actuator, angled
VF KEYD8	Universal actuator	VF KEYD10	Profiled actuator

### SR series magnetic safety sensors



See  
 General Catalogue Safety 2023-2024

### ST series RFID safety sensors



See  
 General Catalogue Safety 2023-2024

### HX series stainless steel safety switches



See  
 General Catalogue Safety 2023-2024

All values in the drawings are in mm

Accessories See page 207

→ The 2D and 3D files are available at [www.pizzato.com](http://www.pizzato.com)

## M12 connectors



- M12 male connectors with cable ▶ 209
- M12 female connectors with cable ▶ 210
- M12 male connectors for panel mounting ▶ 211
- Field wireable M12 female connectors ▶ 212
- Field wireable M12 male connectors ▶ 212

## M12 connectors, for series connections



- M12 extension cables ▶ 213
- M12 connectors, Y-shaped ▶ 214
- M12 terminating plugs for series connections ▶ 214

## M23 connectors



- M23 male connectors for panel mounting ▶ 215
- M23 female connectors for panel mounting ▶ 216
- M23 female connectors with cable ▶ 217
- Field wireable M23 female connectors ▶ 218
- M23 extension cables with male and female connector ▶ 219

## M8 connectors



- M8 female connectors with cable ▶ 220



## Cable glands and adapters



Strain relief cable glands  
Thread adapters  
Protection caps  
Threaded nuts  
Chock plugs

▶ 221  
▶ 221  
▶ 222  
▶ 222  
▶ 222

## Tampering protection for M12 connectors

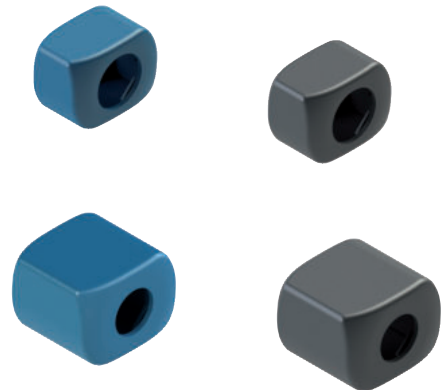

Tampering protection for M12 connectors

▶ 223

## LED signalling lights



LED signalling lights

▶ 224

## Fixing screws and plates

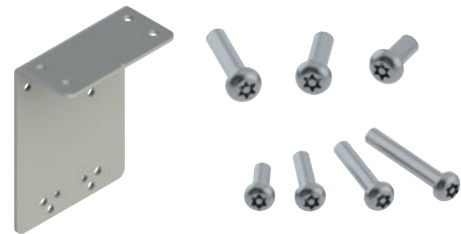

Fixing plates  
Torx safety screws  
OneWay safety screws  
Bits for Torx safety screws

▶ 225  
▶ 225  
▶ 225  
▶ 225

## Junction box for series connections



Junction box for series connection of up to 4 devices

▶ 226

## M12 male connectors with cable



## Features:

- Polyurethane connector body
- Class 6 copper conductors acc. to IEC 60228 - mobile installation
- Gold-plated contacts
- Anti-vibration self-locking ring nut
- High flexibility cable with oil resistant PVC or PUR sheath suitable to be used in drag chains, acc. to IEC 60332-1-2

Max. operating voltage:	250 Vac / 300 Vdc (4/5-pole) 30 Vac / 36 Vdc (8/12-pole)
Max. operating current:	4 A (4-5-pole); 2 A (8-pole); 1.5 A (12-pole)
Protection degree:	IP67 acc. to EN 60529, IP69K acc. to ISO 20653 (Protect the cables from direct high-pressure and high-temperature jets)
Ambient temperature:	-25°C ... +80°C, PVC sheath, fixed installation -15°C ... +80°C, PVC sheath, mobile installation -40°C ... +80°C, PUR sheath, fixed installation -25°C ... +80°C, PUR sheath, mobile installation
Wire cross-sections:	0.34 mm <sup>2</sup> (22 AWG) for 4-pole 0.25 mm <sup>2</sup> (23 AWG) for 5/8-pole 0.14 mm <sup>2</sup> (26 AWG) for 12-pole
Minimum bending radius:	> cable diameter x 15
Tightening torque of the ring:	0.6 ... 0.8 Nm

## Pin assignment

5 poles		8 poles	
Pin	Colour	Pin	Colour
1	Brown	1	White
2	White	2	Brown
3	Blue	3	Green
4	Black	4	Yellow
5	Grey	5	Grey
		6	Pink
		7	Blue
		8	Red

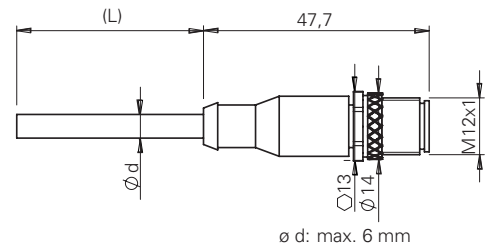

## Code structure

**Attention!** The feasibility of a code number does not mean the effective availability of a product. Please contact our sales office.

article options  
**VF CF5PD3M-X**

<b>No. of poles</b>	<b>Connection type</b>	<b>Fixing ring</b>
<b>4</b> 4 poles	<b>M</b> M12x1	knurled ring (standard)
<b>5</b> 5 poles		<b>X</b> stainless steel hex ring nut
<b>8</b> 8 poles		
<b>12</b> 12 poles		
<b>Cable sheath</b>	<b>Cable length (L)</b>	
<b>P</b> PVC (standard)	<b>1</b> 1 metre	
<b>U</b> PUR	<b>2</b> 2 metres	
	<b>3</b> 3 metres (standard)	
	<b>4</b> 4 metres	
	<b>5</b> 5 metres (standard)	
	<b>...</b>	
	<b>10</b> 10 metres (standard)	
<b>Connector type</b>	Other lengths on request.	
<b>D</b> straight (standard)		
<b>G</b> angled		

## Stock items

VF CF5PD3M  
VF CF8PD3M

**Attention!** For items not in stock the minimum order quantity is 100 pcs.

**ATTENTION:** always disconnect the power supply before removing the connector. The connector is not suitable for separation of electrical loads.

All values in the drawings are in mm

→ The 2D and 3D files are available at [www.pizzato.com](http://www.pizzato.com)

## M12 female connectors with cable



### Features:

- Polyurethane connector body
- Class 6 copper conductors acc. to IEC 60228 - mobile installation
- Gold-plated contacts
- Anti-vibration self-locking ring nut made of nickel-plated brass, available on request in AISI 316L stainless steel hex version
- High flexibility cable with oil resistant PVC or PUR sheath suitable to be used in drag chains, acc. to IEC 60332-1-2

Max. operating voltage:	250 Vac / 300 Vdc (4/5-pole) 30 Vac / 36 Vdc (8/12-pole)
Max. operating current:	4 A (4-5-pole); 2 A (8-pole); 1.5 A (12-pole)
Protection degree:	IP67 acc. to EN 60529, IP69K acc. to ISO 20653 (Protect the cables from direct high-pressure and high-temperature jets)
Ambient temperature:	-25°C ... +80°C, PVC sheath, fixed installation -15°C ... +80°C, PVC sheath, mobile installation -40°C ... +80°C, PUR sheath, fixed installation -25°C ... +80°C, PUR sheath, mobile installation
Wire cross-sections:	0.34 mm <sup>2</sup> (22 AWG) for 4-pole 0.25 mm <sup>2</sup> (23 AWG) for 5/8-pole 0.14 mm <sup>2</sup> (26 AWG) for 12-pole
Minimum bending radius:	> cable diameter x 15
Tightening torque of the ring:	0.6 ... 0.8 Nm

### Pin assignment

4 poles		5 poles		8 poles		12 poles	
Pin	Colour	Pin	Colour	Pin	Colour	Pin	Colour
1	Brown	1	Brown	1	White	1	Brown
2	White	2	White	2	Brown	2	Blue
3	Blue	3	Blue	3	Green	3	White
4	Black	4	Black	4	Yellow	4	Green
		5	Grey	5	Grey	5	Pink
				6	Pink	6	Yellow
				7	Blue	7	Black
				8	Red	8	Grey
						9	Red
						10	Purple
						11	Grey-Pink
						12	Red-Blue

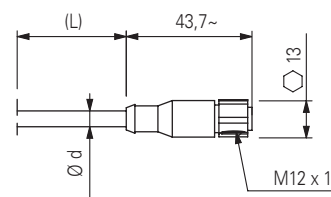
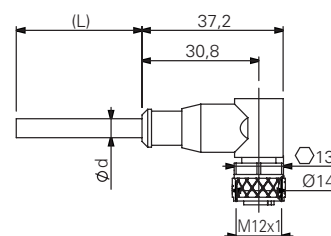
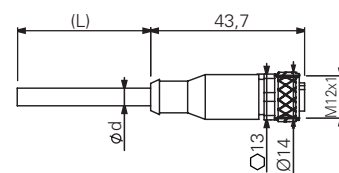

ø d: max. 6 mm

### Code structure

**Attention!** The feasibility of a code number does not mean the effective availability of a product. Please contact our sales office.

article		options	
<b>VF CA4PD3M-X</b>			
<b>No. of poles</b>		<b>Connection type</b>	
<b>4</b> 4 poles		<b>M</b> M12x1	
<b>5</b> 5 poles			
<b>8</b> 8 poles		<b>Fixing ring</b>	
<b>12</b> 12 poles			knurled ring (standard)
		<b>X</b>	stainless steel hex ring nut
<b>Cable sheath</b>		<b>Cable length (L)</b>	
<b>P</b> PVC (standard)		<b>1</b> 1 metre	
<b>U</b> PUR		<b>2</b> 2 metres	
		<b>3</b> 3 metres (standard)	
<b>Connector type</b>		<b>4</b> 4 metres	
<b>D</b> straight (standard)		<b>5</b> 5 metres (standard)	
<b>G</b> angled		<b>...</b>	
		<b>10</b> 10 metres (standard)	
		Other lengths on request.	

### Stock items

VF CA4PD3M
VF CA4PD5M
VF CA4PD10M
VF CA5PD3M
VF CA5PD5M
VF CA5PD10M
VF CA8PD3M
VF CA8PD5M
VF CA8PD10M
VF CA8PD20M
VF CA12PD3M
VF CA12PD5M
VF CA12PD10M
VF CA12PD20M
VF CA12PD30M
VF CA8UD5M-X
VF CA8UD10M-X
VF CA12UD10M-X

**Attention!** For items not in stock the minimum order quantity is 100 pcs.

**ATTENTION:** always disconnect the power supply before removing the connector. The connector is not suitable for separation of electrical loads.

All values in the drawings are in mm

→ The 2D and 3D files are available at [www.pizzato.com](http://www.pizzato.com)

## M12 male connectors for panel mounting



## Features:

- Technopolymer or metal connector body
- Gold-plated contacts
- Wires with crimped ferrules
- Directly installable on the device, these ensure quick replacement, reducing machine down time

Max. operating voltage:	250 Vac / 300 Vdc (4/5-pole) 30 Vac / 36 Vdc (8/12-pole)
Max. operating current:	4 A (4/5-pole) 2 A (8-pole) 1.5 A (12-pole)
Protection degree:	IP67 acc. to EN 60529 IP69K acc. to ISO 20653
Ambient temperature:	-25°C ... +80°C
Tightening torque:	1 ... 1.5 Nm
Wire cross-sections:	0.5 mm <sup>2</sup> (20 AWG) for 4/5-pole 0.25 mm <sup>2</sup> (23 AWG) for 8-pole 0.14 mm <sup>2</sup> (26 AWG) for 12-pole
Contact type:	gold-plated

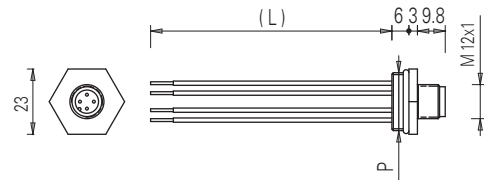

## Pin assignment

4 poles		5 poles		8 poles		12 poles	
Pin	Colour	Pin	Colour	Pin	Colour	Pin	Colour
1	Brown	1	Brown	1	White	1	Brown
2	White	2	White	2	Brown	2	Blue
3	Blue	3	Blue	3	Green	3	White
4	Black	4	Black	4	Yellow	4	Green
		5	Grey	5	Grey	5	Pink
				6	Pink	6	Yellow
				7	Blue	7	Black
				8	Red	8	Grey
						9	Red
						10	Purple
						11	Grey-Pink
						12	Red-Blue

## Code structure

**Attention!** The feasibility of a code number does not mean the effective availability of a product. Please contact our sales office.

article		options	
<b>VF CNM5MM-L100</b>			
<b>Body material</b>		<b>Wire length (L)</b>	
<b>M</b> metal		8.5 cm (standard)	
<b>P</b> plastic		<b>L16</b> 16 cm	
		<b>L100</b> 100 cm	
		<b>L200</b> 200 cm	
<b>No. of poles</b>		<b>Connection type</b>	
<b>4</b> 4 poles		<b>M</b> M12x1	
<b>5</b> 5 poles			
<b>8</b> 8 poles		<b>Connector thread (P)</b>	
<b>12</b> 12 poles		<b>M</b> M20 x 1.5 (standard)	
		<b>P</b> PG 13.5	

## Stock items

VF CNP4MM
VF CNP4PM
VF CNP5MM
VF CNP5PM
VF CNP8MM
VF CNM4MM
VF CNM4PM
VF CNM5MM
VF CNM5PM
VF CNM8MM
VF CNM8PM
VF CNM12MM-L16

**ATTENTION:** always disconnect the power supply before removing the connector. The connector is not suitable for separation of electrical loads.

**Note:** the 12-pole connector is only available in metal with M20x1.5 thread and 16 cm wires.

## Field wireable M12 female connectors



### Features:

- Technopolymer connector body
- Gold-plated contacts
- Screw terminals for cable screw fittings

Max. operating voltage:	250 Vac/dc (4 and 5-pole) 30 Vac/dc (8-pole)
Max. operating current:	4 A (4 and 5-pole) 2 A (8-pole)
Protection degree:	IP67 acc. to EN 60529
Ambient temperature:	-25°C ... +85°C
Wire cross-sections:	0.25 mm <sup>2</sup> (23 AWG) ... 0.5 mm <sup>2</sup> (20 AWG)
Tightening torque of the ring:	0.6 ... 0.8 Nm

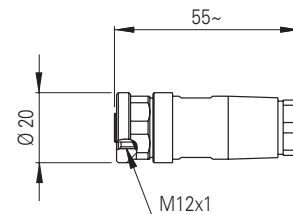

Article	Description	no. of poles
VF CBMP4DM04	Field wireable M12 female connector, straight, for Ø 4 ... 6.5 mm multipolar cables	4
VF CBMP5DM04	Field wireable M12 female connector, straight, for Ø 4 ... 6.5 mm multipolar cables	5
VF CBMP8DM04	Field wireable M12 female connector, straight, for Ø 4 ... Ø 7 mm multipolar cables	8

## Field wireable M12 male connectors



### Features:

- Technopolymer connector body
- Gold-plated contacts
- Screw terminals for cable screw fittings

Max. operating voltage:	250 Vac/dc (5-pole) 30 Vac/dc (8-pole)
Max. operating current:	4 A (5-pole) 2 A (8-pole)
Protection degree:	IP67 acc. to EN 60529
Ambient temperature:	-25°C ... +85°C
Wire cross-sections:	0.25 mm <sup>2</sup> (23 AWG) ... 0.5 mm <sup>2</sup> (20 AWG)
Tightening torque of the ring:	0.6 ... 0.8 Nm

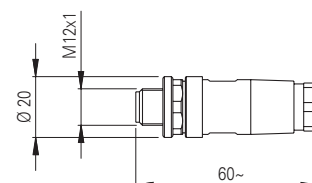

Article	Description	no. of poles
VF CCMP5DM04	Field wireable M12 male connector, straight, for Ø 4 ... Ø 6.5 mm multipolar cables	5
VF CCMP8DM04	Field wireable M12 male connector, straight, for Ø 4 ... Ø 7 mm multipolar cables	8

**ATTENTION:** always disconnect the power supply before removing the connector. The connector is not suitable for separation of electrical loads.

## Series connection with Y-shaped M12 connectors

To facilitate and simplify the series wiring of the safety devices, a variety of accessories designed specifically for this purpose are available. With the help of the proven M12 round connector, safety equipment of Category 4, SIL 3 and PL e with up to 32 elements connected in series is possible. All of which is possible without the risk of connection errors and with a high IP67 protection degree.

The safety circuits consist of a 24 Vdc power supply unit, a number of extensions to the installed devices, Y connectors for branching out from the chain to each individual device and a terminating plug.

In addition to the power supply unit, a suitable safety module is used to assess the state of the safety outputs within the safety chain.

### Devices suitable for series connection

The series may consist both of devices that are identical to one another (homogeneous series) or that belong to different series (mixed series).

The following Pizzato Elettrica devices may be connected in series using the Y connectors:

- ST series RFID safety sensors: ST ●●31●M●, ST ●●71●M●.
- NG series RFID safety switches with lock: NG ●●●●●●●-K950, NG ●●●●●●●-K951, NG ●●●●●●●-K952.
- NS series RFID safety switches with lock: NS ●●●●●●●Q●.
- HX series safety hinge switches: HX BEE1-●●M.

### Electrical connection of the chain

Pin	Colour	Connection
1	Brown	A1 Supply input +24 Vdc
2	White	OS1 Safety output
3	Blue	A2 Supply input 0 V
4	Black	OS2 Safety output
5	Grey	I4 Solenoid activation input

**Note:** By activating/deactivating input I4, all switches of the NG and NS series in the chain simultaneously block/open all guards. Activation and deactivation of input I4 has no effect on the ST sensors and HX hinges in the chain.

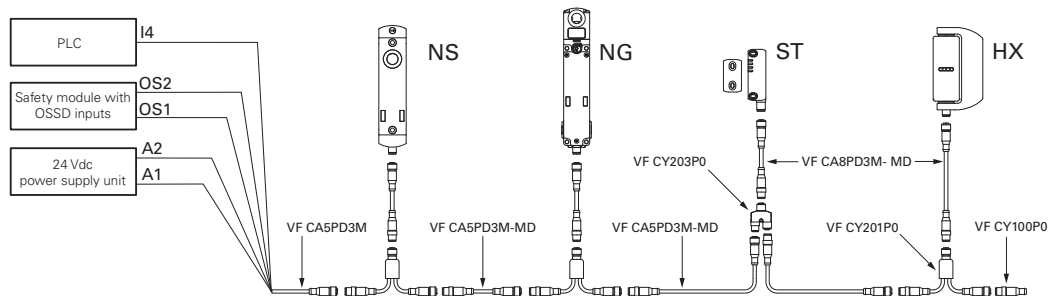

**Attention!** For proper operation of the devices connected in series via cables or Y connectors, it is necessary to pay particular attention to the voltage drop that occurs in the circuit. Pay particular attention to the currents and cross-sections/lengths of the used cables to ensure that the supply voltage of the components at the end of the series connection remains within the specified limit values during effective operation.

## M12 extension cables



### Features:

- Polyurethane connector body
- Class 6 copper conductors acc. to IEC 60228
- Gold-plated contacts
- Anti-vibration self-locking ring nut
- High flexibility cable with oil resistant PVC sheath suitable to be used in drag chains, acc. to IEC 60332-1-2

Max. operating voltage:	250 Vac / 300 Vdc (5-pole) 30 Vac / 36 Vdc (8-pole)
Max. operating current:	4 A (5-pole), 2 A (8-pole)
Protection degree:	IP67 acc. to EN 60529 IP69K acc. to ISO 2653 (Protect the cables from direct high-pressure and high-temperature jets)
Ambient temperature:	-25°C ... +80°C for fixed installation -15°C ... +80°C for mobile installation
Wire cross-sections:	0.5 mm <sup>2</sup> (20 AWG) (5-pole) 0.25 mm <sup>2</sup> (23 AWG) (8-pole)
Minimum bending radius:	> cable diameter x 15
Tightening torque of the ring:	0.6 ... 0.8 Nm

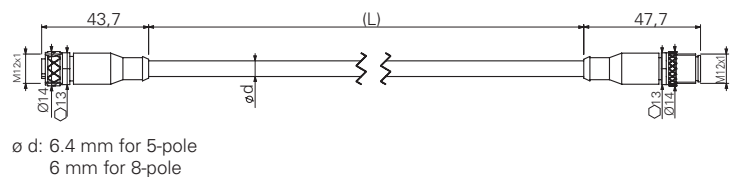

## Code structure

### VF CA5PD3M-MD

No. of poles	5 poles	8 poles	Connection type	M M12x1
Cable sheath	P PVC		Cable length (L)	3 3 metres (standard) 5 5 metres (standard) 10 10 metres (standard) Other lengths on request.
Connector type	D straight			

## Pin assignment

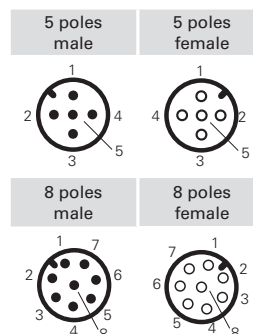

## Stock items

VF CA5PD3M-MD
VF CA5PD5M-MD
VF CA5PD10M-MD
VF CA8PD3M-MD
VF CA8PD5M-MD
VF CA8PD10M-MD

**Attention!** For items not in stock the minimum order quantity is 100 pcs.

**ATTENTION:** always disconnect the power supply before removing the connector. The connector is not suitable for separation of electrical loads.

All values in the drawings are in mm

→ The 2D and 3D files are available at [www.pizzato.com](http://www.pizzato.com)

## M12 connectors, Y-shaped, for series connections



Article	Description
VF CY201P0	M12 connector, Y-shaped, for series connections with 150 mm cable length

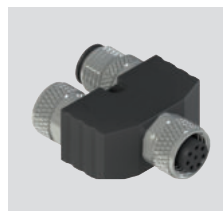

Article	Description
VF CY203P0	M12 connector, Y-shaped, for series connections without cable

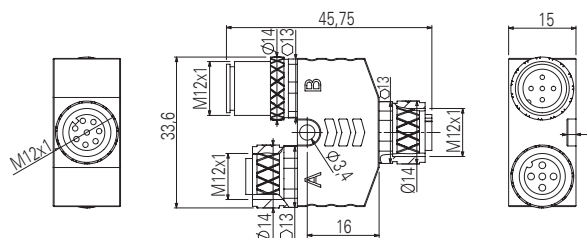
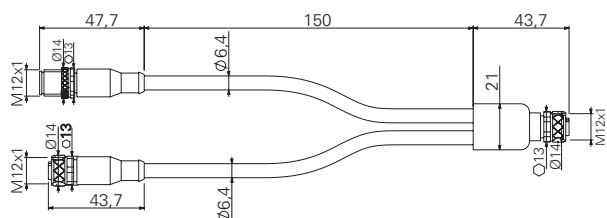

### Features:

- Polyurethane connector body
- Gold-plated contacts
- Anti-vibration self-locking ring nut
- Class 6 copper conductors acc. to IEC 60228
- High flexibility cable with oil resistant PVC sheath suitable to be used in drag chains, acc. to IEC 60332-1-2

Max. operating voltage:	30 Vac / 36 Vdc
Max. operating current:	4 A (5-pole) 2 A (8-pole)
Protection degree:	IP67 acc. to EN 60529
Ambient temperature:	-25°C ... +80°C for fixed installation -15°C ... +80°C for mobile installation
Wire cross-sections:	0.5 mm <sup>2</sup> (20 AWG)
Minimum bending radius:	> cable diameter x 15
Tightening torque of the ring:	0.6 ... 0.8 Nm

### Internal block diagram, Y-shaped connector

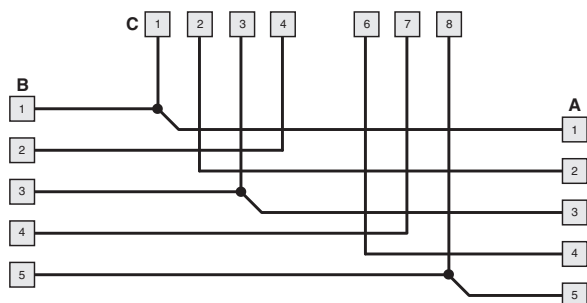

### Pin assignment

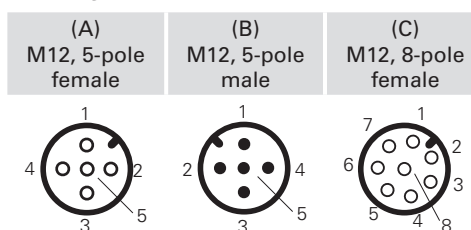

**IMPORTANT:** When used in safety applications, the Y connectors must be installed in a location that is not directly accessible, so as to avoid shocks or tampering.

## M12 terminating plugs for series connections



### Features:

- Polyurethane connector body
- Gold-plated contacts
- Anti-vibration self-locking ring nut

Max. operating voltage:	250 Vac / 300 Vdc
Max. operating current:	4 A
Protection degree:	IP67 acc. to EN 60529
Tightening torque of the ring:	0.6 ... 0.8 Nm

### Internal block diagram of the terminating plug

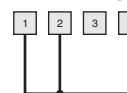

### Pin assignment

4-pole  
male

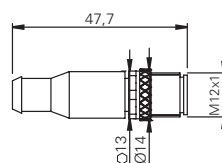
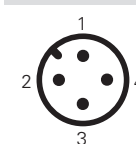

Article	Description
VF CY100P0	M12 terminating plugs for series connections, 4-pole

**ATTENTION:** always disconnect the power supply before removing the connector. The connector is not suitable for separation of electrical loads.

All values in the drawings are in mm

→ The 2D and 3D files are available at [www.pizzato.com](http://www.pizzato.com)

## M23 male connectors for panel mounting



## Features:

- Threaded connection M20 for installation on switches with M20 cable entry (for example: FG series and NG series)
- Nickel-plated metal connector body
- Gold-plated contacts
- 12-pole or 19-pole versions
- Wires with pre-insulated ferrules
- Directly installable on the device, these ensure quick replacement, reducing machine down time

Max. operating voltage:	250 Vac (12-pole) 100 Vac (19-pole)
Max. operating current:	3 A
Protection degree:	IP67 acc. to EN 60529 IP69K acc. to ISO 20653
Ambient temperature:	-25°C ... +80°C
Tightening torque:	1 ... 1.5 Nm
Wire cross-section:	0.34 mm <sup>2</sup> (22 AWG)
Contact type:	gold-plated

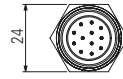

## Pin assignment

## 12 poles

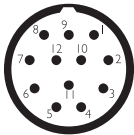

## 19-pole

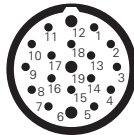

Pin	Colour	Pin	Colour	Pin	Colour
1	White	1	White	13	White-Green
2	Brown	2	Brown	14	Brown-Green
3	Green	3	Green	15	White-Yellow
4	Yellow	4	Yellow	16	Yellow-Brown
5	Grey	5	Grey	17	White-Grey
6	Pink	6	Pink	18	Grey-Brown
7	Blue	7	Blue	19	White-Pink
8	Red	8	Red		
9	Black	9	Black		
10	Purple	10	Purple		
11	Grey-Pink	11	Grey-Pink		
12	Red-Blue	12	Red-Blue		

## Code structure

**Attention!** The feasibility of a code number does not mean the effective availability of a product. Please contact our sales office.

## VF CNM12MT-L10

## Body material

**M** metal

## No. of poles

**12** 12 poles

**19** 19-pole

## Wire length (L)

**L10** 10 cm

**L16** 16 cm

## Note:

For applications with NG series switches, use connectors with L10 wire length.  
For applications with FG series switches, use connectors with L16 wire length.

**ATTENTION:** always disconnect the power supply before removing the connector. The connector is not suitable for separation of electrical loads.

All values in the drawings are in mm

→ The 2D and 3D files are available at [www.pizzato.com](http://www.pizzato.com)



## M23 female connectors for panel mounting

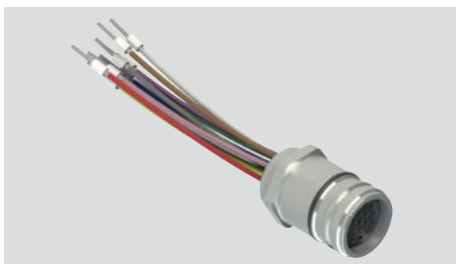

### Features:

- Threaded connection M20
- Nickel-plated metal connector body
- Gold-plated contacts
- 12-pole or 19-pole versions
- Wires with pre-insulated ferrules
- Directly installable on the device, these ensure quick replacement, reducing machine down time

Max. operating voltage:	250 Vac (12-pole) 100 Vac (19-pole)
Max. operating current:	3 A
Protection degree:	IP67 acc. to EN 60529 IP69K acc. to ISO 20653
Ambient temperature:	-25°C ... +80°C
Tightening torque:	1 ... 1.5 Nm
Wire cross-section:	0.34 mm <sup>2</sup> (22 AWG)
Contact type:	gold-plated

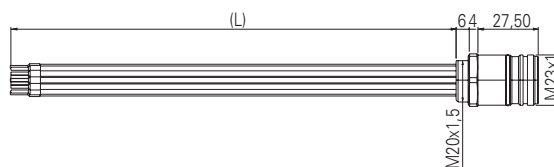

### Pin assignment

#### 12 poles

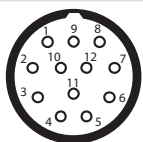

#### 19-pole

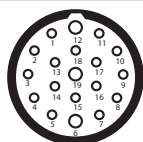

Pin	Colour	Pin	Colour	Pin	Colour
1	White	1	White	13	White-Green
2	Brown	2	Brown	14	Brown-Green
3	Green	3	Green	15	White-Yellow
4	Yellow	4	Yellow	16	Yellow-Brown
5	Grey	5	Grey	17	White-Grey
6	Pink	6	Pink	18	Grey-Brown
7	Blue	7	Blue	19	White-Pink
8	Red	8	Red		
9	Black	9	Black		
10	Purple	10	Purple		
11	Grey-Pink	11	Grey-Pink		
12	Red-Blue	12	Red-Blue		

### Code structure

**Attention!** The feasibility of a code number does not mean the effective availability of a product. Please contact our sales office.

## VF CPM12MT-L10

Body material	Wire length (L)
<b>M</b> metal	<b>L10</b> 10 cm
No. of poles	<b>L20</b> 20 cm
<b>12</b> 12 poles	
<b>19</b> 19-pole	

**ATTENTION:** always disconnect the power supply before removing the connector. The connector is not suitable for separation of electrical loads.

All values in the drawings are in mm

→ The 2D and 3D files are available at [www.pizzato.com](http://www.pizzato.com)

## M23 female connectors with cable



## Features:

- Polyurethane connector body
- Class 5 tin-plated copper conductors acc. to IEC 60228 (12-pole)
- Class 5 tin-plated copper conductors acc. to IEC 60228 (19-pole)
- Gold-plated contacts
- Anti-vibration self-locking ring nut
- Cable with PVC sheath acc. to IEC 60332-1-2 (flame retardant)

Max. operating voltage:	160 Vac (12-pole) 63 Vac (19-pole)
Maximum operating current with 12 poles:	5 A x 0.5 mm <sup>2</sup> (20 AWG), the currents are per conductor
Maximum operating current with 19 poles:	8 A x 0.75 mm <sup>2</sup> + 4 A x 0.34 mm <sup>2</sup> (22 AWG), the currents are per conductor
Protection degree:	IP67 acc. to EN 60529 IP69K acc. to ISO 20653 (Protect the cables from direct high-pressure and high-temperature jets)
Ambient temperature:	-5°C ... +70°C
Wire cross-section:	12x0,5 mm <sup>2</sup> (12-pole) 17x0.34 mm <sup>2</sup> + 2x0.75 mm <sup>2</sup> (19-pole)
Minimum bending radius:	> cable diameter x 15
Tightening torque of the ring:	1 ... 1.5 Nm

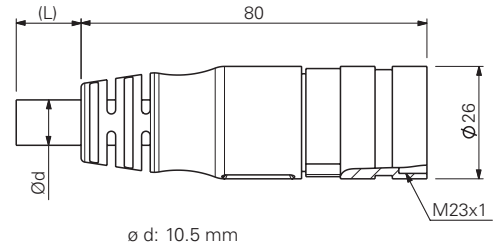

## Pin assignment

## 12 poles



## 19-pole

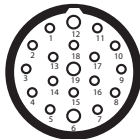

Pin	Colour	Pin	Colour	Pin	Colour
1	White	1	White	13	White-Green
2	Brown	2	Brown	14	Brown-Green
3	Green	3	Green	15	White-Yellow
4	Yellow	4	Yellow	16	Yellow-Brown
5	Grey	5	Grey	17	White-Grey
6	Pink	6	Pink	18	Grey-Brown
7	Blue	7	Blue	19	White-Pink
8	Red	8	Red		
9	Black	9	Black		
10	Purple	10	Purple		
11	Grey-Pink	11	Grey-Pink		
12	Red-Blue	12	Red-Blue		

## Code structure

**Attention!** The feasibility of a code number does not mean the effective availability of a product. Please contact our sales office.

## VF CA12PD20S

## No. of poles

**12** 12 poles

**19** 19-pole

## Cable sheath

**P** PVC

## Connector type

**D** straight

## Connection type

**S** M23x1

## Cable length (L)

**5** 5 metres

**10** 10 metres

**20** 20 metres

**30** 30 metres

Other lengths on request.

## Stock items

VF CA12PD10S

VF CA12PD20S

VF CA12PD30S

VF CA19PD5S

VF CA19PD10S

VF CA19PD20S

VF CA19PD30S

**Attention!** For items not in stock the minimum order quantity is 50 pcs.

**ATTENTION:** always disconnect the power supply before removing the connector. The connector is not suitable for separation of electrical loads.

All values in the drawings are in mm

→ The 2D and 3D files are available at [www.pizzato.com](http://www.pizzato.com)

## Field wireable M23 female connectors



### Features:

- Nickel-plated metal connector body
- Gold-plated contacts
- 12-pole or 19-pole versions

Max. operating voltage:	250 Vac (12-pole) 100 Vac (19-pole)
Max. operating current:	8 A
Protection degree:	IP67 acc. to EN 60529 IP69K acc. to ISO 20653
Ambient temperature:	-40°C ... +125°C
Tightening torque of the ring:	1 ... 1.5 Nm
Pollution degree:	3

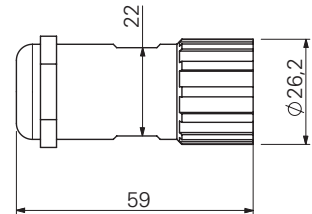

### Pin configuration

#### 12 poles

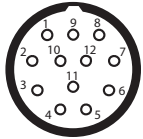

clockwise numbering

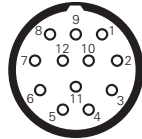

counterclockwise numbering

#### 19-pole

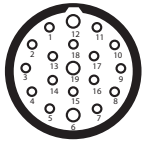

clockwise numbering



Article	Description
VF AC2205	Mounting key

**Note:** Article required for opening and wiring of connector.

### Code structure

**Attention!** The feasibility of a code number does not mean the effective availability of a product. Please contact our sales office.

## VF CBSM12TC07

#### Connection type

**S** M23x1

#### Body material

**M** metal

#### No. of poles

**12** 12 poles

**19** 19-pole

#### Connector type

**T** clockwise numbering (standard)

**D** counterclockwise numbering

#### Cable diameter

**07** Ø 7 ... 12 mm

#### Pin connection type

**C** crimp connection (standard) 0.34 ... 1 mm<sup>2</sup>

**S** solder connection 0.34 ... 1 mm<sup>2</sup>

**Note:** Use appropriate crimp pliers for crimp connections (e.g., Knipex, article number 97 52 63).

#### Stock items

VF CBSM12TC07

VF CBSM19TC07

VF CBSM12TS07

**ATTENTION:** always disconnect the power supply before removing the connector. The connector is not suitable for separation of electrical loads.

All values in the drawings are in mm

→ The 2D and 3D files are available at [www.pizzato.com](http://www.pizzato.com)

## M23 extension cables with male and female connector



### Features:

- Polyurethane connector body
- Class 5 tin-plated copper conductors acc. to IEC 60228
- Gold-plated contacts
- Anti-vibration self-locking ring nut
- Cable with PVC sheath acc. to IEC 60332-1-2 (flame retardant)

Max. operating voltage:	63 Vac
Maximum operating current with 19 poles:	8 A x 0.75 mm <sup>2</sup> + 4 A x 0.34 mm <sup>2</sup> (22 AWG), the currents are per conductor
Protection degree:	IP67 acc. to EN 60529 IP69K acc. to ISO 20653 (Protect the cables from direct high-pressure and high-temperature jets)
Ambient temperature:	-5°C ... +70°C
Wire cross-section:	17x0.34 mm <sup>2</sup> + 2x0.75 mm <sup>2</sup>
Minimum bending radius:	> cable diameter x 15
Tightening torque of the ring:	1 ... 1.5 Nm

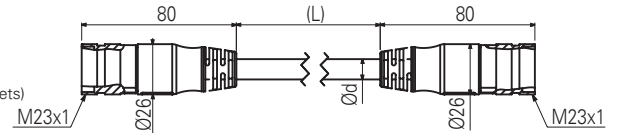

### Pin assignment

19-pole male

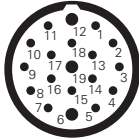

19-pole female

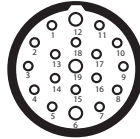

### Code structure

**Attention!** The feasibility of a code number does not mean the effective availability of a product. Please contact our sales office.

## VF CA19PD5S-SD

No. of poles	19	19-pole	Connection type	S	M23x1
Cable sheath	P	PVC	Cable length (L)	5	5 metres
Connector type	D	straight	10	10 metres	
			20	20 metres	

Other lengths on request.

**ATTENTION:** always disconnect the power supply before removing the connector. The connector is not suitable for separation of electrical loads.

All values in the drawings are in mm

→ The 2D and 3D files are available at [www.pizzato.com](http://www.pizzato.com)

## M8 female connectors with cable



### Features:

- Polyurethane connector body
- Class 6 copper conductors acc. to IEC 60228
- Gold-plated contacts
- Anti-vibration self-locking ring nut
- High flexibility cable with oil resistant PVC or PUR sheath suitable to be used in drag chains, acc. to IEC 60332-1-2

Max. operating voltage:	60 Vac / 75 Vdc
Max. operating current:	4 A
Protection degree:	IP67 acc. to EN 60529 IP69K acc. to ISO 20653 (Protect the cables from direct high-pressure and high-temperature jets)
Ambient temperature:	-25°C ... +80°C for fixed installation -15°C ... +80°C for mobile installation
Wire cross-sections:	0.25 mm <sup>2</sup> (23 AWG)
Minimum bending radius:	> cable diameter x 15
Tightening torque of the ring:	0.3 ... 0.5 Nm

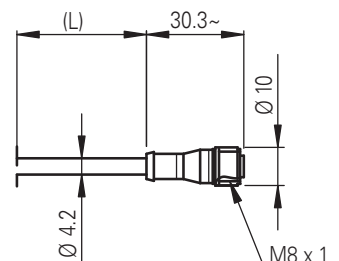

### Pin assignment

4 poles

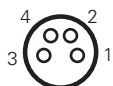

Pin	Colour
1	Brown
2	White
3	Blue
4	Black

### Code structure

**Attention!** The feasibility of a code number does not mean the effective availability of a product. Please contact our sales office.

## VF CA4PD3K

No. of poles	<b>4</b> 4 poles	Connection type	<b>K</b> M8x1
Cable sheath	<b>P</b> PVC (standard) <b>U</b> PUR	Cable length (L)	<b>1</b> 1 metre <b>2</b> 2 metres <b>3</b> 3 metres (standard) <b>4</b> 4 metres <b>5</b> 5 metres (standard) ... <b>10</b> 10 metres
Connector type	<b>D</b> straight	Other lengths on request.	

### Stock items

VF CA4PD3K  
VF CA4PD5K

### Attention!

For items not in stock the minimum order quantity is 100 pcs.

**ATTENTION:** always disconnect the power supply before removing the connector. The connector is not suitable for separation of electrical loads.

All values in the drawings are in mm

→ The 2D and 3D files are available at [www.pizzato.com](http://www.pizzato.com)

## Strain relief cable glands

Packs of **10 pcs.**

This particular design ensures high resistance to traction of the cable glands. All cable glands are also suitable for a wide range of cable diameters.

Suitable for circular cross-section cables only.

**Features:**

Body and ring material: technopolymer without halogen

Protection degree: IP67 acc. to EN 60529

Tightening torque: 3 ... 4 Nm (PG 13.5/M20)

2 ... 2.5 Nm (PG 11/M16)

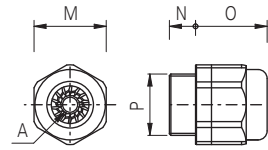

	Article	Description	A	⬡M	N	O	P
Metric threads	VF PAM25C7N	M25x1.5 cable gland for one cable Ø 10 ... 17 mm	⊙	33	10	31	M25x1.5
	VF PAM20C6N	M20x1.5 cable gland for one cable Ø 6 ... 12 mm	⊙	24	9	24	M20x1.5
	VF PAM20C5N	M20x1.5 cable gland for one cable from Ø 5 ... 10 mm	⊙	24	9	24	M20x1.5
	VF PAM20C3N	M20x1.5 cable gland for one cable Ø 3 ... 7 mm	⊙	24	9	24	M20x1.5
	VF PAM16C5N	M16x1.5 cable gland for one cable Ø 5 ... 10 mm	⊙	22	7.5	23	M16x1.5
	VF PAM16C4N	M16x1.5 cable gland for one cable Ø 4 ... 8 mm	⊙	22	7.5	23	M16x1.5
	VF PAM16C3N	M16x1.5 cable gland for one cable Ø 3 ... 7 mm	⊙	22	7.5	23	M16x1.5
	VF PAM20CBN	M20x1.5 multi-hole cable gland for 2 cables Ø 3 ... 5 mm	⊙	24	9	23	M20x1.5
	VF PAM20CDN	M20x1.5 multi-hole cable gland for 3 cables Ø 1 ... 4 mm	⊙	24	9	23	M20x1.5
	VF PAM20CEN	M20x1.5 multi-hole cable gland for 3 cables Ø 3 ... 5 mm	⊙	24	9	23	M20x1.5
	VF PAM20CFN	M20x1.5 multi-hole cable gland for 4 cables Ø 1 ... 4 mm	⊙	22	9	23	M20x1.5
PG threads	VF PAP13C6N	PG 13.5 cable gland for one cable from Ø 6 ... 12 mm	⊙	24	9	24	PG 13.5
	VF PAP13C5N	PG 13.5 cable gland for one cable from Ø 5 ... 10 mm	⊙	24	9	24	PG 13.5
	VF PAP13C3N	PG 13.5 cable gland for one cable from Ø 3 ... 7 mm	⊙	24	9	24	PG 13.5
	VF PAP11C5N	PG 11 cable gland for one cable from Ø 5 ... 10 mm	⊙	22	7.5	23	PG 11
	VF PAP11C4N	PG 11 cable gland for one cable from Ø 4 ... 8 mm	⊙	22	7.5	23	PG 11
	VF PAP11C3N	PG 11 cable gland for one cable from Ø 3 ... 7 mm	⊙	22	7.5	23	PG 11

## Thread adapters

Packs of **100 pcs.**

Thread adapters make it possible to fulfil requests for switches with a different thread to those generally found in stock. This means it is possible to offer customers a single product type with various threaded connections, while only having to stock the product itself and many kinds of adapters.

**Features:**

Body material: glass fibre reinforced technopolymer

Tightening torque: 3 ... 4 Nm

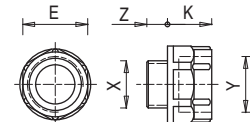

Article	Description	X	Y	Z	K	⬡E
VF ADPG13-PG11	Adapter from PG 13.5 to PG 11	PG 13.5	PG 11	9	12	22
VF ADPG13-M20	Adapter from PG 13.5 to M20x1.5	PG 13.5	M20x1.5	9	14	24
VF ADPG13-1/2NPT	Adapter from PG 13.5 to 1/2 NPT	PG 13.5	1/2 NPT	9	14	24
VF ADPG11-1/2NPT	Adapter from PG 11 to 1/2 NPT	PG 11	1/2 NPT	7	14	24
VF ADPG11-PG13	Adapter from PG 11 to PG 13.5	PG 11	PG 13.5	7	14	24
VF ADM20-1/2NPT	Adapter from M20x1.5 to 1/2 NPT	M20x1.5	1/2 NPT	9	14	24

## Protection caps

Packs of **10 pcs.****Features:**

Body material: technopolymer, self-extinguishing  
 Protection degree: IP67 acc. to EN 60529  
 IP69K acc. to ISO 20653  
 Tightening torque: 1.2 ... 1.6 Nm  
 Cross-recessed screw: PH3

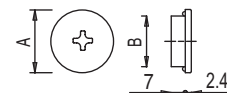

Article	Description	A	B
VF PTM20	Protection cap M20x1.5	24	M20x1.5
VF PTG13.5	Protection cap PG13.5	24	PG 13.5

## Threaded nuts

Packs of **10 pcs.****Features:**

Tightening torque: 1.2 ... 2 Nm

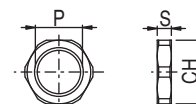

	Article	Description	S	CH	P
Plastic	VF DFPM25	M25x1.5 threaded technopolymer nut	6	32	M25x1.5
	VF DFPM20	M20x1.5 threaded technopolymer nut	6	27	M20x1.5
	VF DFPM16	M16x1.5 threaded technopolymer nut	5	22	M16x1.5
	VF DFPP13	PG13.5 threaded technopolymer nut	6	27	PG 13.5
Metal	VF DFMM20	M20x1.5 threaded nut in nickel-plated brass	3	23	M20x1.5

## Chock plugs

Packs of **100 pcs.****Features:**

Body material: technopolymer  
 Protection degree: IP54 acc. to EN 60529  
 Tightening torque: 0.8 ... 1 Nm

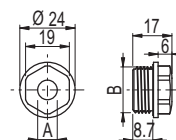

**Note:** Use a socket wrench for tightening.

Article	Description	A	B
VF PFM20C8N	Chock plug for one cable Ø 8 ... 12 mm, threaded, M20x1.5	7.5	M20x1.5
VF PFM20C4N	Chock plug for one cable Ø 4 ... 8 mm, threaded, M20x1.5	3.5	M20x1.5

### Tampering protection for M12 connectors

Packs of 10 pcs.

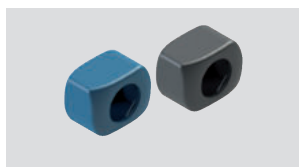

#### Features:

These tampering protections are composed of two identical snap-on shells. They are applied to the device connectors, thereby making them inaccessible. The shells can only be removed by breaking them. Thus, any attempt to tamper with them will be immediately evident.

The protection can be installed quickly and easily by pressing the two shells lightly into place.

The protections are suitable for all devices with an M12 connector (e.g. NS, ST, SR series) but they can also be used for junctions between cables with male - female connectors.

A version made of detectable plastic is available for the food industry, and it can easily be detected during the process using common optical vision technologies, X-rays or metal detectors.

#### Installation:

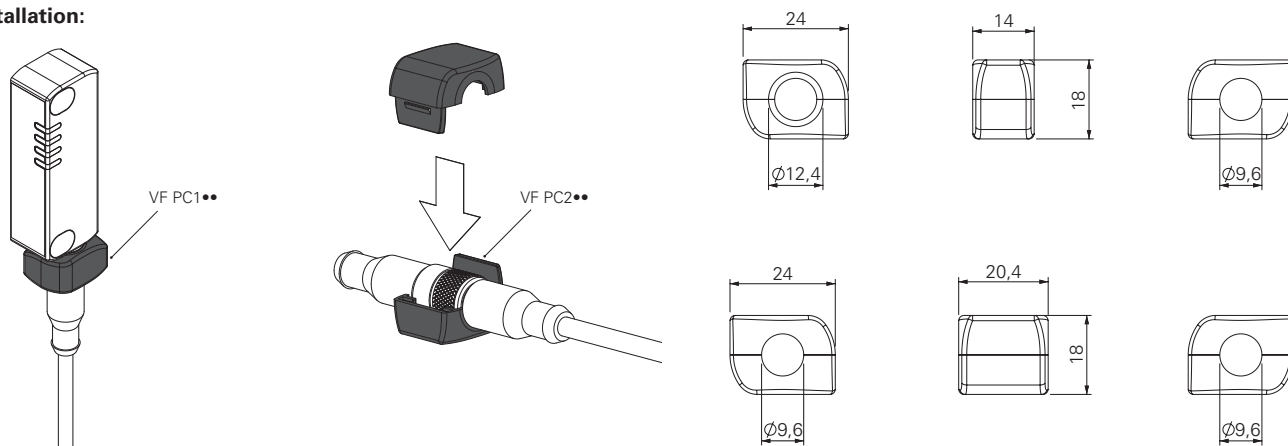

Article	Description	Colour / material
VF PC1A9	Tamper-proof protection for device-side connector	● Grey technopolymer
VF PC2A9	Tamper-proof protection for male - female connector	● Grey technopolymer
VF PC1B6	Tamper-proof protection for device-side connector	● Blue detectable technopolymer
VF PC2B6	Tamper-proof protection for male - female connector	● Blue detectable technopolymer

### Door holding magnets



Article	Description
SM H9ZF	Door holding magnet (holding force 40 N)
SM H9ZQ	Door holding magnet (holding force 40 N, opposite polarity to SM H9ZF)

Holding magnets for use on machinery doors. The magnets are sealed inside a plastic cover and will not rust even in damp environments.

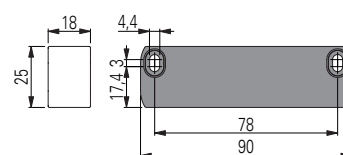



## LED signalling lights

Packs of 5 pcs.



These signalling lights with high luminosity LEDs are used for signalling that an electric contact has changed its state inside the switch. They can be installed on switches of the FL, FX, FZ, FW, FG, FY, NG or FS series by screwing them on one of the conduit entries not used for electric cables. They can be used for many different purposes: for example, to signal, from a distance, whether the switch has been actuated; whether the guard has closed correctly; or whether the guard is locked or unlocked. The inner part can rotate in such a way that it can be wired and screwed on the switch without any risk of twisting the wires.

**Features:**

Protection degree:

IP67 acc. to EN 60529

Ambient temperature:

IP69K acc. to ISO 20653

Operating voltage  $U_n$ :

-25°C ... +70°C

24 Vac/dc (10 mA)

120 Vac (20 mA)

230 Vac (20 mA)

Tolerance on the supply voltages:

 $\pm 15\%$  of  $U_n$ 

Operating current:

10 mA

Connection system:

PUSH-IN spring type

Cross-section of rigid/flexible wires w. wire-end sleeve:

min. 1 x 0.34 mm<sup>2</sup> (1 x AWG 24)max. 1 x 1.5 mm<sup>2</sup> (1 x AWG 16)

Wire cross-section with pre-insulated wire-end sleeve:

min. 1 x 0.34 mm<sup>2</sup> (1 x AWG 24)max. 1 x 0.75 mm<sup>2</sup> (1 x AWG 18)

Tightening torque:

1.2 ... 2 Nm

Wire stripping length (x):

min.: 8 mm

max.: 12 mm

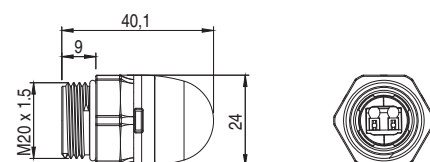
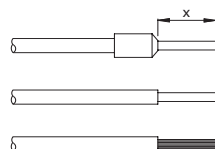

## Application examples

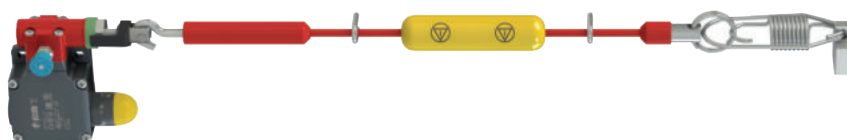

Status indicator for safety rope switches

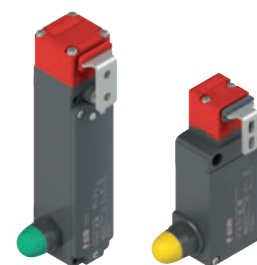

Indication of unlocked door

## Code structure

**Attention!** The feasibility of a code number does not mean the effective availability of a product. Please contact our sales office

## VF SL1A3PA1

## Operating voltage

<b>1</b>	24 Vac/dc
<b>3</b>	120 Vac
<b>4</b>	230 Vac

## Body design

<b>A</b>	Total height 40 mm, spherical lens, threading M20x1.5 mm
----------	--

## Stock items

VF SL1A3PA1
VF SL1A5PA1

## Type of light source

<b>A</b>	Standard LED with continuous light
----------	------------------------------------

## Connection type

<b>P</b>	PUSH-IN terminal strip
----------	------------------------

## Lens colour

<b>2</b>	White
<b>3</b>	Red
<b>4</b>	Green
<b>5</b>	Yellow

All values in the drawings are in mm

→ The 2D and 3D files are available at [www.pizzato.com](http://www.pizzato.com)

## Fixing plates



Metal fixing plate, for fixing rope switches on the ceiling.  
The plate is provided with bore holes for fastening switches of the FD, FL, FC, FP, FR, FM, FZ, FX, FK series. It is supplied without screws.

Article	Description
VF SFP2	Ceiling fixing plate

## Fixing plates



Fixing plate (complete with fastening screws) provided with long slots for adjusting the operating point.  
Each plate is provided with two pairs of mounting holes, one for standard switches and one for switches with reset device. The actuator thus always has the same actuating point.

Article	Description
VF SFP1	Fixing plate (FR series)
VF SFP3	Fixing plate (FX series)

## Torx safety screws

Packs of **10 pcs.**

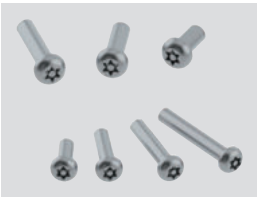

Pan head screws with Torx fitting and pin, stainless steel.  
Use a thread locker where required for applications acc. to EN ISO 14119.

Article	Description
VF VAM4X10BX-X	M4x10 screw, with Torx T20 fitting, AISI 304
VF VAM4X15BX-X	M4x15 screw, with Torx T20 fitting, AISI 304
VF VAM4X20BX-X	M4x20 screw, with Torx T20 fitting, AISI 304
VF VAM4X25BX-X	M4x25 screw, with Torx T20 fitting, AISI 304
VF VAM4X30BX-X	M4x30 screw, with Torx T20 fitting, AISI 304
VF VAM5X10BX-X	M5x10 screw, with Torx T25 fitting, AISI 304
VF VAM5X15BX-X	M5x15 screw, with Torx T25 fitting, AISI 304
VF VAM5X20BX-X	M5x20 screw, with Torx T25 fitting, AISI 304
VF VAM5X25BX-X	M5x25 screw, with Torx T25 fitting, AISI 304
VF VAM5X35BX-X	M5x35 screw, with Torx T25 fitting, AISI 304
VF VAM5X45BX-X	M5x45 screw, with Torx T25 fitting, AISI 304

## OneWay safety screws

Packs of **10 pcs.**



Pan head screws with OneWay fitting in stainless steel.  
This screw type cannot be removed or tampered with using common tools. Ideal for fixing safety device actuators in accordance with EN ISO 14119.

Article	Description
VF VAM4X10BW-X	M4x10 screw, with OneWay fitting, AISI 304
VF VAM4X15BW-X	M4x15 screw, with OneWay fitting, AISI 304
VF VAM4X20BW-X	M4x20 screw, with OneWay fitting, AISI 304
VF VAM4X25BW-X	M4x25 screw, with OneWay fitting, AISI 304
VF VAM5X10BW-X	M5x10 screw, with OneWay fitting, AISI 304
VF VAM5X15BW-X	M5x15 screw, with OneWay fitting, AISI 304
VF VAM5X20BW-X	M5x20 screw, with OneWay fitting, AISI 304
VF VAM5X25BW-X	M5x25 screw, with OneWay fitting, AISI 304

## Bits for Torx safety screws

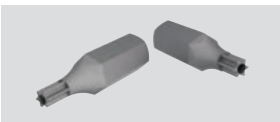

Bits for Torx safety screws with pin, with 1/4" hexagonal connection.

Article	Description
VF VAIT1T20	Bits for M4 screws with Torx T20 fitting
VF VAIT1T25	Bits for M5 screws with Torx T25 fitting
VF VAIT1T30	Bits for M6 screws with Torx T30 fitting

## Junction box for series connection of up to 4 devices

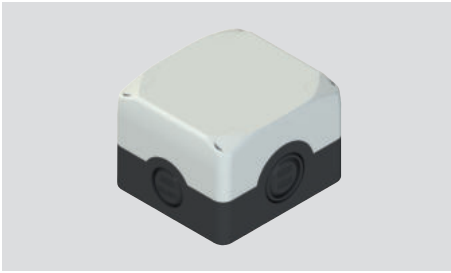

This accessory allows easy and precise series connection of up to 4 devices. Thanks to the numbered terminals and to the internal circuit, it is sufficient to connect the conductors in the slots provided with the practical and fast PUSH-IN spring connections. Thanks to the four internal microswitches, it is possible to easily and immediately direct the device signalling outputs (open or closed, locked or unlocked) to one of the four available auxiliary channels and then manage the information independently for each channel through a PLC.

### Features:

- Material:** Self-extinguishing shock-proof polycarbonate with double insulation, UV-resistant and glass fibre reinforced
- Material of the screws:** Stainless steel
- Protection degree:** IP67 acc. to EN 60529, IP69K acc. to ISO 20653, with cable gland of equal or higher protection degree
- Conduit entries:** 2x M20 - 1/2 NPT knock-out side entries  
2x M20 - 1/2 NPT - M25 knock-out side entries  
2x M16 knock-out base entries
- Ambient temperature:** -40°C ... +80°C
- Tightening torque of the cover screws:** 1 ... 1.4 Nm
- Connection system:** PUSH-IN spring type
- Cross-section of rigid/flexible wires w. wire-end sleeve:** min. 1 x 0.34 mm<sup>2</sup> (1 x AWG 24)  
max. 1 x 1.5 mm<sup>2</sup> (1 x AWG 16)
- Wire cross-section with pre-insulated wire-end sleeve:** min. 1 x 0.34 mm<sup>2</sup> (1 x AWG 24)  
max. 1 x 0.75 mm<sup>2</sup> (1 x AWG 18)
- Wire stripping length (x):** min.: 8 mm  
max.: 12 mm



### Pin assignment

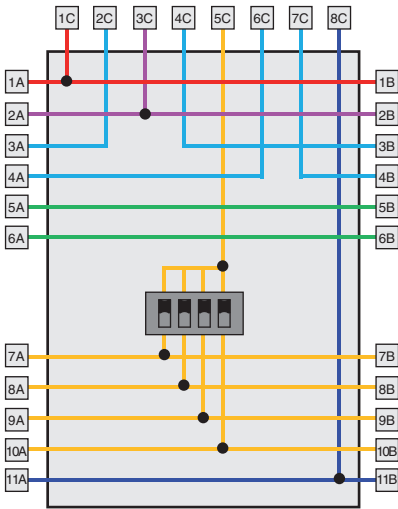

Article	Description
VF CY302P0	Junction box for series connection of up to 4 devices

Terminal box	Connection	Terminal box	Connection
1A / 1B	A1 Supply input +24 Vdc	1C	A1 Supply input +24 Vdc
2A / 2B	A2 Supply input 0 V	2C	OS1 Safety output
3A / 3B	OS1 / IS1 Safety output / safety input	3C	A2 Supply input 0 V
4A / 4B	OS2 / IS2 Safety output / safety input	4C	IS1 Safety input
5A / 5B	Auxiliary connection	5C	O3 Signalling output, actuator inserted
6A / 6B	Auxiliary connection	6C	O4 Signalling output, actuator inserted and locked
7A / 7B	OAU1 Auxiliary output Oaux1	7C	OS2 Safety output
8A / 8B	OAU2 Auxiliary output Oaux2	8C	IS2 Safety input
9A / 9B	OAU3 Auxiliary output Oaux3		
10A / 10B	OAU4 Auxiliary output Oaux4		
11A / 11B	I4 Solenoid activation input		

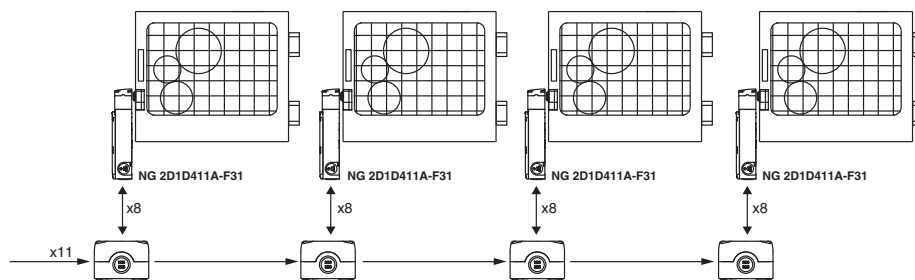

### Example of series connection of 4 NG series switches

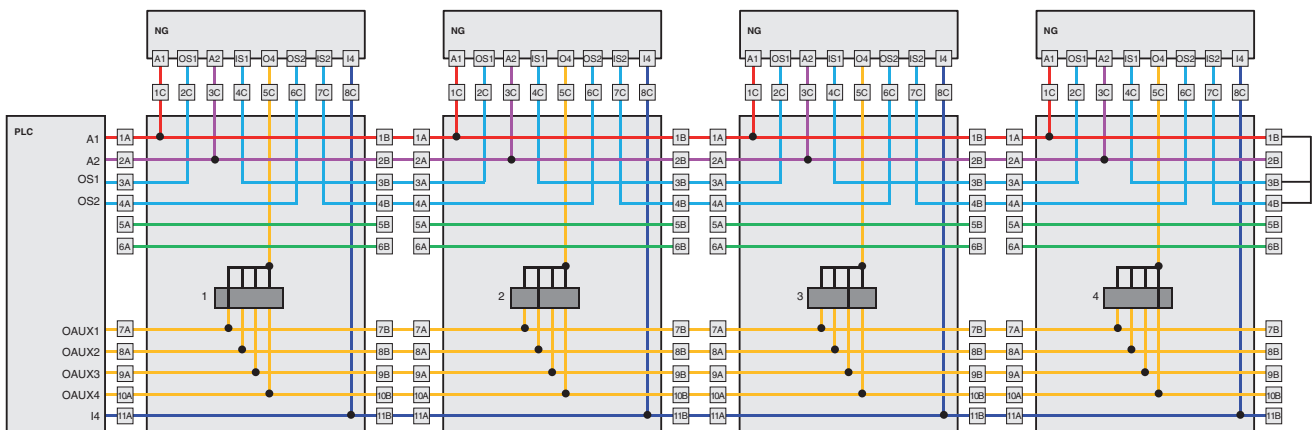

### Wiring diagram



### Installation of single switches with safety functions

- Use **only** switches with the symbol  (see figure on the side).
- Connect the safety circuit to **the NC normally closed contacts (11-12, 21-22 or 31-32)**.
- **The NO normally open contacts (13-14, 23-24, 33-34)** should be used **only for signalling**; these contacts are not to be connected with the safety circuit. However, if two or more switches are used on the same guard, a connection can be established between the NO contacts and the safety circuit. In this case at least one of the two switches must have positive opening and a normally closed contact NC (11-12, 21-22 or 31-32) must be connected to the safety circuit.
- Actuate the switch **at least up to the positive opening travel** shown in the travel diagrams with symbol .
- The actuation system must be able to exert a force that is greater than the **positive opening force**, as specified in brackets below each article, next to the minimum force value.
- The device must be affixed in compliance with EN ISO 14119.

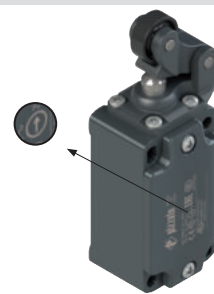

Whenever the machine guard is opened and during the whole opening travel, **the switch must be pressed directly** (fig. 1) **or through a rigid connection** (fig. 2).

Only in this way the positive opening of the normally closed NC contacts (11-12, 21-22, 31-32) is guaranteed.

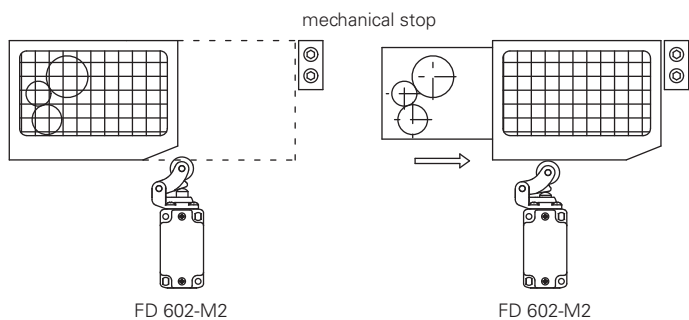

Fig.1

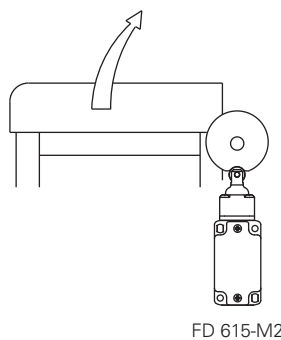

Fig.2

In safety applications with only one switch for each guard, the switches **must never be activated by a release** (fig. 3 and 4) **or through a non rigid connection** (i.e. by a spring).

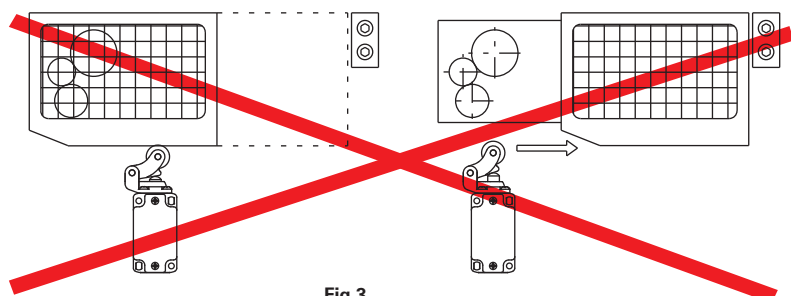

Fig.3

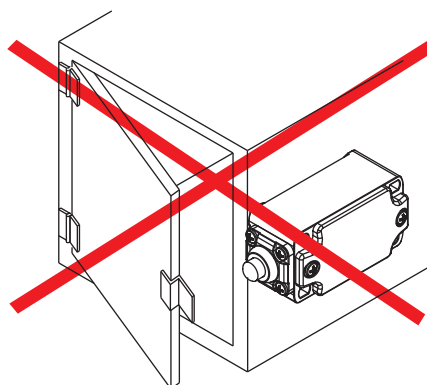
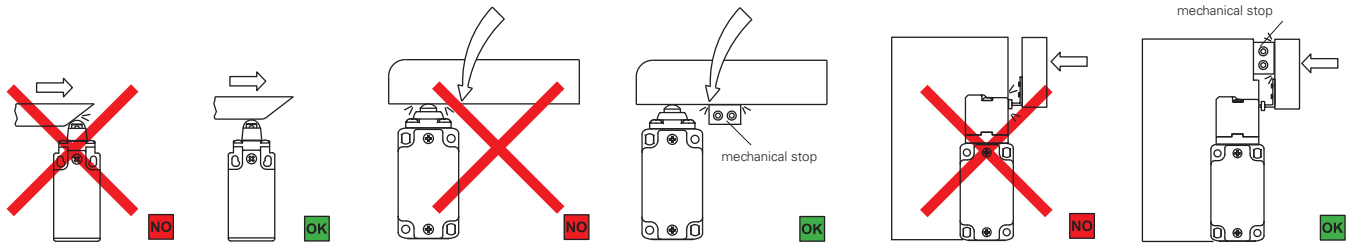

Fig.4

### Mechanical stop

Acc. to EN ISO 14119 paragraph 5.2 letter h) the position sensors must not be used as mechanical stop.



The actuator must not exceed the max. travel as indicated in the travel diagrams.

The guard must not use the switch head as a mechanical stop.

The actuator must not strike directly against the switch head.

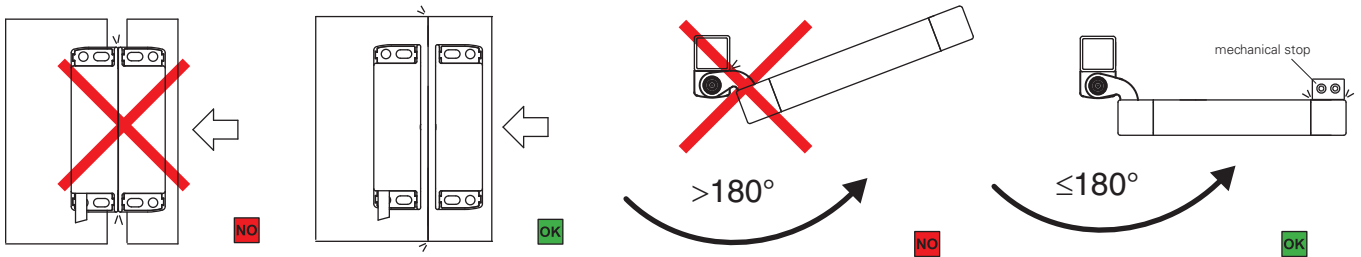

The actuator must not strike directly against the magnetic sensor.

The opening angle of safety hinge switch HP, HC and HX series must not exceed 180°.

### Actuation modes

Recommended application	Application to avoid This application is possible, but increased mechanical stress may shorten the operating life of the switch	Forbidden application

## Switches for heavy duty applications

## Maximum and minimum actuation speed - FD, FL, FP, FC series

## Roller lever - Type 1

$\varphi$	Vmax (m/s)	Vmin (mm/s) L	Vmin (mm/s) R
15°	2,5	9	0,07
30°	1,5	8	
45°	1	7	
60°	0,75	7	

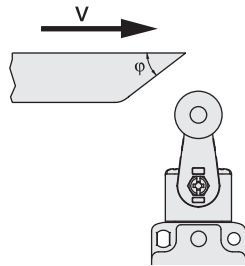

## Roller plunger - Type 2

$\varphi$	Vmax (m/s)	Vmin (mm/s) L	Vmin (mm/s) R
15°	1	4	0,04
30°	0,5	2	0,02
45°	0,3	1	0,01

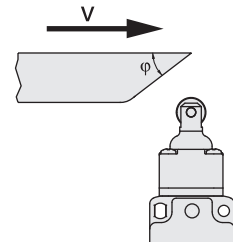

## Roller lever - Type 3

$\varphi$	Vmax (m/s)	Vmin (mm/s) L	Vmin (mm/s) R
15°	1	5	0,05
30°	0,5	2,5	0,025
45°	0,3	1,5	0,015

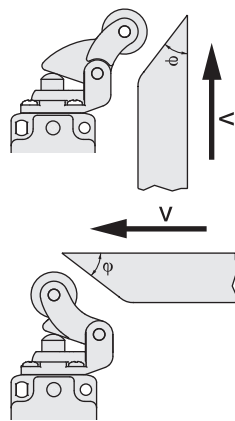

## Plunger - Type 4

Vmax (m/s)	Vmin (mm/s) L	Vmin (mm/s) R
0,5	1	0,01

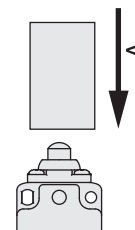

Contact type:

**R** = snap action  
**L** = slow action

## Tightening torques – FD, FP, FL, FC, FG, FY, FS, NG, NS series

- |  |                                |  |                |
|--|--------------------------------|--|----------------|
| 1 Cover screws   | 0.8 ... 1.2 Nm                 | 7 M5 fixing screws, body NS<br>(with washer) | 3 Nm           |
| 2 Head screws  | 0.8 ... 1.2 Nm                 | 8 Actuator screws VF KEY•••                  | 1.2 ... 1.6 Nm |
| 3 Lever screw  | 0.8 ... 1.2 Nm                 |  |                |
| 4 Protection caps<br>(conduit entry M20/PG13.5)<br>(conduit entry M16/PG11)            | 1.2 ... 1.6 Nm<br>1 ... 1.4 Nm |  |                |
| 5 Contact block screws   | 0.6 ... 0.8 Nm                 |  |                |
| 6 M5 fixing screws, body FD, FP, FL, FC, FG, FY,<br>FS, NG (with washer for FS series) | 2 ... 3 Nm                     |  |                |

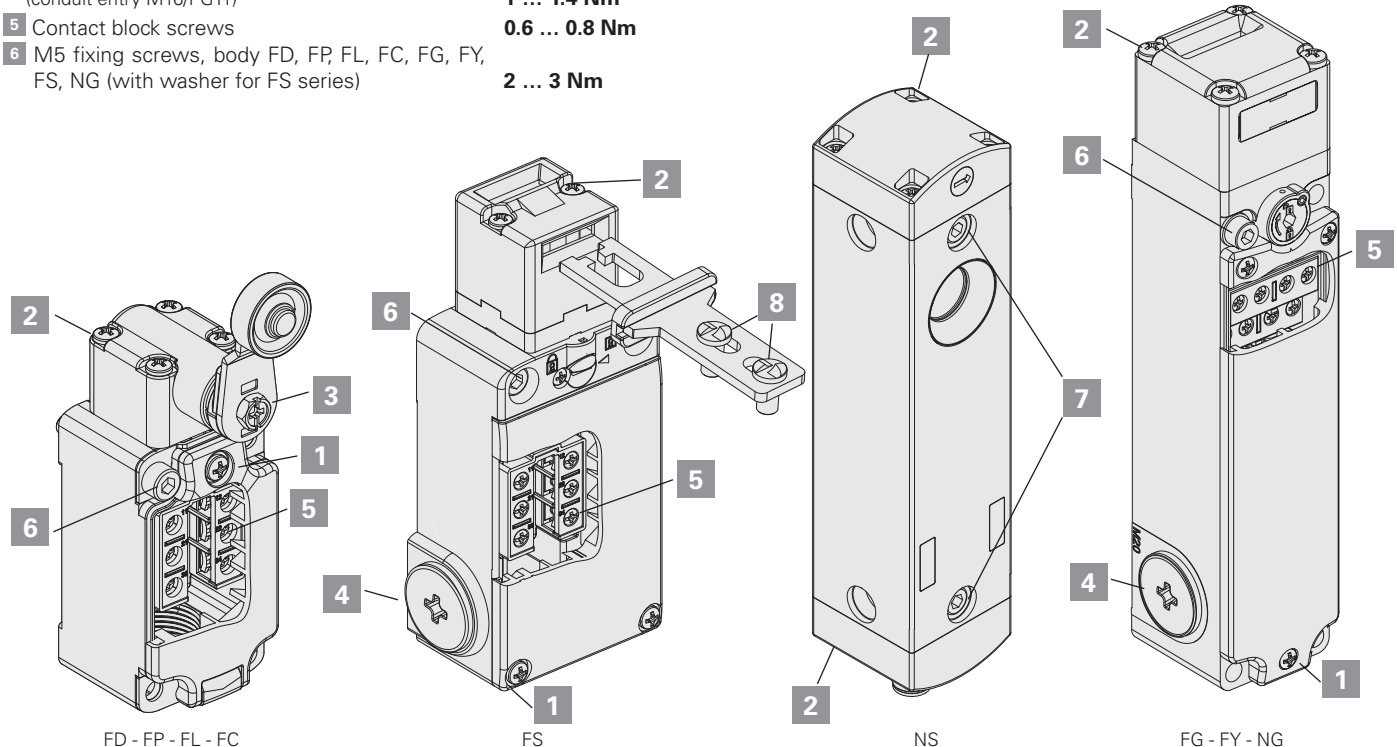

# FD, FP, FL, FC series switches for heavy duty applications

## Travel diagrams

Contact block	Group 1	Group 2	Group 3	Group 4	Group 5	Group 6 inverted contacts
2 2x(1NO-1NC) 						
3 1NO-1NC 						
5 1NO+1NC 						
6 1NO+1NC 			/			
7 1NO+1NC 			/			
9 2NC 			/			
10 2NO 						
11 2NC 			/		/	
12 2NO 			/			
13 2NC 			/			
14 2NC 			/			
15 2NO 			/			
16 2NC 	/	/	/		/	/
18 1NO+1NC 						
20 1NO+2NC 						
21 3NC 						
22 2NO+1NC 						
28 1NO+2NC 			/			/
29 3NC 			/			/
30 3NC 			/			/
33 1NO+1NC 						
34 2NC 						
37 1NO+1NC 			/			
66 1NC 			/			
67 1NO 						

**Legend**

Closed contact | 
 Open contact | 
 Positive opening travel acc. to EN 60947-5-1 | 
 Switch pressed / 
 Switch released

## Switches for standard applications

## Maximum and minimum actuation speed - FR, FM, FX, FZ, FK series

## Roller lever - Type 1

$\varphi$	Vmax (m/s)	Vmin (mm/s)	
		L	R
15°	2,5	9	0,07
30°	1,5	8	
45°	1	7	
60°	0,75	7	

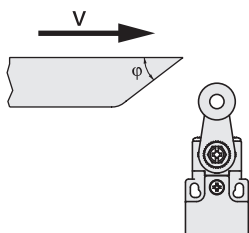

## Roller plunger - Type 2

$\varphi$	Vmax (m/s)	Vmin (mm/s)	
		L	R
15°	1	4	0,04
30°	0,5	2	0,02
45°	0,3	1	0,01

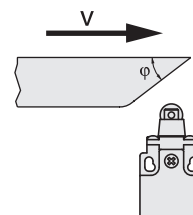

## Roller lever - Type 3

$\varphi$	Vmax (m/s)	Vmin (mm/s)	
		L	R
15°	1	5	0,05
30°	0,5	2,5	0,025
45°	0,3	1,5	0,015

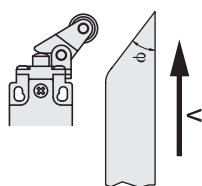

## Plunger - Type 4

Vmax (m/s)	Vmin (mm/s)	Vmin (mm/s)
	L	R
0,5	1	0,01

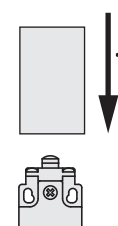

Contact type:

**R** = snap action  
**L** = slow action

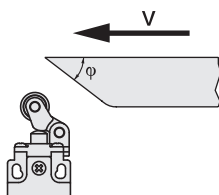

## Roller plunger - Type 5

$\varphi$	Vmax (m/s)	Vmin (mm/s)	
		L	R
15°	0,3	4	0,04
30°	0,2	2	0,02

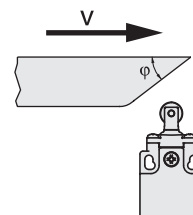

## Tightening torques – FR, FX, FK, FW series

1	Cover screws	0.7 ... 0.9 Nm
2	Head screws	0.5 ... 0.7 Nm
3	Lever screw	0.7 ... 0.9 Nm
4	Protection caps	1.2 ... 1.6 Nm
5	Contact block screws	0.6 ... 0.8 Nm
6	M4 fixing screws, body	2 ... 2.5 Nm
7	Actuator screws VF KEY...	1.2 ... 1.6 Nm

## Tightening torques – FM, FZ series

1	Cover screws	0.5 ... 0.7 Nm
2	Head screws	0.5 ... 0.7 Nm
3	Lever screw	0.8 ... 1.2 Nm
4	Protection caps	1.2 ... 1.6 Nm
5	Contact block screws	0.6 ... 0.8 Nm
6	M4 fixing screws, body	2 ... 3 Nm

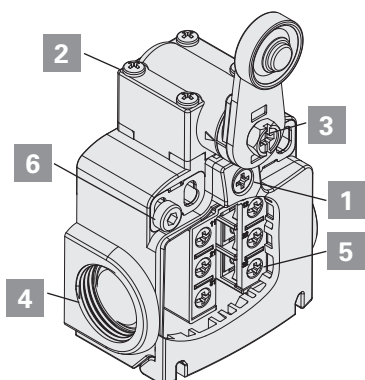

FR - FX - FK - FM

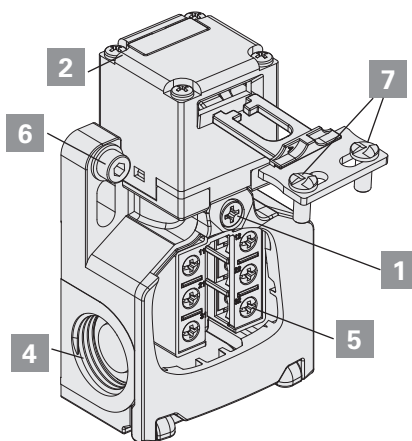

FW

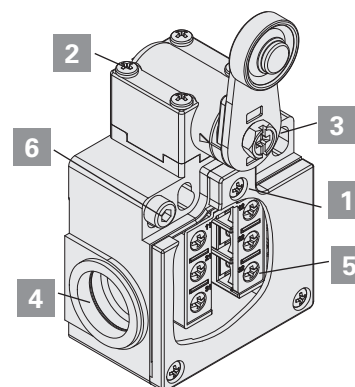

FZ



# FR, FM, FX, FZ, FK series switches for standard applications

## Travel diagrams

Contact block	Group 1	Group 2	Group 3	Group 4	Group 5	Group 6	Group 7 inverted contacts
2 2x(1NO-1NC) 							
3 1NO-1NC 							
5 1NO+1NC 							
6 1NO+1NC 				/			
7 1NO+1NC 				/			
9 2NC 				/			
10 2NO 							
11 2NC 				/		/	
12 2NO 							
13 2NC 				/			
14 2NC 				/			
15 2NO 				/			
16 2NC 	/	/	/	/		/	/
18 1NO+1NC 							
20 1NO+2NC 							
21 3NC 							
22 2NO+1NC 							
28 1NO+2NC 				/			
29 3NC 				/			
30 3NC 				/			
33 1NO+1NC 							
34 2NC 							
37 1NO+1NC 				/			
66 1NC 							
67 1NO 							

(\*) Positive opening of NC contacts (11-12 / 21-22 / 31-32) with 22 actuator with rigid rod only. Do not operate the 22 actuator with rigid rod at an angle of more than 27°.

### Legend

■ Closed contact | □ Open contact | ⊕ Positive opening travel acc. to EN 60947-5-1 | ▶ Switch pressed / ◀ Switch released

FR, FM, FX, FZ, FK series switches with W3 reset for standard applications

Travel diagrams

Contact block	Group 1	Group 2	Group 3	Group 4
<b>2</b> 2x(1NO-1NC) 				
<b>6</b> 1NO+1NC 				
<b>9</b> 2NC 				
<b>10</b> 2NO 				
<b>20</b> 1NO+2NC 				
<b>21</b> 3NC 				
<b>22</b> 2NO+1NC 				
<b>33</b> 1NO+1NC 				
<b>34</b> 2NC 				

**Legend**  
 Closed contact | Open contact | Positive opening travel acc. to EN 60947-5-1 | Switch pressed / Switch released | R reset engagement travel

# FR, FM, FX, FZ, FK, FW series switches for safety applications

## Travel diagrams

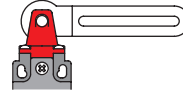

Contact block	Group 8	Group 9	Group 10	Group 11
5 1NO+1NC 				
6 1NO+1NC 				
7 1NO+1NC 			/	/
9 2NC 				
11 2NC 		/	/	/
13 2NC 		/	/	/
14 2NC 			/	/
18 1NO+1NC 				
20 1NO+2NC 				
21 3NC 				
22 2NO+1NC 				
33 1NO+1NC 				
34 2NC 				
37 1NO+1NC 		/	/	/
66 1NC 				

### Legend

Closed contact | 
 Open contact | 
 Positive opening travel acc. to EN 60947-5-1 | 
 Switch pressed / 
 Switch released

## NA, NB, NF series modular pre-wired switches

## Maximum and minimum actuation speed

## Roller lever - Type 1

$\varphi$	Vmax (m/s)	Vmin (mm/s) L	Vmin (mm/s) R
15°	2,5	9	0,07
30°	1,5	8	
45°	1	7	
60°	0,75	7	

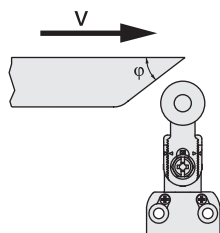

## Roller plunger - Type 2

$\varphi$	Vmax (m/s)	Vmin (mm/s) L	Vmin (mm/s) R
15°	1	4	0,04
30°	0,5	2	0,02
45°	0,3	1	0,01

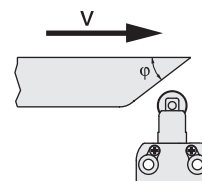

## Roller lever - Type 3

$\varphi$	Vmax (m/s)	Vmin (mm/s) L	Vmin (mm/s) R
15°	1	5	0,05
30°	0,5	2,5	0,025
45°	0,3	1,5	0,015

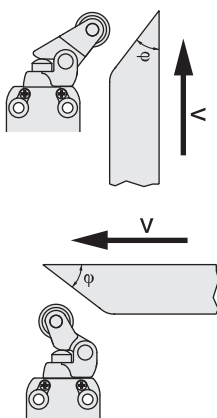

## Plunger - Type 4

Vmax (m/s)	Vmin (mm/s) L	Vmin (mm/s) R
0,5	1	0,01

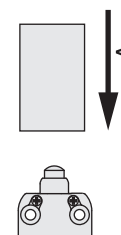

## Roller plunger - Type 5

$\varphi$	Vmax (m/s)	Vmin (mm/s) L	Vmin (mm/s) R
15°	0,3	4	0,04

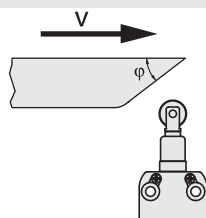

Contact type:

**R** = snap action  
**L** = slow action

## Screw tightening torques

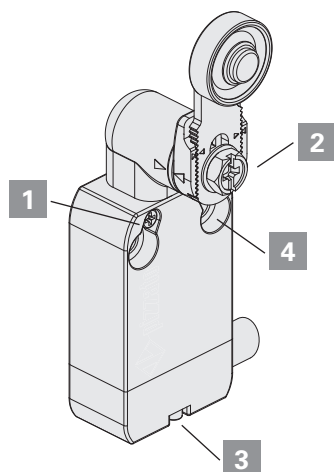

NA - NB - NF

## For NA and NB series:

1	Head screws	0.5 ... 0.7 Nm
2	Lever screw	0.8 ... 1.2 Nm
3	Connector screw	0.3 ... 0.6 Nm
4	M4 fixing screws, body	2 ... 3 Nm

## For NF series:

1	Head screws	0.3 ... 0.4 Nm
2	Lever screw	0.8 ... 1.2 Nm
3	Connector screw	0.2 ... 0.3 Nm
4	M4 fixing screws, body	2 ... 3 Nm

# NA, NB, NF series modular pre-wired switches

## Travel diagrams

Contact block	Group 1	Group 2	Group 3	Group 4	Group 5	Group 6
<b>B11</b> 1NO+1NC						
<b>B02</b> 2NC						
<b>B12</b> 1NO+2NC						
<b>B22</b> 2NO+2NC						
<b>C11</b> 1NO+1NC						
<b>C02</b> 2NC						
<b>C12</b> 1NO+2NC						
<b>C22</b> 2NO+2NC						
<b>G11</b> 1NO+1NC				/		
<b>G02</b> 2NC						
<b>G12</b> 1NO+2NC				/		
<b>G22</b> 2NO+2NC				/		
<b>H11</b> 1NO+1NC						
<b>H12</b> 1NO+2NC						
<b>H22</b> 2NO+2NC						
<b>L11</b> 1NO+1NC						
<b>L12</b> 1NO+2NC						
<b>L22</b> 2NO+2NC						
<b>BA1</b> 1NO+1NC change-over						

**Legend**

Closed contact | 
 Open contact | 
 Positive opening travel acc. to EN 60947-5-1 | 
 Switch pressed / 
 Switch released

## FA series modular pre-wired switches

## Maximum and minimum actuation speed

## Roller lever - Type 1

$\varphi$	Vmax (m/s)	Vmin (mm/s) L	Vmin (mm/s) R
15°	2,5	9	0,07
30°	1,5	8	
45°	1	7	
60°	0,75	7	

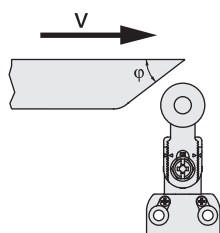

## Roller plunger - Type 2

$\varphi$	Vmax (m/s)	Vmin (mm/s) L	Vmin (mm/s) R
15°	1	4	0,04
30°	0,5	2	0,02
45°	0,3	1	0,01

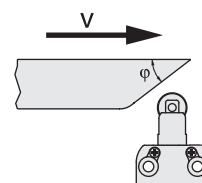

## Roller lever - Type 3

$\varphi$	Vmax (m/s)	Vmin (mm/s) L	Vmin (mm/s) R
15°	1	5	0,05
30°	0,5	2,5	0,025
45°	0,3	1,5	0,015

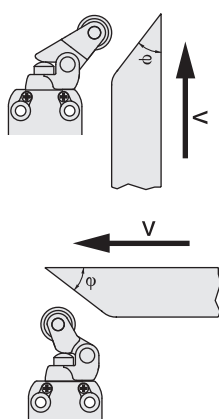

## Plunger - Type 4

Vmax (m/s)	Vmin (mm/s) L	Vmin (mm/s) R
0,5	1	0,01

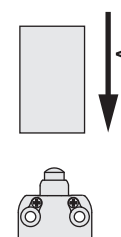

## Roller plunger - Type 5

$\varphi$	Vmax (m/s)	Vmin (mm/s) L	Vmin (mm/s) R
15°	0,3	4	0,04

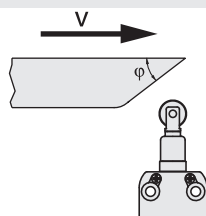

Contact type:

**R** = snap action  
**L** = slow action

## Screw tightening torques

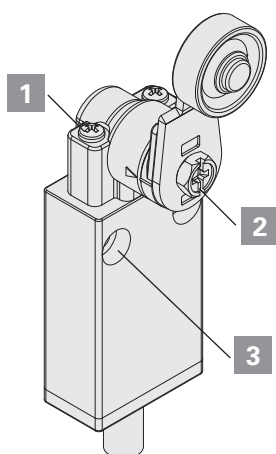













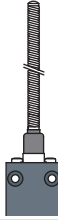



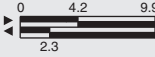
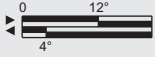

- 1 Head screws
- 2 Lever screw
- 3 M4 fixing screws, body

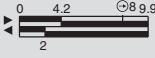
**0.5 ... 0.7 Nm**  
**0.8 ... 1.2 Nm**  
**2 ... 3 Nm**



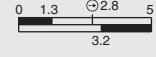

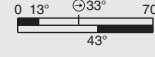
FA

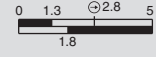
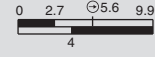
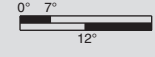
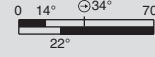
## FA series pre-wired switches

### Travel diagrams

					
Contact block		Group 1	Group 2	Group 3	Group 4
<b>41</b> 1NO+1NC					
<b>45</b> 1NO+1NC					
<b>46</b> 1NO+1NC					
<b>48</b> 1NO+1NC					

#### Legend

 Closed contact | 
  Open contact | 
  Positive opening travel acc. to EN 60947-5-1 | 
  Switch pressed / 
  Switch released

## MK series microswitches

## Maximum and minimum actuation speed

## Plunger - Type 1

V <sub>max</sub> (m/s)	V <sub>min</sub> (mm/s)
0,5	0,05

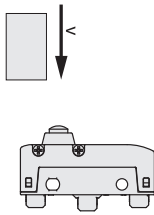

## Roller plunger - Type 2

$\phi$	V <sub>max</sub> (m/s)	V <sub>min</sub> (mm/s)
15°	0,6	0,2
30°	0,3	0,1
45°	0,1	0,05

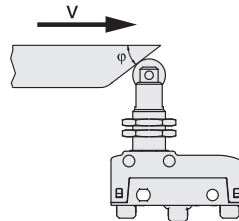

## Lever with direct action (D) - Type 3

V <sub>max</sub> (m/s)	V <sub>min</sub> (mm/s)
0,03 x L	0,0166 x L

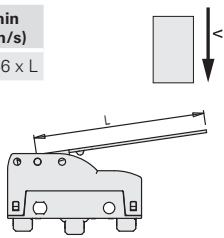

## Lever with inverted action (R) - Type 4

V <sub>max</sub> (m/s)	V <sub>min</sub> (mm/s)
0,015 x L	0,0083 x L

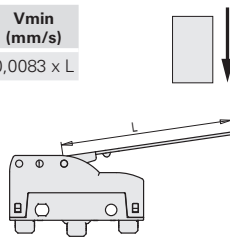

## Lever with direct action, rear (F) - Type 5

V <sub>max</sub> (m/s)	V <sub>min</sub> (mm/s)
0,01 x L	0,0047 x L

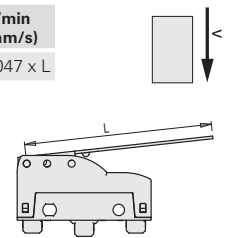

## Roller lever with direct action (D) - Type 6

$\phi$	V <sub>max</sub> (m/s)	V <sub>min</sub> (mm/s)
15°	0,1 x L	0,0664 x L
30°	0,05 x L	0,0332 x L
45°	0,03 x L	0,0166 x L

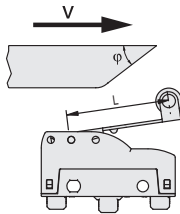

## Roller lever with inverted action (R) - Type 7

$\phi$	V <sub>max</sub> (m/s)	V <sub>min</sub> (mm/s)
15°	0,048 x L	0,0332 x L
30°	0,024 x L	0,0166 x L
45°	0,015 x L	0,0083 x L

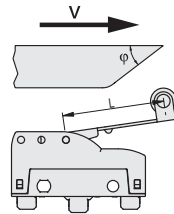

## Roller lever with direct action, rear (F) - Type 8

$\phi$	V <sub>max</sub> (m/s)	V <sub>min</sub> (mm/s)
15°	0,032 x L	0,0188 x L
30°	0,016 x L	0,0094 x L
45°	0,01 x L	0,0047 x L

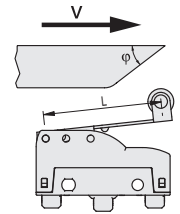

## Tightening torques

1	Head nuts	2 ... 3 Nm
2	Head screws	0.3 ... 0.4 Nm
3	Terminal screws	0.6 ... 0.8 Nm
4	M4 fixing screws, body (insert washer)	0.8 ... 1.2 Nm

Attention: A tightening torque higher than 1.2 Nm can cause the breaking of the microswitch.

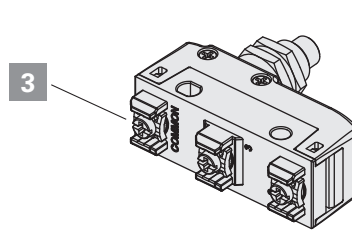
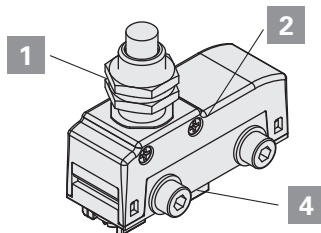



## MS, MF series microswitches

### Maximum and minimum actuation speed

#### Plunger - Type 1

V <sub>max</sub> (m/s)	V <sub>min</sub> (mm/s)
0,5	0,05

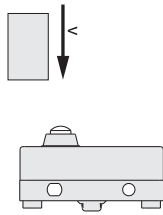

#### Roller plunger - Type 2

φ	V <sub>max</sub> (m/s)	V <sub>min</sub> (mm/s)
15°	0,6	0,2
30°	0,3	0,1
45°	0,1	0,05

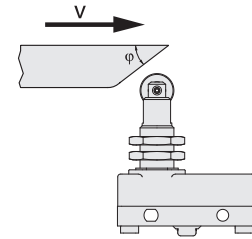

#### Lever with direct action (D) - Type 3

V <sub>max</sub> (m/s)	V <sub>min</sub> (mm/s)
0,03 x L	0,0166 x L

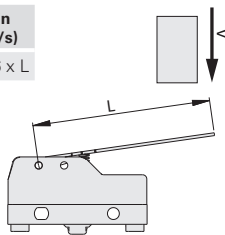

#### Roller lever with direct action (D) - Type 6

φ	V <sub>max</sub> (m/s)	V <sub>min</sub> (mm/s)
15°	0,1 x L	0,0664 x L
30°	0,05 x L	0,0332 x L
45°	0,03 x L	0,0166 x L

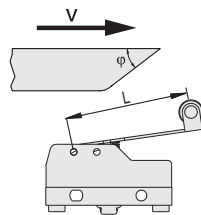

#### Roller lever with inverted action (R) - Type 7

φ	V <sub>max</sub> (m/s)	V <sub>min</sub> (mm/s)
15°	0,048 x L	0,0332 x L
30°	0,024 x L	0,0166 x L
45°	0,015 x L	0,0083 x L

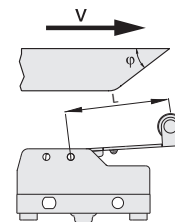

### Tightening torques

- |   |  |                       |
|---|--|-----------------------|
| 1 | Head nuts                              | <b>2 ... 3 Nm</b>     |
| 2 | Head screw                             | <b>0.3 ... 0.4 Nm</b> |
| 3 | Terminal screws                        | <b>0.6 ... 0.8 Nm</b> |
| 4 | M4 fixing screws, body (insert washer) | <b>0.8 ... 1.2 Nm</b> |

Attention: A tightening torque higher than 1.2 Nm can cause the breaking of the microswitch.

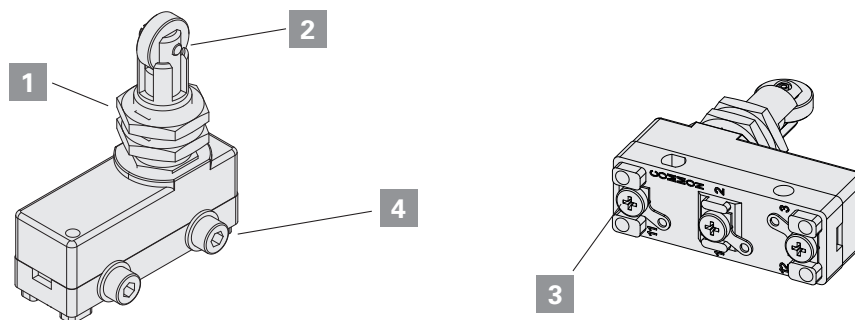

### General requirements

The device is designed to be installed on industrial machineries. The installation must be performed only by qualified staff aware of the regulations in force in the Country of installation. The device must be used exactly as supplied, properly fixed to the machine and wired.

It is not allowed to disassemble the product and use only parts of the same, the device is designed to be used in its assembly as supplied. It is prohibited to modify the device, even slightly e.g.: replace parts of it, drill it, lubricate it, clean it with gasoline or gas oil or any aggressive chemical agents.

The protection degree of the device refers to the electrical contacts only. Carefully evaluate all the polluting agents present in the application before installing the device, since the IP protection degree refers exclusively to agents such as dust and water according to EN 60529. Thus the device may not be suitable for installation in environments with dust in high quantity, condensation, humidity, steam, corrosive and chemical agents, flammable or explosive gas, flammable or explosive dust or other polluting agents.

Some devices are provided with a housing with openings for connecting the electrical cables. To guarantee an adequate protection degree of the device, the opening that the wiring passes through must be protected against the penetration of harmful materials by means of an appropriate seal. Proper wiring therefore requires the use of cable glands, connectors or other devices with IP protection degree that is equal to or greater than that of the device.

Store the products in their original packaging, in a dry place with temperature between  $-40^{\circ}\text{C}$  and  $+70^{\circ}\text{C}$

Failure to comply with these requirements or incorrect use during operation can lead to the damage of the device and the loss of the function performed by the device itself. This will result in termination of the warranty on the item and will release the manufacturer from any liability.

### Using the devices

- Before use, check if the national rules provide for further requirements in addition to those given here.
- Before installation, make sure the device is not damaged in any part.
- All devices are designed for actuation by moving parts of industrial machines.
- Do not use the device as a mechanical stop of the actuator.
- Do not apply excessive force to the device once it has reached the end of its actuation travel.
- Do not exceed the maximum actuation travel.
- Avoid contact of the device with corrosive fluids.
- Do not stress the device with bending or torsion.
- Do not disassemble or try to repair the device, in case of defect or fault replace the entire device.
- In case the device is deformed or damaged it must be entirely replaced. Correct operation cannot be guaranteed if the device is deformed or damaged.
- Always attach the following instructions to the manual of the machine in which the device is installed.
- If specific operating instructions exist for a device (supplied or downloadable from [www.pizzato.com](http://www.pizzato.com)), they must always be included with the machine manual and be available for the entire service life of the machine.
- These operating instructions must be kept available for consultation at any time and for the whole period of use of the device.

### Wiring and installation

- Installation must be carried out by qualified staff only.
- Use of the device is limited to function as a control switch.
- Observe minimum distances between devices (if provided).
- Comply with the tightening torques indicated in this catalogue.
- Keep the electrical load below the value specified by the respective utilization category.
- Disconnect the power before to work on the contacts, also during the wiring.
- Do not paint or varnish the devices.
- Install the product on flat and clean surfaces only.
- Do not bend or deform the device during installation.
- Never use the device as support for other machine components (cable ducts, tubes, etc.)
- For installation on the machine, use the intended bore holes in the housing. The device must be fixed with screws of adequate length and resistance to the expected stress. At least two screws (fitted to holes most suitable for the intended use) are required to fix the housing to the machine.
- After and during installation, do not pull the electrical cables connected to the device. If excessive tension is applied to the cables (that is not supported by an appropriate cable gland), the contact block of the device may be damaged.
- Provided that the device has an electrical connector, always switch off the circuit voltage before disconnecting the connector from the switch. The connector is not suitable for separation of electrical loads.
- During wiring comply with the following requirements:
  - for terminals (if present), comply with the minimum and maximum cross-sections of the conductors;
  - tighten the electrical terminals (if present) with the torque indicated in this catalogue;
  - do not introduce polluting agents into the device as: talc, lubricants for cable sliding, powder separating agents for multipolar cables, small strands of copper and other pollutants that could affect the proper functioning of the device;
  - before closing the device cover (if present) verify the correct positioning of the gaskets;
  - verify that the electrical cables, wire-end sleeves, cable numbering systems and any other parts do not obstruct the cover from closing correctly or if pressed between them do not damage or compress the internal contact block;
  - for devices with integrated cable, the free end of the cable must be properly connected inside a protected housing. The electrical cable must be properly protected from cuts, impacts, abrasion, etc.

- After installation and before commissioning of the machine, verify:
  - the correct operation of the device and all its parts;
  - the correct wiring and tightening of all screws;
  - the actuating travel of the actuator must be shorter than the maximum travel allowed by the device.
- After installation, periodically check for correct device operation.

#### **Do not use in following environments:**

- Environments where dust and dirt can cover the device and by sedimentation stop its correct working.
- Environment where sudden temperature changes cause condensation.
- Environments where coatings of ice may form on the device.
- Environments where the application causes knocks or vibrations that could damage the device.
- Environment with presence of explosive or flammable gas or dust. The current limit does not apply to devices declared compliant with directive ATEX 2014/34/EU.
- Prior to installation, the installer must ensure that the device is suitable for use under the ambient conditions on site.

#### **Limits of use**

- Use the devices following the instructions, complying with their operation limits and the standards in force.
- The devices have specific application limits (min. and max. ambient temperature, mechanical endurance, protection degree, utilisation category, etc.) These limits are met by the different devices only if considered individually and not if combined with each other. For further information contact our technical department.
- The utilization implies knowledge of and compliance with following standards: EN 60204-1, EN 60947-5-1, ISO 12100, EN ISO 14119.
- Please contact our technical department for information and assistance (phone +39.0424.470.930 – e-mail tech@pizzato.com) in the following cases:
  - cases not mentioned in the present utilization requirements.
  - in nuclear power stations, trains, airplanes, cars, incinerators, medical devices or any application where the safety of two or more persons depend on the correct operation of the device.

#### **Additional requirements for safety applications**

- Provided that all previous requirements for the devices are fulfilled, for installations with operator protection function additional requirements must be observed.
- The utilization implies knowledge of and compliance with following standards: IEC 60204-1, IEC 60947-5-1, ISO 12100, EN ISO 14119, EN IEC 62061, EN ISO 13849-1, EN ISO 13850.
- The protection fuse (or equivalent device) must be always connected in series with the NC contacts of the safety circuit.
- Periodically verify the correct working of the safety devices; the periodicity of this verification is settled by the machine manufacturer based on the machine danger degree and it does not have to be less than one a year.
- After installation and before commissioning of the machine, verify:
  - the correct operation of the device and all its parts;

- the correct wiring and tightening of all screws;
- the actuating travel of the actuator must be shorter than the maximum travel allowed by the device;
- the actuating travel of the actuator must be greater than the positive opening travel;
- the actuation system must be able to exert a force that is greater than the positive opening force.
- Devices with a safety function have a limited service life. Although still functioning, after 20 years from the date of manufacture the device must be replaced completely.
- The production date can be derived from the production batch on the item. Example: A23 FD7-411. The batch's first letter refers to the month of manufacture (A=January, B=February, etc.) The second and third letters refer to the year of manufacture (23 = 2023, 24 = 2024, etc...).

## Features

The contact blocks developed by Pizzato Elettrica are the result of more than 30 years of development experience and millions of sold switches. The range of available contact blocks is one of the most extensive in the world in the sector of position switches.

This chapter introduces to some features of Pizzato Elettrica contact blocks, in order to give the final user a better understanding of the technologies behind that element simply named "contact".

We underline that contact blocks are not available for sale (to the public) separately from switches, both because some of them are mechanically connected to the switch and because some technical features may change in accordance with the switch and its function. The following data is only intended to serve as an aid for the initial selection of the contact block. It is not to be used for determining the characteristics of the switch that uses this contact block. For example, the use of a contact block with positive opening with a switch with flexible actuator results in the combination of the two devices not having positive opening.

In this chapter, the properties of the E1 electronic contact block are explained in detail. It is used with position switches with multiple monitoring tasks that would require extensive effort to realize with electronic sensors. There is no other electronic sensor on the market that can match this contact unit with respect to precision and repeatability, adjustment of the switching point, operating temperature and price.

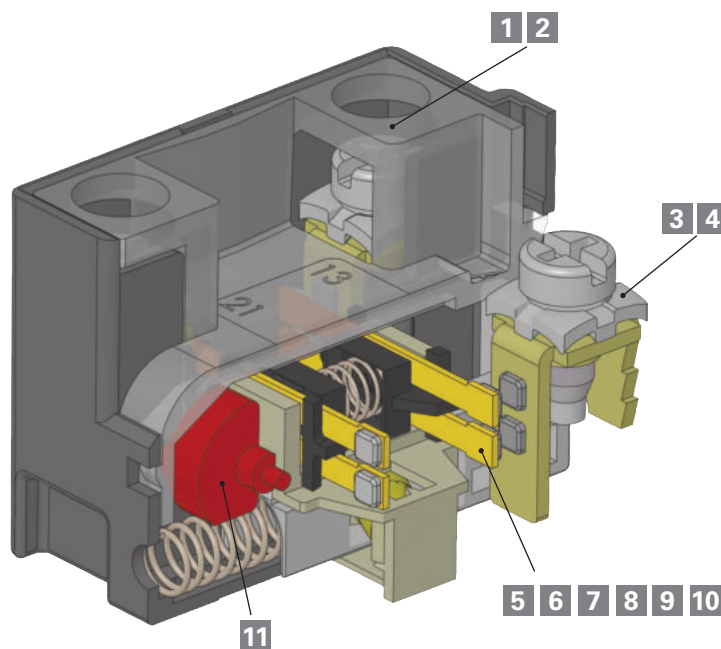

### Description

- 1** Captive screws
- 2** Finger protection
- 3** Clamping screw plates for cables with various diameters
- 4** Self-lifting clamping screw plates
- 5** Material of the contacts: Silver alloy or gold-plated silver alloy
- 6** Contact technology and reliability: Single bridge, double bridge
- 7** Operating voltages and currents for reliable switching

### Description

- 8** Classification of the contact type acc. to EN 60947-5-1: X, Y, C, Za, Zb
- 9** Contact type: Slow action / snap action / snap action with constant pressure
- 10** Force on contacts
- 11** Positive opening of contacts

## 1 Captive screws

Switches with this characteristic have clamping screws that remain in place even if completely unscrewed. This feature reduces wiring time, since the operator does not have to be careful not to unscrew the screws completely and does not risk to lose them by mistake, which is very useful in case of wirings in uncomfortable position.

## 2 Finger protection

All terminals in the contact blocks have protection degree IP20 in accordance with EN 60529, they are therefore protected against access to dangerous parts with a diameter greater than 12 mm.

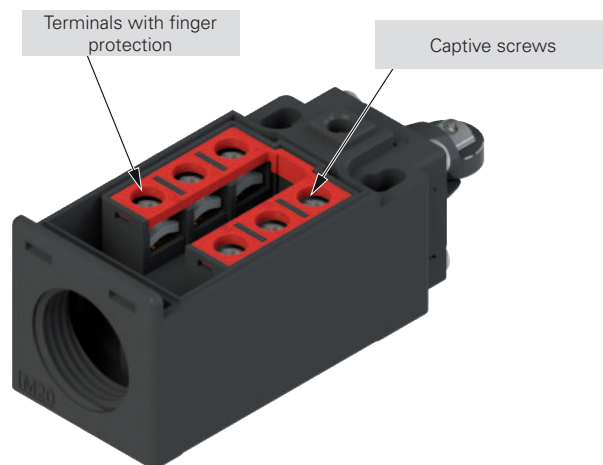

## 3 Clamping screw plates for cables with various diameters

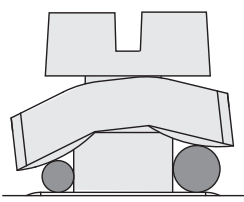

The clamping screw plates are provided with a particular "roofing tile" structure and are loosely coupled to the clamping screw. The design causes connection wires of different diameter to be pulled towards the screw when tightening the screw (see figure), preventing the wires from escaping towards the outside.

## 4 Self-lifting clamping screw plates

Switches with this feature are equipped with clamping screw plates that move up or down by turning the clamping screw; wiring is easier and faster as a result.

## 5 Material of the contacts: gold-plated silver alloy

The contact blocks can be supplied with silver electric contacts with a special gold-plated surface, with total gold thickness of one micron. This type of treatment can be useful in environments which are aggressive against silver (very humid or sulphurous atmospheres) and in case of very small electric loads, usually with low voltages and supply currents. This thickness of the gold coating permits several million switching cycles.

## 6 Contact technology and reliability

Very rarely, an electric contact does not function. A failed switching operation is a typical consequence of an exceptionally high contact resistance caused by dust, a thin layer of oxidation or other impurities that could penetrate the switch during wiring. Thus, the repeated occurrence of faulty switching depends not only on the sensor type, but also on its environmental conditions and the load that the switch drives. These effects are more evident with low electrical loads if the electric voltage cannot penetrate the thin layers of oxide or small grains of dust.

This type of malfunction can normally be tolerated with hand-operated devices, because repeating the operation is enough to restore the function. This is not the case with position switches, as severe machine damage could result if the end position is not ascertained.

In the following table we refer to two typical contact structures (type A and B) normally used in the industry and the ones which have been used by Pizzato Elettrica for several years in most switches: movable contacts with double interruption and twin bridge (type C).

As you can see from the table below, the last structure (type C) has the same contact resistance (**R**) as the simple mobile contact (type A), but with a lower failure probability (**fe**).

With a failure probability of **x** for a single switching operation, the failure probability for type A is **fe=x**, for type B **fe=2·x**, whereas for type C it is **fe=4·x<sup>2</sup>**.

This means that if the probability of a switching failure is **x** in a given situation, e.g.,  $1 \times 10^{-4}$ , (1 switching failure in 10,000), the result is as follows:

- for type A one failed commutation every 10,000.
- for type B one failed commutation every 5,000.
- for type C one failed commutation every 25,000,000.

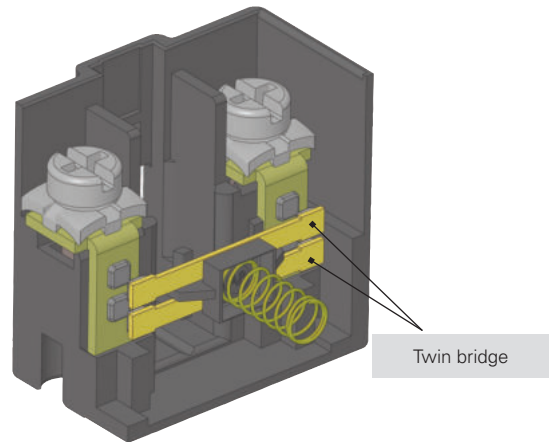

Type	Diagram	Description	Contact resistance R	Probability of errors fe
A		simple mobile contact	$R=R_c$	$fe=x$
B		mobile contact with double interruption	$R=2 \cdot R_c$	$fe=2x-x^2$
C		mobile contact with double interruption and twin bridge	$R= \frac{2 \cdot R_c}{2} = R_c$	$fe=4x^2-4x^3+x^4$

## 7 Minimum operating voltages and currents for reliable switching

The reliability of an electric contact depends on several factors, whose influence varies depending on the type of load. For high power loads is necessary for the contact to be able to dissipate the heat generated during switching. For low power loads, instead, it is important that it oxides and other impurities do not obstruct the passing of the electric signal. As a result, the material chosen for the electric contacts is a compromise among different and sometimes contrasting needs. In position switches contacts are usually made of a silver that has proved to be suitable for the switching of loads in the range of approximately 1 kW to 0.1 W. However, at lower loads, the effects of the oxide, which silver naturally develops upon contact with air, may occur; additionally to be taken into account are possible contaminations or impurities in the contact switching chamber (for example the talc powder in the cable sheaths that an installer could accidentally insert in the switch may have a similar effect).

It is impossible to define a fix threshold above which the "missing switching phenomenon" does not appear, because there are a lot of mechanical and electric parameters that influence this value. For example, in laboratory environment a good twin bridge electric contact is able to switch loads in the  $\mu\text{W}$  range for dozens of millions of handling operations, without losing signals. However, this does not mean that the same contact will have the same performance when the switch operates in environments with sudden changes of temperature (condensation) or where few switching occur (oxidation).

In order to avoid this kind of problem, gold plated contacts are used for very low loads profiting from the non-oxidability of this material. The gold-plating layer should be thick enough to be mechanically resistant to switching as well as electrically resistant to possible sparks that may vaporize it. For this reason Pizzato Elettrica uses micron thickness gold plating suitable for millions of working cycles. Thinner gold plating layers have often a purely aesthetic function and are only suitable to protect the product against oxidation during long time storage.

The minimum current and voltage values recommended by Pizzato Elettrica are shown in the diagram below, that is divided into two areas defined by a steady power limit. These values identify voltage and current combinations with high commutation reliability in most industrial fields. The lower voltage and current limits shown in the diagram are typical minimum values for industrial applications. They may also be reduced in non typical conditions. It is recommended, however, to always evaluate that the signal power to be switched is at least one magnitude order higher than the noise produced in the electric circuit, in particular when circuit cables are long and pass through areas with high electromagnetic fields and especially for powers lower than 10 mW.

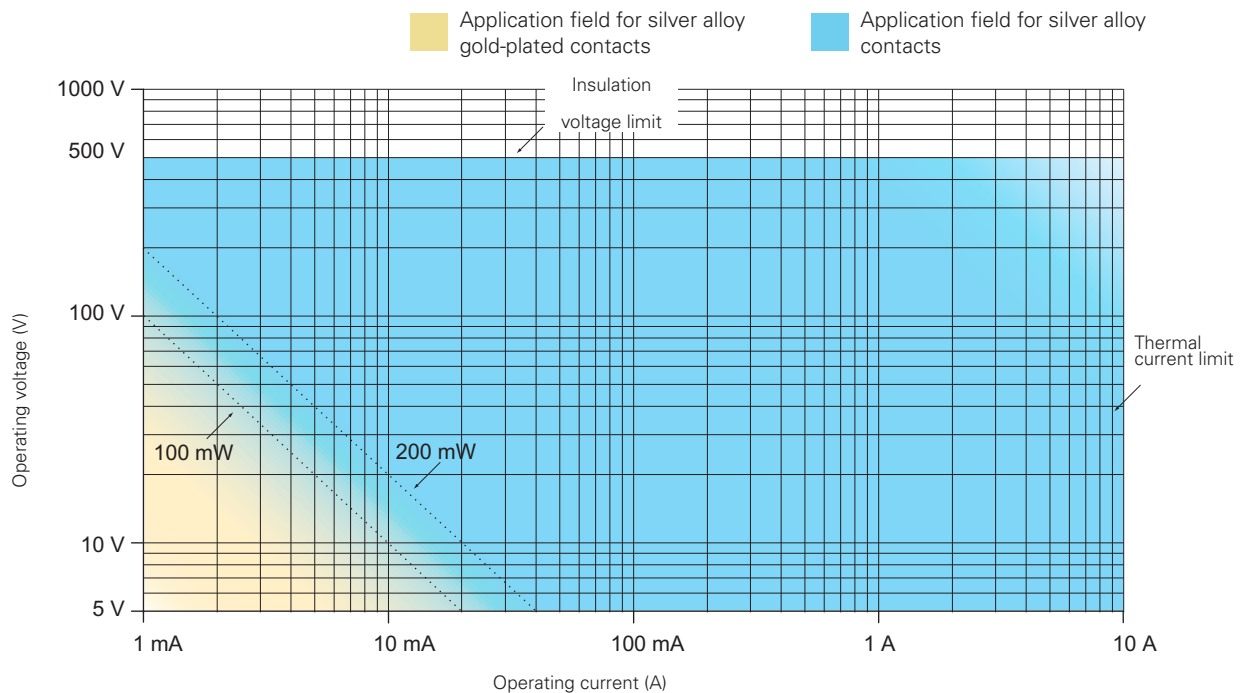

**100 mW** Suggested limit for general applications with snap action contact blocks with silver alloy contacts.

**200 mW** Recommended limit for general applications with slow action contact blocks with silver alloy contacts.

## 8 Classification of the contact block acc. to the EN 60947-5-1

Design	Figure	Symbol	Description
X			Double interruption contact element with two terminals
Y			
C			Change-over contact element with single interruption and three terminals
Za			Change-over contact element with double interruption and four terminals. <b>The contacts have identical polarity</b>
Zb			Change-over contact element with double interruption and four terminals. <b>Mobile contacts are electrically separated</b>

## Electrically separated contacts

The "+" symbol between two designs (e.g., X+X, Za+Za, X+X+Y, etc.) represents the combination of simple, **electrically separated** contact blocks.

The electrically separated contacts allow different voltages to be applied between the contacts and loads to be connected to different polarities (figure 1).

## Requirements and restrictions for Za contacts

Electrical loads must be connected to the same phase or polarity. The contacts **are not** electrically separated. As a result, different voltages may not be applied to the NC and NO contacts (figures 2 and 3).

According to EN 60947-5-1 section K.7.1.4.6.1, the following restrictions apply for positive opening contacts of design Za when used for safety applications.

If the control switch has changeover contact element of design C or Za, **only one contact element may be used** (closure or interruption). For changeover contact elements of design Zb, both contacts may be used.

## Contact design Zb

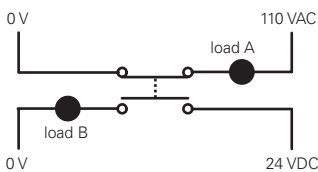

figure 1: correct

## Contact design Za

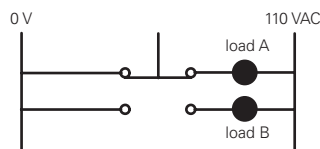

figure 2: correct

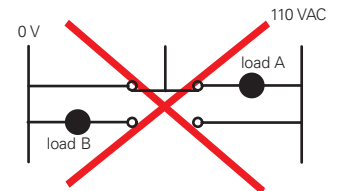

figure 3: incorrect



**9 Contact blocks with different operating principle: slow action and snap action**

**Contact blocks with slow action: component where the speed of the contact movement (V1) depends on the speed of the switch actuation (V).** The contact carrier moves at a rate proportional to the actuation speed.

The slow action contact block is suitable for applications having low to medium currents and quick actuation movements. It has no differential travel.

$$V = V1$$

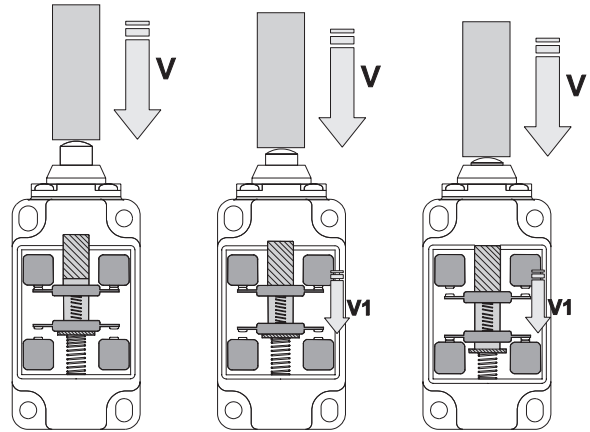

**Contact block with snap action: component where the speed of the contact movement (V1) doesn't depend on the speed of the switch actuation (V).** Upon reaching a predetermined point in the actuation travel, the contact carrier triggers and switches the contacts.

The snap action contact block is suitable for applications having high currents and/or slow actuation movements. This kind of contact block has a differential travel.

$$V \neq V1$$

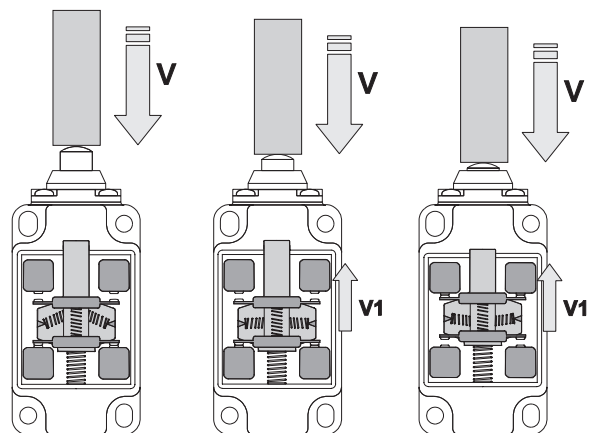

**10 Contact blocks: diagrams of the force on the contacts**

The following diagrams show the relationship between of the force exerted on the contacts (F) and the actuation travel to the end position.

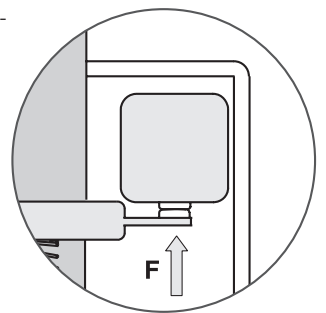
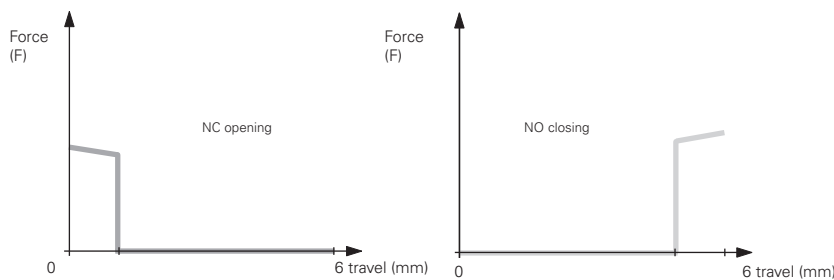

**Contact block with slow action**

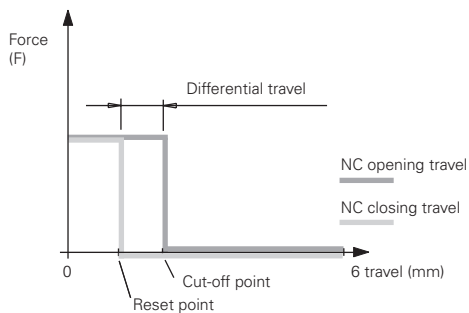

**Contact block with snap action and constant pressure: 5, 11, 12**  
The pressure on the contacts remains constant as the switching point is approached.

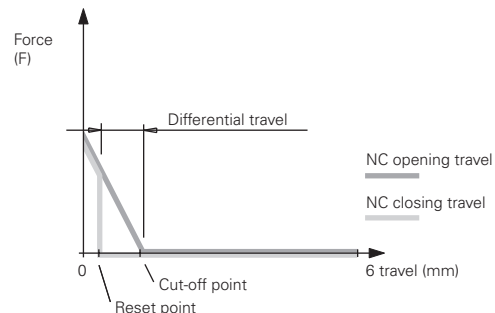

**Contact block with snap action: 2, 3, 17**  
The pressure on the contacts decreases as the switching point is approached.

## Contact blocks of the FD-FP-FL-FC-FR-FM-FX-FZ-FK-FW-FS series

Contact block	Contact diagram	Linear travel diagram	Contact design	Operation type	Positive opening $\ominus$	Contact type	Wire cross-section min.	Wire cross-section max.	Wire stripping length	Captive screws	Terminals with finger protection	Gold-plated contacts
2 2x (1NO-1NC)			Za+Za	snap action	no	Double interruption	1 x 0.5 mm <sup>2</sup> 1 x AWG 20	2 x 1.5 mm <sup>2</sup> 2 x AWG 16	6 mm	no	no	G
3 1NO-1NC			Za	snap action	no	Double interruption	1 x 0.5 mm <sup>2</sup> 1 x AWG 20	2 x 2.5 mm <sup>2</sup> 2 x AWG 14	6 mm	no	no	G
5 1NO+1NC			Zb	snap action	yes	Double interruption, twin bridge	1 x 0.5 mm <sup>2</sup> 1 x AWG 20	2 x 2.5 mm <sup>2</sup> 2 x AWG 14	8 mm	yes	yes	G / G1
6 1NO+1NC			Zb	slow action	yes	Double interruption, twin bridge	1 x 0.5 mm <sup>2</sup> 1 x AWG 20	2 x 2.5 mm <sup>2</sup> 2 x AWG 14	8 mm	yes	yes	G / G1
7 1NO+1NC			Zb	slow action	yes	Double interruption, twin bridge	1 x 0.5 mm <sup>2</sup> 1 x AWG 20	2 x 2.5 mm <sup>2</sup> 2 x AWG 14	8 mm	yes	yes	G / G1
8 1NC			Y	slow action	yes	Double interruption, twin bridge	1 x 0.5 mm <sup>2</sup> 1 x AWG 20	2 x 2.5 mm <sup>2</sup> 2 x AWG 14	8 mm	yes	yes	G / G1
9 2NC			Y+Y	slow action	yes	Double interruption, twin bridge	1 x 0.5 mm <sup>2</sup> 1 x AWG 20	2 x 2.5 mm <sup>2</sup> 2 x AWG 14	8 mm	yes	yes	G / G1
10 2NO			X+X	slow action	no	Double interruption, twin bridge	1 x 0.5 mm <sup>2</sup> 1 x AWG 20	2 x 2.5 mm <sup>2</sup> 2 x AWG 14	8 mm	yes	yes	G / G1
11 2NC			Y+Y	snap action	yes	Double interruption, twin bridge	1 x 0.5 mm <sup>2</sup> 1 x AWG 20	2 x 2.5 mm <sup>2</sup> 2 x AWG 14	8 mm	yes	yes	G / G1
12 2NO			X+X	snap action	no	Double interruption, twin bridge	1 x 0.5 mm <sup>2</sup> 1 x AWG 20	2 x 2.5 mm <sup>2</sup> 2 x AWG 14	8 mm	yes	yes	G / G1
13 2NC			Y+Y	slow action	yes	Double interruption, twin bridge	1 x 0.5 mm <sup>2</sup> 1 x AWG 20	2 x 2.5 mm <sup>2</sup> 2 x AWG 14	8 mm	yes	yes	G / G1
14 2NC			Y+Y	slow action	yes	Double interruption, twin bridge	1 x 0.5 mm <sup>2</sup> 1 x AWG 20	2 x 2.5 mm <sup>2</sup> 2 x AWG 14	8 mm	yes	yes	G / G1
15 2NO			X+X	slow action	no	Double interruption, twin bridge	1 x 0.5 mm <sup>2</sup> 1 x AWG 20	2 x 2.5 mm <sup>2</sup> 2 x AWG 14	8 mm	yes	yes	G / G1
16 2NC			Y+Y	slow action	yes	Double interruption, twin bridge	1 x 0.5 mm <sup>2</sup> 1 x AWG 20	2 x 2.5 mm <sup>2</sup> 2 x AWG 14	8 mm	yes	yes	G / G1
18 1NO+1NC			Zb	slow action	yes	Double interruption, twin bridge	1 x 0.5 mm <sup>2</sup> 1 x AWG 20	2 x 2.5 mm <sup>2</sup> 2 x AWG 14	8 mm	yes	yes	G / G1
20 1NO+2NC			Y+Y+X	slow action	yes	Double interruption, twin bridge	1 x 0.34 mm <sup>2</sup> 1 x AWG 22	2 x 1.5 mm <sup>2</sup> 2 x AWG 16	7 mm	yes	yes	G
21 3NC			Y+Y+Y	slow action	yes	Double interruption, twin bridge	1 x 0.34 mm <sup>2</sup> 1 x AWG 22	2 x 1.5 mm <sup>2</sup> 2 x AWG 16	7 mm	yes	yes	G
22 2NO+1NC			Y+X+X	slow action	yes	Double interruption, twin bridge	1 x 0.34 mm <sup>2</sup> 1 x AWG 22	2 x 1.5 mm <sup>2</sup> 2 x AWG 16	7 mm	yes	yes	G
28 1NO+2NC			Y+Y+X	slow action	yes	Double interruption, twin bridge	1 x 0.34 mm <sup>2</sup> 1 x AWG 22	2 x 1.5 mm <sup>2</sup> 2 x AWG 16	7 mm	yes	yes	G
29 3NC			Y+Y+Y	slow action	yes	Double interruption, twin bridge	1 x 0.34 mm <sup>2</sup> 1 x AWG 22	2 x 1.5 mm <sup>2</sup> 2 x AWG 16	7 mm	yes	yes	G
30 3NC			Y+Y+Y	slow action	yes	Double interruption, twin bridge	1 x 0.34 mm <sup>2</sup> 1 x AWG 22	2 x 1.5 mm <sup>2</sup> 2 x AWG 16	7 mm	yes	yes	G
33 1NO+1NC			Zb	slow action	yes	Double interruption, twin bridge	1 x 0.34 mm <sup>2</sup> 1 x AWG 22	2 x 1.5 mm <sup>2</sup> 2 x AWG 16	7 mm	yes	yes	G
34 2NC			Y+Y	slow action	yes	Double interruption, twin bridge	1 x 0.34 mm <sup>2</sup> 1 x AWG 22	2 x 1.5 mm <sup>2</sup> 2 x AWG 16	7 mm	yes	yes	G
37 1NO+1NC			Zb	slow action	yes	Double interruption, twin bridge	1 x 0.5 mm <sup>2</sup> 1 x AWG 20	2 x 2.5 mm <sup>2</sup> 2 x AWG 14	8 mm	yes	yes	G / G1
66 1NC			Y	slow action	yes	Double interruption, twin bridge	1 x 0.5 mm <sup>2</sup> 1 x AWG 20	2 x 2.5 mm <sup>2</sup> 2 x AWG 14	8 mm	yes	yes	G / G1
67 1NO			X	slow action	no	Double interruption, twin bridge	1 x 0.5 mm <sup>2</sup> 1 x AWG 20	2 x 2.5 mm <sup>2</sup> 2 x AWG 14	8 mm	yes	yes	G / G1
E1 1NO-1NC			PNP	electronic	no	Electronic	1 x 0.5 mm <sup>2</sup> 1 x AWG 20	1 x 1.5 mm <sup>2</sup> 1 x AWG 16	7 mm	no	no	/

Legend: G = gold-plated contacts 1 μm, G1 = gold-plated contacts 2.5 μm

## Contact blocks - NA-NB-NF series

Contact block	Contact diagram	Linear travel diagram	Contact design	Operation type	Positive opening ⊖	Contact type	Captive screws	Terminals with finger protection	Gold-plated contacts	
B11	1NO+1NC			Zb	snap action	yes	Double interruption	/	/	G
B02	2NC			Y+Y	snap action	yes	Double interruption	/	/	G
B12	1NO+2NC			X+Y+Y	snap action	yes	Double interruption	/	/	G
B22	2NO+2NC			X+X+Y+Y	snap action	yes	Double interruption	/	/	G
C11	1NO+1NC			Zb	snap action	yes	Double interruption	/	/	/
C02	2NC			Y+Y	snap action	yes	Double interruption	/	/	/
C12	1NO+2NC			X+Y+Y	snap action	yes	Double interruption	/	/	/
C22	2NO+2NC			X+X+Y+Y	snap action	yes	Double interruption	/	/	/
G11	1NO+1NC			Zb	slow action	yes	Double interruption	/	/	G
G02	2NC			Y+Y	slow action	yes	Double interruption	/	/	G
G12	1NO+2NC			X+Y+Y	slow action	yes	Double interruption	/	/	G
G22	2NO+2NC			X+X+Y+Y	slow action	yes	Double interruption	/	/	G
H11	1NO+1NC			Zb	slow action	yes	Double interruption	/	/	G
H12	1NO+2NC			X+Y+Y	slow action	yes	Double interruption	/	/	G
H22	2NO+2NC			X+X+Y+Y	slow action	yes	Double interruption	/	/	G
L11	1NO+1NC			Zb	slow action	yes	Double interruption	/	/	G
L12	1NO+2NC			X+Y+Y	slow action	yes	Double interruption	/	/	G
L22	2NO+2NC			X+X+Y+Y	slow action	yes	Double interruption	/	/	G
BA1	1NO+1NC change-over			C	snap action	yes	Double interruption	/	/	G

Legend: G = gold-plated contacts 1 μm

## Contact blocks - HP series

Contact block	Contact diagram	Linear travel diagram	Contact design	Operation type	Positive opening 	Contact type	Captive screws	Terminals with finger protection	Gold-plated contacts
50C 1NO+1NC			Zb	snap action	yes	Double interruption	/	/	G
50D 2NC			Y+Y	snap action	yes	Double interruption	/	/	G
50F 1NO+2NC			X+Y+Y	snap action	yes	Double interruption	/	/	G
50M 2NO+2NC			X+X+Y+Y	snap action	yes	Double interruption	/	/	G
52C 1NO+1NC			Zb	slow action	yes	Double interruption	/	/	G
52D 2NC			Y+Y	slow action	yes	Double interruption	/	/	G
52F 1NO+2NC			X+Y+Y	slow action	yes	Double interruption	/	/	G
52M 2NO+2NC			X+X+Y+Y	slow action	yes	Double interruption	/	/	G
53C 1NO+1NC			Zb	slow action	yes	Double interruption	/	/	G
53F 1NO+2NC			X+Y+Y	slow action	yes	Double interruption	/	/	G
53M 2NO+2NC			X+X+Y+Y	slow action	yes	Double interruption	/	/	G

Legend: G = gold-plated contacts 1 µm

## Contact blocks - FG, FY series

Contact block	Linear travel diagram	Contact design	Operation type	Positive opening	Contact type	Wire cross-section min. max.	Wire stripping length	Captive screws	Terminals with finger protection	Gold-plated contacts
60A 2NO+2NC		X+X+Y+Y	Slow action	yes	Double interruption, twin bridge and double contact point	1 x 0.34 mm <sup>2</sup> 2 x 1.5 mm <sup>2</sup> 1 x AWG 22	7 mm	yes	yes	G
60B 1NO+3NC		X+Y+Y+Y	Slow action	yes	Double interruption, twin bridge and double contact point	1 x 0.34 mm <sup>2</sup> 2 x 1.5 mm <sup>2</sup> 1 x AWG 22	7 mm	yes	yes	G
60C 4NC		Y+Y+Y+Y	Slow action	yes	Double interruption, twin bridge and double contact point	1 x 0.34 mm <sup>2</sup> 2 x 1.5 mm <sup>2</sup> 1 x AWG 22	7 mm	yes	yes	G
60D 1NO+3NC		X+Y+Y+Y	Slow action	yes	Double interruption, twin bridge and double contact point	1 x 0.34 mm <sup>2</sup> 2 x 1.5 mm <sup>2</sup> 1 x AWG 22	7 mm	yes	yes	G
60E 1NO+3NC		X+Y+Y+Y	Slow action	yes	Double interruption, twin bridge and double contact point	1 x 0.34 mm <sup>2</sup> 2 x 1.5 mm <sup>2</sup> 1 x AWG 22	7 mm	yes	yes	G
60F 2NO+2NC		X+X+Y+Y	Slow action	yes	Double interruption, twin bridge and double contact point	1 x 0.34 mm <sup>2</sup> 2 x 1.5 mm <sup>2</sup> 1 x AWG 22	7 mm	yes	yes	G
60G 4NC		Y+Y+Y+Y	Slow action	yes	Double interruption, twin bridge and double contact point	1 x 0.34 mm <sup>2</sup> 2 x 1.5 mm <sup>2</sup> 1 x AWG 22	7 mm	yes	yes	G
60H 4NC		Y+Y+Y+Y	Slow action	yes	Double interruption, twin bridge and double contact point	1 x 0.34 mm <sup>2</sup> 2 x 1.5 mm <sup>2</sup> 1 x AWG 22	7 mm	yes	yes	G
60I 1NO+3NC		X+Y+Y+Y	Slow action	yes	Double interruption, twin bridge and double contact point	1 x 0.34 mm <sup>2</sup> 2 x 1.5 mm <sup>2</sup> 1 x AWG 22	7 mm	yes	yes	G
60L 2NO+2NC		X+X+Y+Y	Slow action	yes	Double interruption, twin bridge and double contact point	1 x 0.34 mm <sup>2</sup> 2 x 1.5 mm <sup>2</sup> 1 x AWG 22	7 mm	yes	yes	G
60M 3NO+1NC		X+X+X+Y	Slow action	yes	Double interruption, twin bridge and double contact point	1 x 0.34 mm <sup>2</sup> 2 x 1.5 mm <sup>2</sup> 1 x AWG 22	7 mm	yes	yes	G
60N 3NO+1NC		X+X+X+Y	Slow action	yes	Double interruption, twin bridge and double contact point	1 x 0.34 mm <sup>2</sup> 2 x 1.5 mm <sup>2</sup> 1 x AWG 22	7 mm	yes	yes	G
60P 4NC		Y+Y+Y+Y	Slow action	yes	Double interruption, twin bridge and double contact point	1 x 0.34 mm <sup>2</sup> 2 x 1.5 mm <sup>2</sup> 1 x AWG 22	7 mm	yes	yes	G
60R 2NO+2NC		X+X+Y+Y	Slow action	yes	Double interruption, twin bridge and double contact point	1 x 0.34 mm <sup>2</sup> 2 x 1.5 mm <sup>2</sup> 1 x AWG 22	7 mm	yes	yes	G
60S 2NO+2NC		X+X+Y+Y	Slow action	yes	Double interruption, twin bridge and double contact point	1 x 0.34 mm <sup>2</sup> 2 x 1.5 mm <sup>2</sup> 1 x AWG 22	7 mm	yes	yes	G

Legend: G = gold-plated contacts 1 μm

## Contact blocks - FG, FY series

Contact block	Linear travel diagram	Contact design	Operation type	Positive opening	Contact type	Wire cross-section min.	max.	Wire stripping length	Captive screws	Terminals with finger protection	Gold-plated contacts
60T 1NO+3NC		X+Y+Y+Y	Slow action	yes	Double interruption, twin bridge and double contact point	1 x 0.34 mm <sup>2</sup> 1 x AWG 22	2 x 1.5 mm <sup>2</sup> 2 x AWG 16	7 mm	yes	yes	G
60U 4NC		Y+Y+Y+Y	Slow action	yes	Double interruption, twin bridge and double contact point	1 x 0.34 mm <sup>2</sup> 1 x AWG 22	2 x 1.5 mm <sup>2</sup> 2 x AWG 16	7 mm	yes	yes	G
60V 2NO+2NC		X+X+Y+Y	Slow action	yes	Double interruption, twin bridge and double contact point	1 x 0.34 mm <sup>2</sup> 1 x AWG 22	2 x 1.5 mm <sup>2</sup> 2 x AWG 16	7 mm	yes	yes	G
60X 1NO+3NC		X+Y+Y+Y	Slow action	yes	Double interruption, twin bridge and double contact point	1 x 0.34 mm <sup>2</sup> 1 x AWG 22	2 x 1.5 mm <sup>2</sup> 2 x AWG 16	7 mm	yes	yes	G
60Y 2NO+2NC		X+X+Y+Y	Slow action	yes	Double interruption, twin bridge and double contact point	1 x 0.34 mm <sup>2</sup> 1 x AWG 22	2 x 1.5 mm <sup>2</sup> 2 x AWG 16	7 mm	yes	yes	G
61A 1NO+3NC		X+Y+Y+Y	Slow action	yes	Double interruption, twin bridge and double contact point	1 x 0.34 mm <sup>2</sup> 1 x AWG 22	2 x 1.5 mm <sup>2</sup> 2 x AWG 16	7 mm	yes	yes	G
61B 2NO+2NC		X+X+Y+Y	Slow action	yes	Double interruption, twin bridge and double contact point	1 x 0.34 mm <sup>2</sup> 1 x AWG 22	2 x 1.5 mm <sup>2</sup> 2 x AWG 16	7 mm	yes	yes	G
61C 3NO+1NC		X+X+X+Y	Slow action	yes	Double interruption, twin bridge and double contact point	1 x 0.34 mm <sup>2</sup> 1 x AWG 22	2 x 1.5 mm <sup>2</sup> 2 x AWG 16	7 mm	yes	yes	G
61D 3NO+1NC		X+X+X+Y	Slow action	yes	Double interruption, twin bridge and double contact point	1 x 0.34 mm <sup>2</sup> 1 x AWG 22	2 x 1.5 mm <sup>2</sup> 2 x AWG 16	7 mm	yes	yes	G
61E 3NO+1NC		X+X+X+Y	Slow action	yes	Double interruption, twin bridge and double contact point	1 x 0.34 mm <sup>2</sup> 1 x AWG 22	2 x 1.5 mm <sup>2</sup> 2 x AWG 16	7 mm	yes	yes	G
61G 3NO+1NC		X+X+X+Y	Slow action	yes	Double interruption, twin bridge and double contact point	1 x 0.34 mm <sup>2</sup> 1 x AWG 22	2 x 1.5 mm <sup>2</sup> 2 x AWG 16	7 mm	yes	yes	G
61H 2NO+2NC		X+X+Y+Y	Slow action	yes	Double interruption, twin bridge and double contact point	1 x 0.34 mm <sup>2</sup> 1 x AWG 22	2 x 1.5 mm <sup>2</sup> 2 x AWG 16	7 mm	yes	yes	G
61M 3NO+1NC		X+X+X+Y	Slow action	yes	Double interruption, twin bridge and double contact point	1 x 0.34 mm <sup>2</sup> 1 x AWG 22	2 x 1.5 mm <sup>2</sup> 2 x AWG 16	7 mm	yes	yes	G
61R 1NO+3NC		X+Y+Y+Y	Slow action	yes	Double interruption, twin bridge and double contact point	1 x 0.34 mm <sup>2</sup> 1 x AWG 22	2 x 1.5 mm <sup>2</sup> 2 x AWG 16	7 mm	yes	yes	G
61S 3NO+1NC		X+X+X+Y	Slow action	yes	Double interruption, twin bridge and double contact point	1 x 0.34 mm <sup>2</sup> 1 x AWG 22	2 x 1.5 mm <sup>2</sup> 2 x AWG 16	7 mm	yes	yes	G

Legend: G = gold-plated contacts 1 μm

## Contact blocks - FS series

Contact block	Linear travel diagram	Contact design	Operation type	Positive opening	Contact type	Wire cross-section min. max.	Wire stripping length	Captive screws	Terminals with finger protection	Gold-plated contacts
18 1NO+1NC		Zb	Slow action	yes	Double interruption, twin bridge	1 x 0,5 mm <sup>2</sup> 1 x AWG 20 2 x 2,5 mm <sup>2</sup> 2 x AWG 14	8 mm	yes	yes	G / G1
20 1NO+2NC		Y+Y+X	Slow action	yes	Double interruption, twin bridge	1 x 0,34 mm <sup>2</sup> 1 x AWG 22 2 x 1,5 mm <sup>2</sup> 2 x AWG 16	7 mm	yes	yes	G
21 3NC		Y+Y+Y	Slow action	yes	Double interruption, twin bridge	1 x 0,34 mm <sup>2</sup> 1 x AWG 22 2 x 1,5 mm <sup>2</sup> 2 x AWG 16	7 mm	yes	yes	G
28 1NO+2NC		Y+Y+X	Slow action	yes	Double interruption, twin bridge	1 x 0,34 mm <sup>2</sup> 1 x AWG 22 2 x 1,5 mm <sup>2</sup> 2 x AWG 16	7 mm	yes	yes	G
29 3NC		Y+Y+Y	Slow action	yes	Double interruption, twin bridge	1 x 0,34 mm <sup>2</sup> 1 x AWG 22 2 x 1,5 mm <sup>2</sup> 2 x AWG 16	7 mm	yes	yes	G
30 3NC		Y+Y+Y	Slow action	yes	Double interruption, twin bridge	1 x 0,34 mm <sup>2</sup> 1 x AWG 22 2 x 1,5 mm <sup>2</sup> 2 x AWG 16	7 mm	yes	yes	G

Legend: G = gold-plated contacts 1 µm, G1 = gold-plated contacts 2.5 µm

## FD, FL, FM, FZ, FC series with metal housing

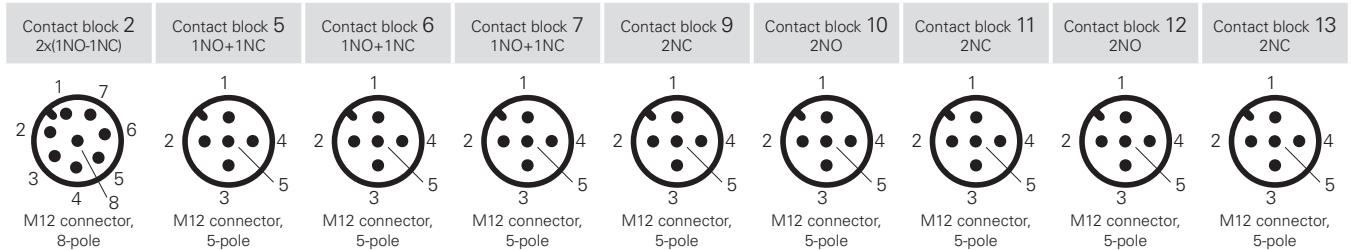

Contacts	Pin no.	Contacts	Pin no.	Contacts	Pin no.	Contacts	Pin no.	Contacts	Pin no.	Contacts	Pin no.	Contacts	Pin no.
NO	3-4	NC	1-2	NC	1-2	NC	1-2	NC	1-2	NO	1-2	NC	1-2
NC	5-6	NO	3-4	NO	3-4	NO	3-4	NC	3-4	NO	3-4	NC	3-4
NC	7-8	ground	5	ground	5	ground	5	ground	5	ground	5	ground	5
NO	1-2												

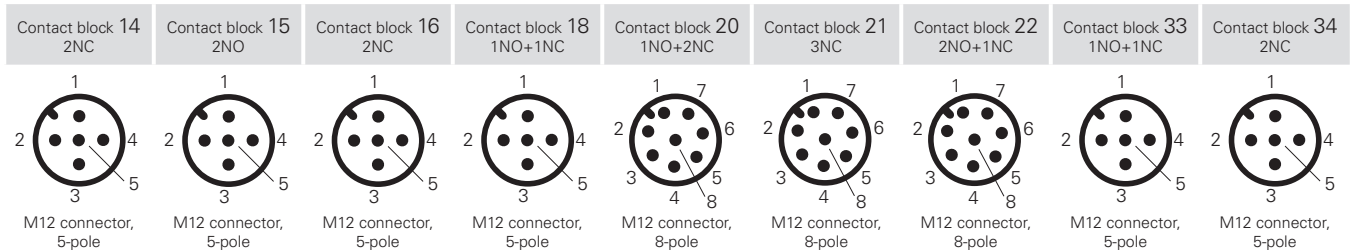

Contacts	Pin no.	Contacts	Pin no.	Contacts	Pin no.	Contacts	Pin no.	Contacts	Pin no.	Contacts	Pin no.	Contacts	Pin no.
NC (1°)	1-2	NO (1°)	1-2	NC, lever to the right	1-2	NC	1-2	NC	3-4	NC	3-4	NC	3-4
NC (2°)	3-4	NO (2°)	3-4	NC, lever to the left	3-4	NO	3-4	NC	5-6	NC	5-6	NO	5-6
ground	5	ground	5	ground	5	ground	5	NO	7-8	NC	7-8	NO	7-8
								ground	1	ground	1	ground	1

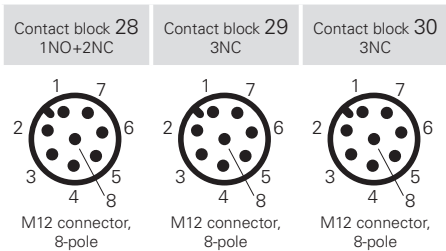

Contacts	Pin no.	Contacts	Pin no.	Contacts	Pin no.
NC	3-4	NC	3-4	NC	3-4
NC	5-6	NC	5-6	NC	5-6
NO	7-8	NC	7-8	NC	7-8
ground	1	ground	1	ground	1

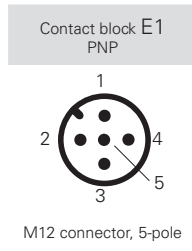

Contacts	Pin no.
+	1
-	3
NC	2
NO	4
ground	5



**For FP, FR, FX, FW series with technopolymer housing**

Contact block 2 2x(1NO-1NC)	Contact block 3 1NO+1NC	Contact block 5 1NO+1NC	Contact block 6 1NO+1NC	Contact block 7 1NO+1NC	Contact block 9 2NC	Contact block 10 2NO	Contact block 11 2NC	Contact block 12 2NO	
M12 connector, 8-pole	M12 connector, 4-pole	M12 connector, 4-pole	M12 connector, 4-pole	M12 connector, 4-pole	M12 connector, 4-pole	M12 connector, 4-pole	M12 connector, 4-pole	M12 connector, 4-pole	
Contacts	Pin no.	Contacts	Pin no.	Contacts	Pin no.	Contacts	Pin no.	Contacts	Pin no.
NO	3-4	NC	1-2	NC	1-2	NC	1-2	NO	1-2
NC	5-6	NO	3-4	NO	3-4	NO	3-4	NC	3-4
NC	7-8								
NO	1-2								

Contact block 13 2NC	Contact block 14 2NC	Contact block 15 2NO	Contact block 16 2NC	Contact block 18 1NO+1NC	Contact block 20 1NO+2NC	Contact block 21 3NC	Contact block 22 2NO+1NC	Contact block 33 1NO+1NC	
M12 connector, 4-pole	M12 connector, 4-pole	M12 connector, 4-pole	M12 connector, 4-pole	M12 connector, 4-pole	M12 connector, 8-pole	M12 connector, 8-pole	M12 connector, 8-pole	M12 connector, 4-pole	
Contacts	Pin no.	Contacts	Pin no.	Contacts	Pin no.	Contacts	Pin no.	Contacts	Pin no.
NC (1°)	1-2	NC (1°)	1-2	NO (1°)	1-2	NC, lever to the right	1-2	NC	1-2
NC (2°)	3-4	NC (2°)	3-4	NO (2°)	3-4	NC, lever to the left	3-4	NO	3-4
						NO	7-8	NC	5-6
						NC	5-6	NO	5-6
						NO	7-8	NO	7-8

Contact block 34 2NC	Contact block 28 1NO+2NC	Contact block 29 3NC	Contact block 30 3NC	Contact block E1 PNP	
M12 connector, 4-pole	M12 connector, 8-pole	M12 connector, 8-pole	M12 connector, 8-pole	M12 connector, 4-pole	
Contacts	Pin no.	Contacts	Pin no.	Contacts	Pin no.
NC	1-2	NC	3-4	+	1
NC	3-4	NC	5-6	-	3
		NO	7-8	NC	2
				NO	4

## 1- Introduction

The purpose of this section is to provide the machine manufacturer with a quick overview of a number of standards related to machine safety, to clarify some basic terms and to provide some application examples. This brief guide only covers aspects related to the functional safety of the machine, i.e., all measures that must be taken to protect the operating personnel from the hazards arising from the operation of the machine, as well as the project planning and selection of the appropriate interlocking devices for the given guard.

The machine designer himself must identify risks that are posed by other hazards, such as live parts, pressurised containers, explosive atmospheres, etc. These risks are not dealt with in this guideline.

Pizzato Elettrica prepared this document to the best of its knowledge, taking into consideration the standards, interpretations and existing technologies. The examples provided here must always be considered by the end customer with respect to the latest state of technology and standardisation. Pizzato Elettrica accepts no responsibility for the examples provided here and does not exclude the possibility of unintentional errors or inaccuracies.

## 2 - Design in safety. Structure of the European standards

To freely market any type of device or machine in the countries of the European Community, they must comply with the provisions of the EU directives. They establish the general principles for ensuring that manufacturers place products on the market that are not hazardous to the operating personnel. The vast range of products pose many different hazards and, over time, has led to the release of various directives. As an example, consider the Low Voltage Directive 2014/35/EU, the Equipment for Explosive Atmospheres (ATEX) Directive 2014/34/EU, the Electromagnetic Compatibility Directive 2014/30/EU, etc. The hazards that arise from the operation of machinery are described in the Machinery Directive 2006/42/EC.

Conformity with the directives is certified by the Declaration of Conformity issued by the manufacturer and by the application of the CE marking on the machine.

For the assessment of risks posed by a machine and for the realisation of the safety systems for protecting the operating personnel from those risks, the European standardisation organisations CEN and CENELEC have issued a series of standards which translate the contents of the directives into technical requirements. The standards published in the Official Journal of the European Union are harmonised. The manufacturer is to verify conformity with the applied and listed standards.

The machine safety standards are divided into three types: A, B and C.

Type A standards: Standards that cover basic concepts and general principles for design in order to achieve safety in the design of machinery.

Type B standards: Standards that deal with one or more safety aspects and are divided into the following standards:

- B1: Standards on particular safety aspects (e.g. safety distances, temperature, noise, etc.)
- B2: Standards on safeguards (e.g. two-hand controls, interlocking devices, guards, etc.)

Type C standards: Standards that deal with detailed safety requirements for a particular group of machines (e.g. hydraulic presses, injection moulding machines, etc.)

The system or machine manufacturer must therefore determine whether the product is covered by a type C standard. If this is the case, this standard specifies the safety requirements; otherwise, the type B standards shall apply for any specific aspect or device of the product. In the absence of specifications, the manufacturer shall follow the general guidelines stated in the type A standards.

### TYPE A STANDARDS

For example:

EN ISO 12100. Safety of machinery - General principles for design - Risk assessment and risk reduction.

### TYPE B1 STANDARDS

For example:

EN 62061. Safety of machinery - Functional safety of safety-related electrical, electronic and programmable electronic control systems  
EN ISO 13849-1 e -2. Safety-related parts of control systems

### TYPE B2 STANDARDS

For example:

EN ISO 13851. Two-hand control devices  
EN ISO 13850. Emergency stop  
EN ISO 14119. Interlocking devices associated with guards  
EN 60204-1. Electrical equipment of machines  
EN 60947-5-1. Electromechanical control circuit devices

### TYPE C STANDARDS

For example:

EN 201. Plastics and rubber machines - Injection moulding machines  
EN 415-1. Safety of packaging machines  
EN 692. Mechanical presses  
EN 693. Hydraulic presses  
EN 848-1. Safety of wood-working machines – One side moulding machines with rotating tool – Part 1: Single spindle vertical moulding machines

## 3 - Designing safe machines. Risk analysis

The first step in producing a safe machine is to identify the possible hazards to which the operators of a machine are exposed. The identification and classification of the hazards allows the risk for the operator or the combination of the probability of a hazard and the possible injury to be determined.

The methodology for risk analysis and evaluation and the procedure for the elimination/reduction of risks is defined by standard EN ISO 12100. This standard introduces a cyclic analysis model: starting with the initial objectives, the risk analysis and the various possibilities for reducing these risks are repeatedly evaluated until the initial objective is met.

The model introduced in this standard specifies that one proceed as follows after performing a risk analysis to reduce or eliminate risks:

- 1) Elimination of risks at their source through the use of intrinsically safe design principles and the structural set-up of the systems;
- 2) Risk reduction through safeguarding and monitoring systems;
- 3) Identification of residual risks through signalling and by informing the operating personnel.

Since every machine has hazards and because it is not possible to eliminate all possible risks, the objective is to reduce the residual risks to an acceptable level.

If a risk is reduced by means of a monitoring system, standard EN ISO 13849-1, which provides an evaluation model for the quality of this system, comes into play. If a given level is specified for a risk, it is possible to use a safety function of equal or higher level.

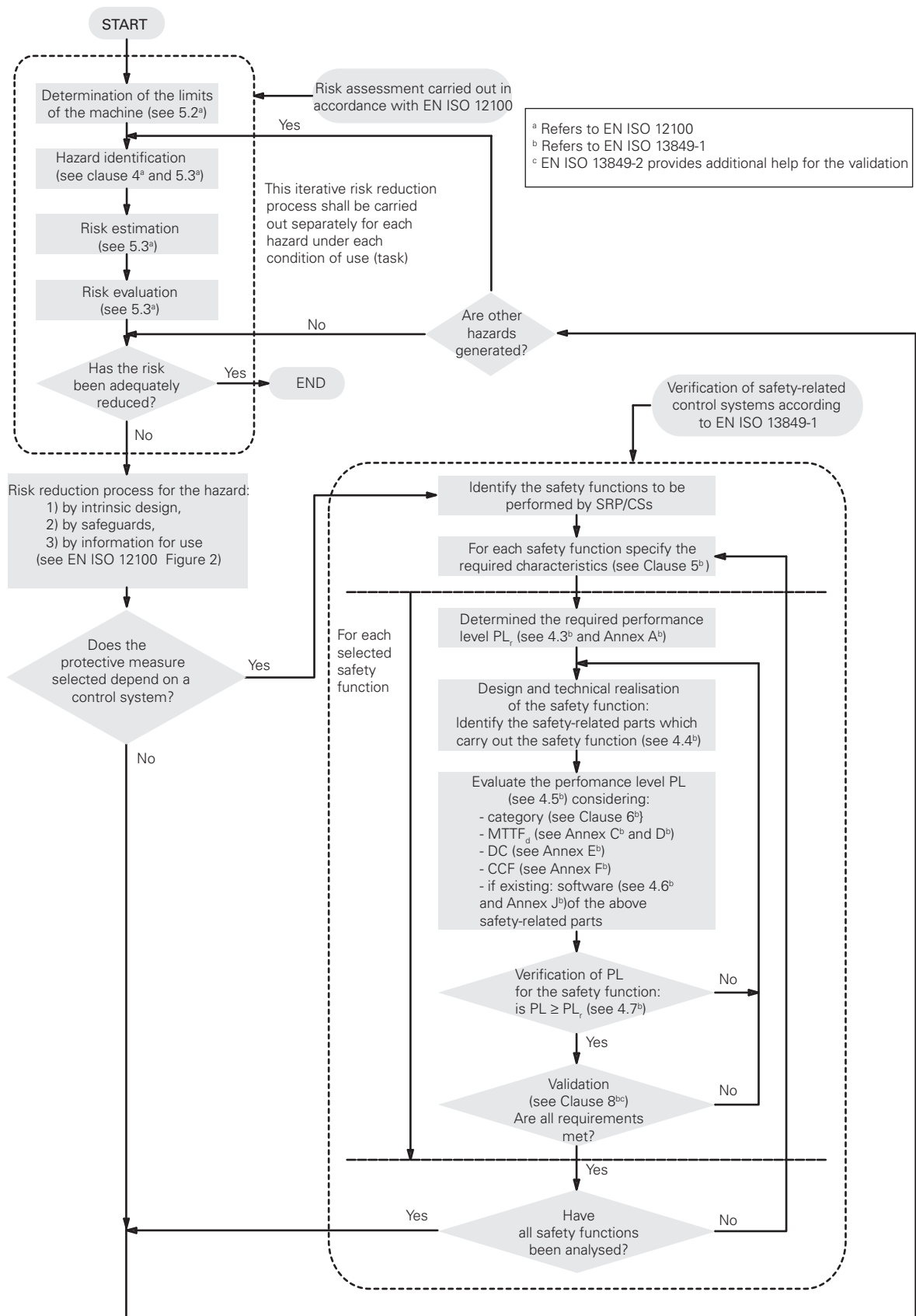

Note: This diagram was created by combining figures 1 and 3 of standard EN 13849-1. The texts in the diagram are not identical to those in the standard.

#### 4 - Positive opening, redundancy, diversification and self-monitoring

##### Positive mode and negative mode.

According to the standard EN ISO 12100, if a moving mechanical component inevitably moves another component along with it, either by direct contact or via rigid elements, these components are said to be connected in the **positive** mode. Instead, if the movement of a mechanical component simply allows another element to move freely, without using direct force (for example by gravity force, spring effect, etc.), that connection is said to be connected in the **negative** mode.

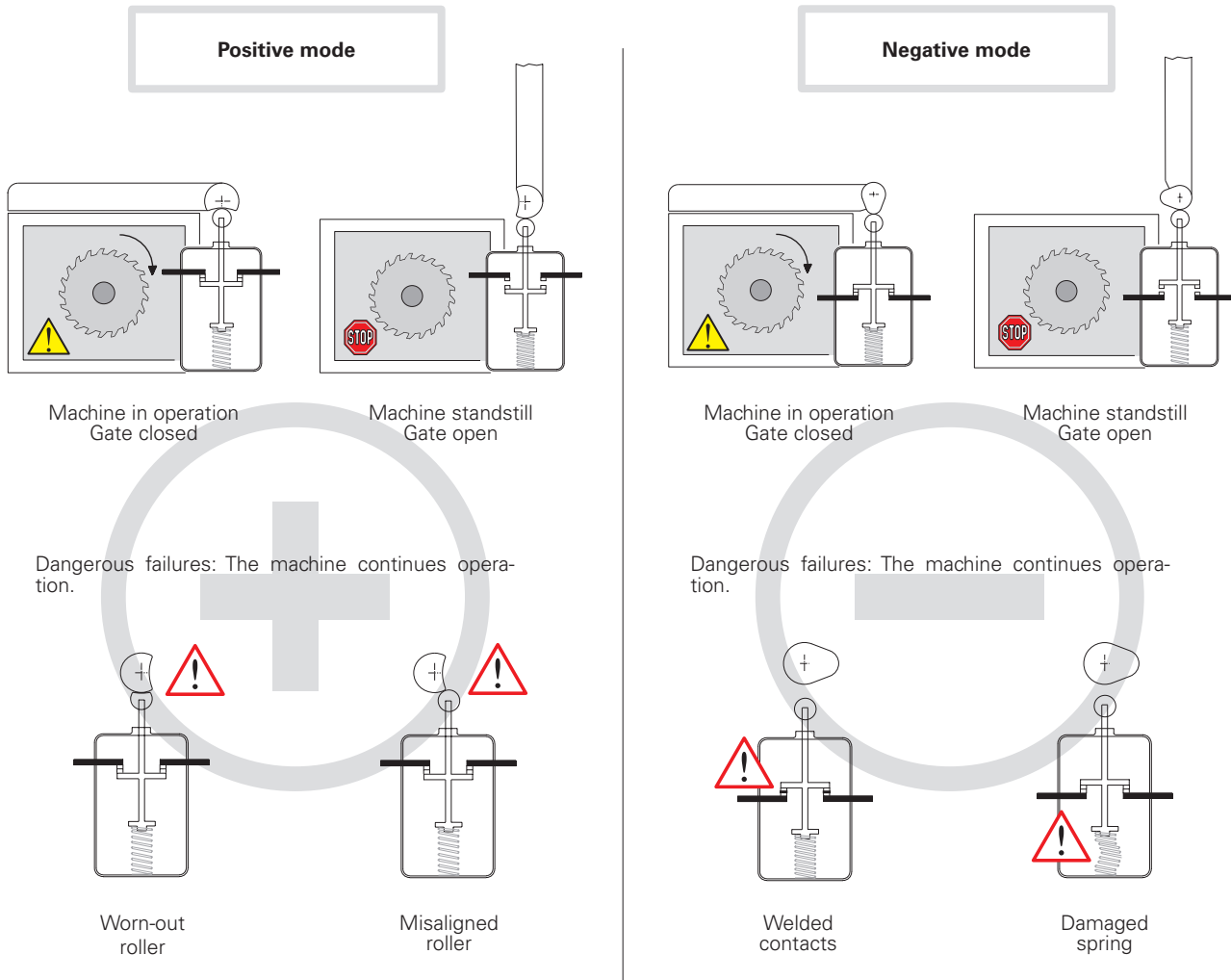

With positive mode, preventive maintenance can be performed, thereby avoiding the dangerous failures described above. With negative mode, on the other hand, failures can occur within the switch and are therefore difficult to detect.

**In the event of an internal failure (welded contacts or a damaged spring), the contacts will still open in positive mode in spite of the damage and the machine will be stopped.**



### Use of switches in safety applications

If only one switch is used in a safety application, the switch must be actuated in positive mode. In order to be used for safety applications, the opening contact (normally closed) must be with “**positive opening**”. All switches with the symbol  are provided with NC contacts with positive opening.

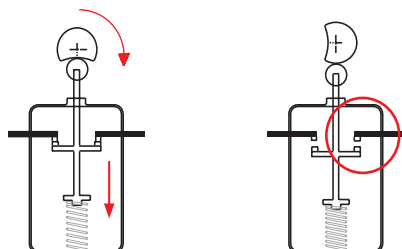

No flexible connection between the moving contacts and the actuator on which the actuating force is exerted.

In case of two or more switches, they should operate in opposite modes, for example:

- The first with an NC contact (normally closed contact), actuated by the guard in positive mode.
- The other with an NO contact (normally open contact), actuated by the guard in negative mode.

This is a common practice, though it does not exclude the possible use of two switches that are actuated in positive mode (see diversification).

### Diversification

In redundant systems, safety is increased through **diversification**. This can be obtained by using two switches with different design and/or technology; failures with the same cause can thereby be prevented. Examples for diversification include: the use of one switch with positive actuation and one switch without positive actuation, the use of one switch with mechanical actuation and one switch without mechanical actuation (e.g., electronic sensor) or the use of two switches with mechanical, positive actuation but with different types of actuation (e.g., an FR 693-M2 key switch and a switch with FR 1896-M2 hinge pin).

### Redundancy

**Redundancy** implies the use of more than one device or system to make sure that, in case of a failure in one device, there is another one available to perform the required safety functions. If the first failure is not detected, an additional failure may lead to the loss of the safety function.

### Self-monitoring

**Self-monitoring** consists in an automatic control performed to check the functioning of all devices involved in the machine working-cycle. This way the next working cycle can be either accepted or rejected.

### Redundancy and self-monitoring

Combining **redundancy** and **self-monitoring** in the same system makes sure that a first failure in the safety circuit does not lead to the loss of safety functions. This first failure will be detected at the next re-start or, in any case, before a second failure which may lead to the loss of the safety function.

## 5- Design and selection of interlocking devices associated with guards (standard EN ISO 14119)

The European standard EN ISO 14119 "Interlocking devices associated with guards – Principles for design and selection" came into force on October 2, 2013, and superseded EN 1088/ISO 14119:1998 as of May 2015.

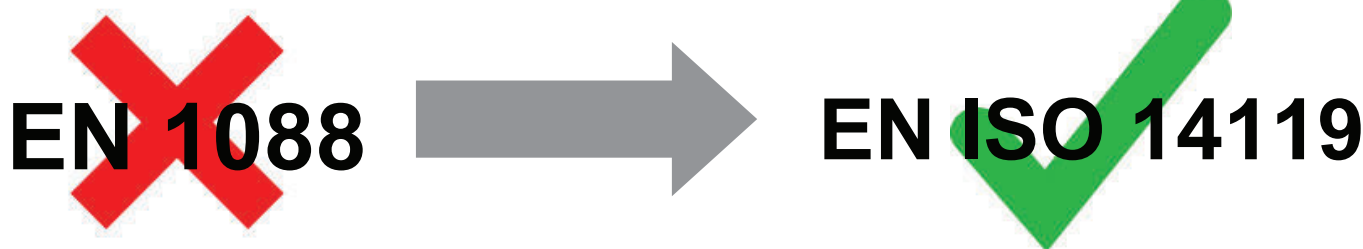

The standard is intended for manufacturers of interlocking devices as well as machine manufacturers (and integrators) and describes the requirements on the devices and their correct installation.

The new standard provides clarification to a number of questions that are not always clear cut and considers the latest technologies used in the design of interlocking devices, defines a number of parameters (actuator type and level of coding) and describes the procedure for correct installation with the goal of minimizing the defeat possibilities of the interlocking devices.

The standard also considers other aspects related to interlocking devices (e.g. guard locking principles, electromagnetic guard locking, auxiliary release, escape and emergency release, etc.) which are not described here.

### Coding level of the actuators

An important new addition to the standard is the definition of a coded actuator and the classification of the coding levels:

- **coded actuator** – actuator which was specially designed for use with a specific interlocking device;
- **low level coded actuator** – coded actuator for which 1 to 9 variations in code are available (e.g. the SR magnetic switch series or the safety switches with separate actuator and mechanical detection FS, FG, FR, FD...);
- **medium level coded actuator** – coded actuator for which 10 to 1000 variations in code are available;
- **high level coded actuator** – coded actuator for which more than 1000 variations are available. (e.g. the ST series sensors with RFID technology or the interlocking devices of the NG and NS series with RFID technology and guard locking).

### Types of interlocking devices



Standard EN ISO 14119 defines different types of interlocking devices:

- **Type 1 interlocking device** – interlocking device that is mechanically actuated by an uncoded actuator (e.g. HP series hinged interlocking devices)
- **Type 2 interlocking device** – interlocking device that is mechanically actuated by a coded actuator (e.g. safety switches with separate actuator of the FR, FS, FG, ... series)
- **Type 3 interlocking device** – interlocking device that is contactlessly actuated by an uncoded actuator
- **Type 4 interlocking device** – interlocking device that is contactlessly actuated by a coded actuator (e.g. ST series safety sensors with RFID technology and NG and NS series safety switches with RFID technology)

Examples of actuation principles		Actuator examples		Type
Mechanical	Direct contact/force	Uncoded	Rotary cam Linear cam Hinge	Type 1
		Coded	Key-actuated Trapped key	Type 2
Non-contact	Inductive	Uncoded	Ferromagnetic material	Type 3
	Magnetic		Magnet, solenoid	
	Capacitive		Any suitable object	
	Ultrasonic	Any suitable object		
Optic	Coded	Any suitable object	Type 4	
Magnetic		Coded magnet		
RFID		Coded RFID tag		
Optic		Optically coded tag		

Excerpt from EN ISO 14119 - Table 1

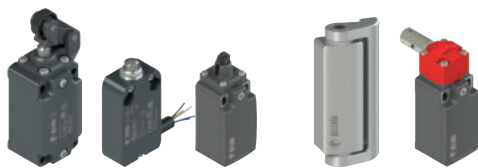
## Requirements for the design and the installation of interlocking devices according to EN ISO 14119 to reduce defeating of guards.

	Type 1 devices		Type 2 and type 4 devices	Type 2 and type 4 devices
	Cam safety switches rotary or linear cam	Safety hinge switches	Low and medium level coded actuators	High level coded actuators
Principles and measures against defeating				
Installation out of reach (1)	X		X	
Barriers or shielding (2)				
Installation in hidden position (3)				
Testing by means of control circuit (4)				
Non-detachable fixing of device and actuator				
Non-detachable fixing of the device		M		
Non-detachable fixing of the actuator		M	M	M
Additional interlocking device and plausibility check	R		R	

Excerpt from EN ISO 14119 - Table 3.

Legend: X = mandatory to apply at least one of the measures listed in the "Principles and measures" column; M = mandatory measure; R = recommended measure.

It is clear that the use of devices with RFID technology, high coding level and hinged switches is the easiest way to meet the requirements of EN ISO 14119, as it is only necessary to fulfil a few requirements in order to prevent defeating of guards. Devices with low or medium coding level require additional measures to ensure a tamperproof application.

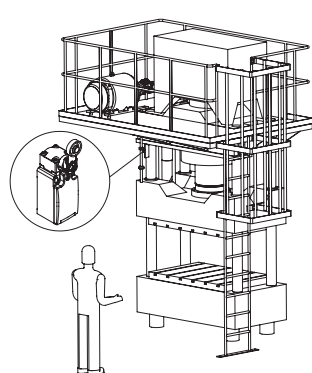

(1) - Installation out of reach

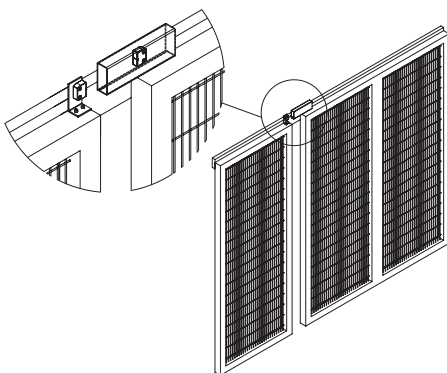

(2) - Barriers or shielding

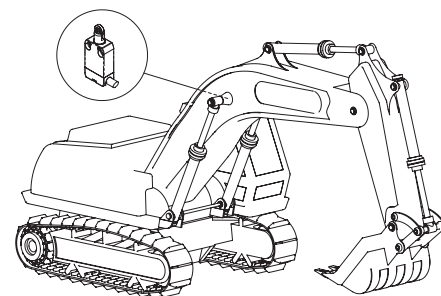

(3) - Installation in hidden position

(4) - Status monitoring or periodic testing can, for example, be performed on a machine with a simple operating cycle so as to verify that the guards are actually open at the end of or during specific operating phases (e.g. to remove the processed material or to perform quality controls). If status monitoring does not detect opening of the guard, an alarm is generated and the machine is stopped.

### Guard locking devices and holding force

The manufacturer of the interlocking device with guard locking must ensure that the device can withstand at least the measured holding force  $F_{zh}$  while the interlock is engaged. This holding force must not exceed the maximum holding force divided by a safety coefficient equal to 1.3.

Example: A device with maximum holding force of  $F_{zh} = 2000$  N must pass a test with a maximum holding force equal to  $F_{1max} = 2600$  N.

An interlocking device with guard locking can both monitor the position of the guard (open/closed) as well as lock the guard (locked/unlocked). Each of the two functions may require a different PL safety level (acc. to EN ISO 13849-1). The guard locking function generally requires a lower PL than the position monitoring function. (See paragraph 8.4, note 2 of EN ISO 14119).

To identify whether an interlocking device also performs status monitoring, the standard specifies that the product label includes the symbol shown to the side here.

$$F_{zh} = \frac{F_{1max}}{1,3}$$



## 6 - Current status of the standards. Reason for changes, new standards and some overlapping

The “traditional” standards for functional safety, such as EN 954-1, played a large part in formalising some of the basic principles for the analysis of safety circuits on the basis of deterministic principles. On the other hand, they make no mention of the topic of programmable electronic control systems and are not generally in line with the current state of technology. To take programmable electronic control systems into account in the analysis of safety circuits, the approach taken by current standards is fundamentally probabilistic and introduces new statistical variables.

This approach is based on IEC 61508, which deals with the safety of complex programmable electronic systems and is very extensive (divided into 8 sections with nearly 500 pages). It is also used in a diverse range of application fields (chemical industry, machine construction, nuclear plants). This standard introduces the SIL concept (Safety Integrity Level), a probabilistic indication of a system’s residual risk.

From IEC 61508 comes EN 62061, which covers the functional safety of the complex electronic or programmable control systems in industrial applications. The concepts introduced here permit general use for any safety-related electrical, electronic and programmable electronic control systems (systems with non-electrical technologies are not covered).

EN ISO 13849-1, developed by CEN under the aegis of ISO, is also based on this probabilistic approach. This standard, however, attempts to structure the transition to the concepts in a less problematic way for the manufacturer, who is accustomed to the concepts of EN 954-1. The standard covers electromechanical, hydraulic, “non-complex” electronic systems and some programmable electronic systems with predefined structures. EN ISO 13849-1 is a type B1 standard and introduces the PL concept (Performance Level); as with SIL, the concept provides a probabilistic indication of a machine’s residual risk. This standard points out a correlation between SIL and PL; concepts borrowed by EN 61508 – such as DC and CCF – are used and a connection to the safety categories of EN 954-1 is established.

In the area of functional safety for the safety of control circuits, there are thus two standards presently in force:

EN ISO 13849-1. Standard type B1, which uses the PL concept.

EN 62061. Standard type B1, which uses the SIL concept.

### Important note

EN 13849-1 is a type B1 standard; if a type C standard is already applied for a machine, the type C standard is to be used. Some type C standards not yet updated are based on the concepts of EN 954-1. For manufacturers of machines that are covered by a type C standard, the introduction time of the new standards depends on how quickly the various technical committees update the C standards.

There is clear overlapping of the two standards EN 62061 and EN ISO 13849-1 concerning their application field and many aspects are similar; there is also a link between the two symbol names (SIL and PL), which indicate the result of the analyses according to the two standards.

PL EN ISO 13849-1	a	b	c	d	e
SIL EN 62061 - IEC 61508	-	1	1	2	3
PFH <sub>D</sub>	from 10 <sup>-4</sup> to 10 <sup>-5</sup>	from 10 <sup>-5</sup> to 3x10 <sup>-6</sup>	from 3x10 <sup>-6</sup> to 10 <sup>-6</sup>	from 10 <sup>-6</sup> to 10 <sup>-7</sup>	from 10 <sup>-7</sup> to 10 <sup>-8</sup>
A hazardous failure every n years	from ~1 to ~10	from ~10 to ~40	from ~40 to ~100	from ~100 to ~1000	from ~1000 to ~10000

The choice of the standard to be applied is left to the manufacturer according to the technology that is used. We believe that standard EN ISO 13849-1 is easier to use thanks to its mediatory approach and the re-utilisation of the concepts already introduced on the market.



**7- Standard EN ISO 13849-1 and the new parameters: PL, MTTF<sub>D</sub>, DC, CCF**

Standard EN ISO 13849-1 offers the manufacturer an iterative method for assessing whether the hazards posed by a machine can be reduced to an acceptable residual level through the use of appropriate safety functions. The applied method specifies a hypothesis-analysis-validation cycle for each risk. Once completed, it must be possible to demonstrate that every selected safety function is appropriate for the respective risk.

The first step involves the determination of the required performance level, which is required of each safety function. Like EN 954-1, EN ISO 13849-1 also uses a risk graph for the risk analysis of a machine function (figure A.1). Instead of a safety category, however, this graph is used to determine – as a function of the risk – a Required Performance Level or PL<sub>r</sub> for the safety function which protects the respective part of the machine.

Starting with point 1 of the graph, the machine manufacturer answers questions S, F and P and can then determine the PL<sub>r</sub> for the safety function being examined. He must then develop a system with a performance level PL that is equal to or greater than that which is required to protect the operating personnel.

**Risk graph for determining the required PL<sub>r</sub> for the safety function (excerpt from EN ISO 13849-1, figure A.1)**

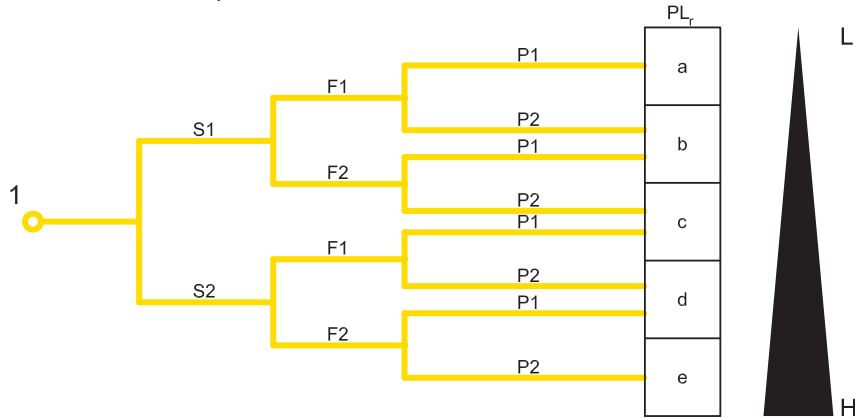

Key

- 1 Starting point for the evaluation of the safety function's contribution to risk reduction
- L Low contribution to risk reduction
- H High contribution to risk reduction
- PL<sub>r</sub> Required performance level

Risk parameters

- S** Severity of injury
  - S1** Slight (normally reversible injury)
  - S2** Serious (normally irreversible injury or death)
- F** Frequency and/or exposure to hazard
  - \*F1** Seldom-to-less-often and/or exposure time is short
  - \*\*F2** Frequent-to-continuous and/or exposure time is long
- P** Possibility of avoiding hazard or limiting harm
  - P1** Possible under certain conditions
  - P2** Scarcely possible

\* F1 should be selected if the total duration of the exposure to the hazard does not exceed 1/20 of the total work time and the frequency of exposure to the hazard does not exceed once every 15 minutes  
 \*\* If there are no other reasons, F2 should be selected if the frequency of exposure to the hazard is greater than once every 15 minutes.

Note: For a machine manufacturer, it may be of interest forego repeating the risk analysis of the machine and to instead to try and reuse the data already derived from the EN 954-1 risk analysis. This is not generally possible, since the risk graph changed with the new standard (see previous figure) and, as a result, the required performance level of the safety function may have changed with identical risks. The German Institute for Occupational Safety and Health (BGIA), in its report 2008/2 on EN ISO 13849-1, recommends the following: assuming the "worst case," implementation can occur according to the table to the right. For further information, refer to the mentioned report.

Category required by EN 954-1	Required performance level (PL <sub>r</sub> ) and category acc. to EN ISO 13849-1
B	→ b
1	→ c
2	→ d, Category 2
3	→ d, Category 3
4	→ e, Category 4

There are five performance levels, from PL a to PL e, with increasing risk; each represents a numerical range for the average probability of a dangerous failure per hour. For example, PL d specifies that the average probability of dangerous failures per hour is between 1x10<sup>-6</sup> and 1x10<sup>-7</sup>, i.e., about 1 dangerous failure every 100-1000 years.

PL	Average probability of dangerous failures per hour PFHd (1/h)	
a	≥ 10 <sup>-5</sup>	e < 10 <sup>-4</sup>
b	≥ 3 x 10 <sup>-6</sup>	e < 10 <sup>-5</sup>
c	≥ 10 <sup>-6</sup>	e < 3 x 10 <sup>-6</sup>
d	≥ 10 <sup>-7</sup>	e < 10 <sup>-6</sup>
e	≥ 10 <sup>-8</sup>	e < 10 <sup>-7</sup>

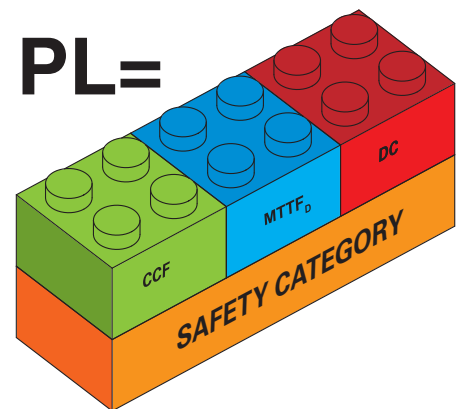

Several parameters are needed to determine the PL of a control system:

1. The safety category of the system, which is dependent on the architecture (structure) of the control system and its behaviour in the event of damage
2. MTTF<sub>D</sub> of the components
3. DC or Diagnostic Coverage of the system
4. CCF or Common Cause Failures



**Safety category.**

Most control circuits normally used can be represented with the following logic components:

- Input or signal input
- Logic or signal processing logic
- Output or output of the monitoring signal

These are connected to one another differently depending on the structure of the control circuit.

EN ISO 13849-1 allows for five different basic circuit structures, referred to as the designated architectures of the system. As shown in the following table, the architectures – combined with the requirements on the system behaviour in the event of failure and the minimum values of  $MTTF_D$ , DC and CCF – give the safety category of the system control. Thus, the safety categories of EN ISO 13849-1 are not the equivalent, but rather extend the concept of the safety category introduced by the previous standard EN 954-1.

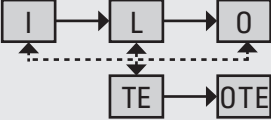
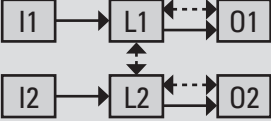
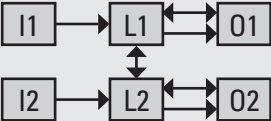
Category	Summary of the requirements	System behaviour	Safety principles	$MTTF_D$ of each channel	$DC_{avg}$	CCF
<b>B</b>	Safety-related parts of monitoring systems and/or their protective equipment, as well as their accessories, must be designed, constructed, selected, assembled and combined in accordance with the relevant standards so that they can withstand the expected influences. Fundamental safety principles must be used.  Architecture: 	The occurrence of a fault can lead to the loss of the safety function.	Mainly determined by the selection of components	Low to medium	None	Not relevant
<b>1</b>	In addition to the requirements of Category B, proven components and safety principles must be used.  Architecture: 	The occurrence of a fault can lead to the loss of the safety function; the probability of fault occurrence is, however, lower than for Category B.	Mainly determined by the selection of components	High	None	Not relevant
<b>2</b>	Requirements of Category B and proven safety principles must be used. The safety function must be checked at appropriate intervals by the control system.  Architecture: 	The occurrence of a fault between two checks can lead to the loss of the safety function. The loss of the safety function is detected through the check.	Determined mainly by the structure	Low to high	Low to medium	See Annex F
<b>3</b>	Requirements of Category B and proven safety principles must be used. Important safety-related parts must be designed so that: - A single fault in any of these parts does not lead to the loss of the safety function. - Where reasonably practicable, the single fault is detected.  Architecture: 	If a single fault occurs, the safety function is always performed. Some, but not all faults are detected. Accumulation of undetected faults can lead to the loss of the safety function.	Determined mainly by the structure	Low to high	Low to medium	See Annex F
<b>4</b>	Requirements of Category B and proven safety principles must be used. Important safety-related parts must be designed, so that: - a single fault in any of these parts does not lead to the loss of the safety function, and - a single fault during or before the next request for the safety function is detected. If this is not possible, the accumulation of undetected faults must not lead to the loss of the safety function.  Architecture: 	If a single fault occurs, the safety function is always performed. The detection of accumulated faults reduces the probability of the loss of the safety function (high DC). The faults are detected in time to prevent the loss of the safety function.	Determined mainly by the structure	High	High (including accumulation of faults)	See Annex F

### MTTF<sub>D</sub> ("Mean Time To Dangerous Failure").

This parameter is used to determine the functional system quality over the mean lifetime in years before a dangerous failure occurs (other failures are not considered). The calculation of the MTTF<sub>D</sub> is based on numerical values supplied by the manufacturers of the individual components of the system. In the absence of this data, the values can be taken from the tables with guide values included in the standard (EN ISO 13849-1 Annex C). The evaluation results in a numerical value, divided into three categories: High, Medium or Low.

Classification	Values
Not acceptable	MTTF <sub>D</sub> < 3 years
Low	3 years ≤ MTTF <sub>D</sub> < 10 years
Medium	10 years ≤ MTTF <sub>D</sub> < 30 years
High	(30 years ≤ MTTF <sub>D</sub> ≤ 100 years)

For components that are susceptible to high wear (typical for mechanical and hydraulic devices), the manufacturer supplies the value B<sub>10D</sub> for the component, i.e., the number of component operations within which 10% of the samples failed dangerously, instead of the MTTF<sub>D</sub> of the component.

The B<sub>10D</sub> value of the component must be converted to MTTF<sub>D</sub> by the machine manufacturer using the following formula:

$$MTTF_D = \frac{B_{10D}}{0,1 \cdot n_{op}}$$

Where n<sub>op</sub> = means number of annual operations for the component.

By assuming the daily operating frequency and the daily operating hours for the machine, n<sub>op</sub> can be calculated as follows:

$$n_{op} = \frac{d_{op} \cdot h_{op} \cdot 3600s/h}{t_{ciclo}}$$

where

d<sub>op</sub> = work days per year

h<sub>op</sub> = operating hours per day

t<sub>cycle</sub> = cycle time (s)

For components that are susceptible to wear, note that parameter MTTF<sub>D</sub> is dependent not only on the component itself but also on the application. An electromechanical device with low frequency of use, e.g. a remote switch that is only used for emergency stops, has a high MTTF<sub>D</sub>; if the same device is used for normal processes in the operating cycle, the MTTF<sub>D</sub> of the same remote switch could drop dramatically.

All elements of the circuit contribute to the calculation of the MTTF<sub>D</sub> depending on their structure. In control systems with single-channel architecture (as is the case in categories B, 1 and 2), the contribution of each components is linear and the MTTF<sub>D</sub> of the channel is calculated as follows:

$$\frac{1}{MTTF_D} = \sum_{i=1}^N \frac{1}{MTTF_{D_i}}$$

To avoid overly optimistic designs, the maximum value of the MTTF<sub>D</sub> of each channel is limited to 100 years (for categories B, 1, 2 and 3) or 2500 years (category 4). Channels with an MTTF<sub>D</sub> of less than 3 years are not allowed.

For two-channel systems (categories 3 and 4), the MTTF<sub>D</sub> of the circuit is calculated by averaging the MTTF<sub>D</sub> of the two channels using the following formula:

$$MTTF_D = \frac{2}{3} \left[ MTTF_{DC1} + MTTF_{DC2} - \frac{1}{\frac{1}{MTTF_{DC1}} + \frac{1}{MTTF_{DC2}}} \right]$$

### DC ("Diagnostic Coverage").

This parameter provides information on the effectiveness of a system's ability to self-detect any possible failures within the system. Using the percentage of the detectable dangerous failures, one obtains a diagnostic coverage of better or worse quality. The numerical DC parameter is a percentage value which is calculated using values taken from a table (EN ISO 13849-1 Annex E). Depending on the measures for failure detection taken by the manufacturer, example values are provided there. Because multiple measures are normally taken to rectify different anomalies in the same circuit, an average value or a DC<sub>avg</sub> is calculated and can be assigned four levels:

High	DC <sub>avg</sub> ≥ 99%
Medium	90% ≤ DC <sub>avg</sub> < 99%
Low	60% ≤ DC <sub>avg</sub> < 90%
None	DC <sub>avg</sub> < 60%

A diagnostic coverage of none is only permissible for systems of category B or 1.

### CCF ("Common Cause Failures")

For the calculation of the PL for systems of category 2, 3 or 4, it is also necessary to evaluate possible common cause failures or CCF, which may compromise the redundancy of the system. The evaluation is performed using a checklist (Annex F of EN ISO 13849-1); on the basis of the measures taken against common cause failures, points from 0 to 100 are assigned. The minimum permissible value for categories 2, 3 and 4 is 65 points.

**PL ("Performance Level")**

After determining this data, EN ISO 13849-1 gives the PL of the system using an assignment table (EN ISO 13849-1) or, alternatively, using a simplified graphic (EN ISO 13849-1, paragraph 4.5) as shown in the following:

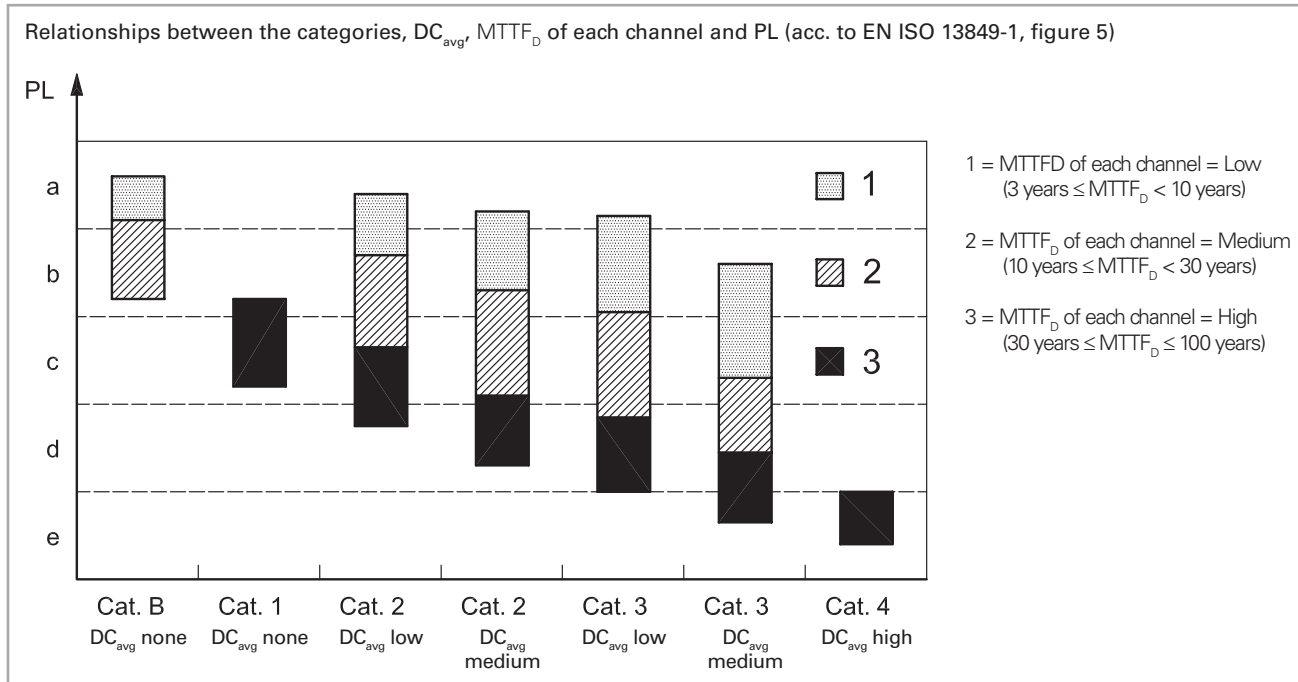

This figure is very useful, as it can be read from multiple points of view. For a given  $PL_r$ , it shows all possible solutions with which this PL can be achieved, i.e., the possible circuit structures that provide the same PL.

Considering the figure more closely, it is seen that the following possibilities exist for a system with PL equal to "c":

1. Category 3 system with less reliable components ( $MTTF_D$ =low) and medium DC.
2. Category 3 system with reliable components ( $MTTF_D$ =medium) and low DC.
3. Category 2 system with reliable components ( $MTTF_D$ =medium) and medium DC.
4. Category 2 system with reliable components ( $MTTF_D$ =medium) and low DC.
5. Category 1 system with very reliable components ( $MTTF_D$ =high).

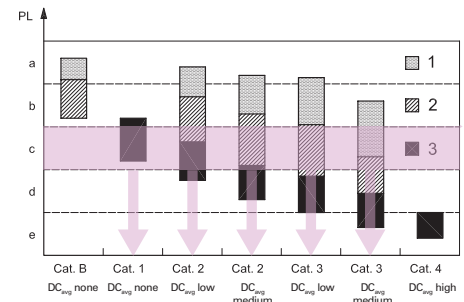

Considering a given circuit structure, in this figure one can also identify the maximum PL that can be reached depending on the average diagnostic coverage and the  $MTTF_D$  of the components.

Thus, the manufacturer can exclude a number of circuit structures in advance, as they do not meet the required  $PL_r$ .

However, the figure is not usually used to determine the PL of the system since the graphic areas overlap the boundaries of the different PL levels in many cases. Instead, the table in Annex K of standard EN ISO 13849-1 is used to precisely determine the PL of the circuit.

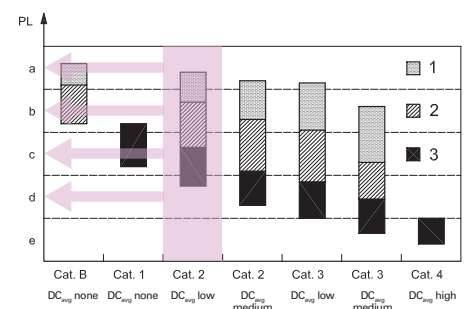



## Table of safety parameters

The  $B_{10D}$  data in the table refers to the mechanical life of the device contacts under normal ambient conditions.

The value of  $B_{10D}$  for NC and NO contacts refers to a maximum electrical load of 10% of the current value specified in the utilisation category. Mission time (for all articles listed below): 20 years.

### Electromechanical control devices

Series	Article description	$B_{10D}$ (NO)	$B_{10D}$ (NC)	$B_{10}/B_{10D}$
F•••••	Position switches	1,000,000	40,000,000	50%
F•••93	Safety switches with separate actuator	1,000,000	2,000,000	50%
F•••92				
F•••99	Safety switches with separate actuator with lock	1,000,000	1,000,000	50%
F••R2				
FG, FY	Safety switches with separate actuator with lock	1,000,000	5,000,000	20%
FS	Safety switches with separate actuator with lock	1,000,000	4,000,000	20%
F•••96	Safety switches with hinge pin	1,000,000	5,000,000	20%
F•••95				
F•••C•	Switches with slotted hole lever for hinged guards	1,000,000	2,000,000	50%
F•••••	Rope switches for emergency stop	100,000	200,000	50%
HP - HX B•22-•••	Safety hinges	1,000,000	5,000,000	20%
SR	Magnetic safety sensors (with compatible Pizzato Elettrica safety modules)	20,000,000	20,000,000	50%
SR	Magnetic safety sensors (used at max. load: DC12 24 V 250 mA)	400,000	400,000	100%
PX, PA	Foot switches	1,000,000	20,000,000	50%
MK	Micro position switches	1,000,000	20,000,000	50%
NA B•• - NA G•• - NA H•• - NA L••				
NB B•• - NB G•• - NB H•• - NB L••	Modular pre-wired position switches	1,000,000	40,000,000	50%
NF B•• - NF G•• - NF H•• - NF L••				
NA C•• - NB C•• - NF C••	Modular pre-wired position switches	1,000,000	10,000,000	50%
E2 C•••••••	Contact block	1,000,000	40,000,000	50%

Series	Article description	$B_{10D}$	$B_{10}/B_{10D}$
E2 •PU1•••••••	Single buttons, maintained	2,000,000	50%
E2 •PL1•••••••			
E2 •PU2•••••••	Single buttons, spring-return	30,000,000	50%
E2 •PL2•••••••			
E2 •PD•••••••, E2 •PT•••••••	Double and triple buttons	2,000,000	50%
E2 •PQ•••••••	Quadruple buttons	2,000,000	50%
E2 •PE•••••••	Emergency stop buttons	600,000	50%
VN NG-AC2605•	Emergency stop buttons integrated into NG, NS, BN series devices	100,000	50%
E2 •SE•••••••, E2 •SL•••••••	Selector switches with and without illumination	2,000,000	50%
E2 •SC•••••••	Key selector switches	600,000	50%
E2 •MA•••••••	Joysticks	2,000,000	50%

ATEX series	Article description	$B_{10D}$ (NO)	$B_{10D}$ (NC)	$B_{10}/B_{10D}$
F•••••-EX•	Position switches	500,000	20,000,000	50%
F•••93-EX•	Safety switches with separate actuator	500,000	1,000,000	50%
F•••99-EX•	Safety switches with separate actuator with lock	500,000	500,000	50%
F••R2-EX•				
F•••96-EX•	Safety switches with hinge pin	500,000	2,500,000	20%
F•••95-EX•				
F•••C•-EX•	Switches with slotted hole lever for hinged guards	500,000	1,000,000	50%
F•••••-EX•	Rope switches for emergency stop	500,000	1,000,000	50%

### Electronic devices

Code/series	Article description	MTTF <sub>D</sub>	DC	PFH <sub>D</sub>	SIL CL	PL	Cat
HX BEE1-•••	Safety hinges with electronic unit	2413	High	1.24E-09	3	e	4
ST D•••••••	Safety sensors with RFID technology	4077	High	1.20E-11	3	e	4
ST G•••••••, ST H•••••••	Safety sensors with RFID technology	1551	High	1.19E-09	3	e	4
	RFID safety switches with lock						
	Monitoring function: actuator locked - Mode 1	2968	High	1.15E-09	3	e	4
	Monitoring function: actuator present - Mode 2	3946	High	1.15E-09	3	e	4
NG	Monitoring function: actuator locked - Mode 3	2957	High	1.48E-09	2	d	2
	Monitoring function: actuator present - Mode 3	3927	High	1.48E-09	2	d	2
	Dual-channel control for locking function of the actuator	4011	High	1.51E-10	3	e	4
	Single-channel control for locking function of the actuator	4011	High	1.51E-10	2	d	2
	RFID safety switches with lock						
	Monitoring function: actuator locked - Mode 1	2657	High	1.23E-09	3	e	4
	Monitoring function: actuator present - Mode 2	1840	High	1.22E-09	3	e	4
NS	Monitoring function: actuator locked - Mode 3	2627	High	1.50E-09	2	d	2
	Monitoring function: actuator present - Mode 3	3987	High	1.49E-09	2	d	2
	Dual-channel control for locking function of the actuator	2254	High	2.04E-10	3	e	4
	Single-channel control for locking function of the actuator	2254	High	2.04E-10	2	d	2

$B_{10D}$ : Number of operations after which 10% of the components have failed dangerously

$B_{10}$ : Number of operations after which 10% of the components have failed

$B_{10}/B_{10D}$ : ratio of total failures to dangerous failures.

MTTF<sub>D</sub>: Mean Time To Dangerous Failure

DC: Diagnostic Coverage

PFH<sub>D</sub>: Probability of Dangerous Failure per hour

SIL CL: Safety Integrity Level Claim Limit. Maximum achievable SIL according to EN 62061

PL: Performance Level. PL acc. to EN ISO 13849-1

Electronic devices							
Code/series	Article description	MTTF <sub>D</sub>	DC	PFH <sub>D</sub>	SIL CL	PL	Cat
CS AM-01	Safety module for standstill monitoring	218	Medium	8.70E-09	2	d	3
CS AR-01, CS AR-02	Safety modules for monitoring guards and emergency stops	227	High	1.18E-10	3	e	4
CS AR-04	Safety module for monitoring guards and emergency stops	152	High	1.84E-10	3	e	4
CS AR-05, CS AR-06	Safety modules for monitoring guards, emergency stops and light barriers	152	High	1.84E-10	3	e	4
CS AR-07	Safety module for monitoring guards and emergency stops	111	High	7.56E-10	3	e	4
CS AR-08	Safety module for monitoring guards, emergency stops and light barriers	1547	High	9.73E-11	3	e	4
CS AR-20, CS AR-21	Safety modules for monitoring guards and emergency stops	225	High	4.18E-10	3	e	3
CS AR-22, CS AR-23	Safety modules for monitoring guards and emergency stops	151	High	5.28E-10	3	e	3
CS AR-24, CS AR-25	Safety modules for monitoring guards and emergency stops	113	High	6.62E-10	3	e	3
CS AR-40, CS AR-41	Safety modules for monitoring guards and emergency stops	225	High	4.18E-10	2	d	2
CS AR-46	Safety module for monitoring guards and emergency stops	435	-	3.32E-08	1	c	1
CS AR-51	Safety module for monitoring safety mats and safety bumpers	212	High	3.65E-09	3	e	4
CS AR-90	Safety module for monitoring floor leveling in lifts	382	High	5.03E-10	3	e	4
CS AR-91	Safety module for monitoring floor leveling in lifts	227	High	1.18E-10	3	e	4
CS AR-93	Safety module for monitoring floor leveling in lifts	227	High	1.34E-10	3	e	4
CS AR-94	Safety module for monitoring floor leveling in lifts	227	High	1.13E-10	3	e	4
CS AR-95	Safety module for monitoring floor leveling in lifts	213	High	5.42E-09	3	e	4
CS AT-0•, CS AT-1•	Safety modules with timer for monitoring guards and emergency stops	88	High	1.23E-08	3	e	4
CS AT-3•	Safety module with timer for monitoring guards and emergency stops	135	High	1.95E-09	3	e	4
CS DM-01	Safety module for monitoring two-hand controls	142	High	2.99E-08	3	e	4
CS DM-02	Safety module for monitoring two-hand controls	206	High	2.98E-08	3	e	4
CS DM-20	Safety module for monitoring two-hand controls	42	-	1.32E-06	1	c	1
CS FS-1•	Safety timer module	404	High	5.06E-10	3	e	4
CS FS-2•, CS FS-3•	Safety timer modules	205	High	1.10E-08	2	d	3
CS FS-5•	Safety timer module	379	Medium	1.31E-09	2	d	3
CS ME-01	Contact expansion module	91	High	5.26E-10	①	①	①
CS ME-02	Contact expansion module	114	High	4.17E-10	①	①	①
CS ME-03	Contact expansion module	152	High	3.09E-10	①	①	①
CS ME-20	Contact expansion module	114	High	6.14E-10	①	①	①
CS ME-31	Contact expansion module	110	High	4.07E-09	①	①	①
CS M•201	Multifunction safety modules	135	High	1.44E-09	3	e	4
CS M•202	Multifunction safety modules	614	High	1.32E-09	3	e	4
CS M•203	Multifunction safety modules	103	High	1.61E-09	3	e	4
CS M•204	Multifunction safety modules	134	High	1.52E-09	3	e	4
CS M•205	Multifunction safety modules	373	High	2.19E-09	3	e	4
CS M•206	Multifunction safety modules	3314	High	1.09E-09	3	e	4
CS M•207	Multifunction safety modules	431	High	7.08E-09	3	e	4
CS M•208	Multifunction safety modules	633	High	7.02E-09	3	e	4
CS M•301	Multifunction safety modules	128	High	1.88E-09	3	e	4
CS M•302	Multifunction safety modules	535	High	1.57E-09	3	e	4
CS M•303	Multifunction safety modules	485	High	1.76E-09	3	e	4
CS M•304	Multifunction safety modules	98	High	2.05E-09	3	e	4
CS M•305	Multifunction safety modules	535	High	1.57E-09	3	e	4
CS M•306	Multifunction safety modules	100	High	1.86E-09	3	e	4
CS M•307	Multifunction safety modules	289	High	8.38E-09	3	e	4
CS M•308	Multifunction safety modules	548	High	7.27E-09	3	e	4
CS M•309	Multifunction safety modules	496	High	7.46E-09	3	e	4
CS M•310	Multifunction safety modules	288	High	3.46E-09	3	e	4
CS M•311	Multifunction safety modules	363	High	7.52E-09	3	e	4
CS M•312	Multifunction safety modules	380	High	8.20E-09	3	e	4
CS M•401	Multifunction safety modules	434	High	1.73E-09	3	e	4
CS M•402	Multifunction safety modules	478	High	7.24E-09	3	e	4
CS M•403	Multifunction safety modules	438	High	7.42E-09	3	e	4
CS M•406	Multifunction safety modules	473	High	1.54E-09	3	e	4

B<sub>100</sub>: Number of operations after which 10% of the components have failed dangerously

B<sub>10</sub>: Number of operations after which 10% of the components have failed

B<sub>10</sub>/B<sub>100</sub>: ratio of total failures to dangerous failures.

MTTF<sub>D</sub>: Mean Time To Dangerous Failure

DC: Diagnostic Coverage

PFH<sub>D</sub>: Probability of Dangerous Failure per hour

SIL CL: Safety Integrity Level Claim Limit. Maximum achievable SIL according to EN 62061

PL: Performance Level. PL acc. to EN ISO 13849-1

① = Depending on the base module

**EXAMPLE 1****Application: Guard monitoring**

Reference standard EN ISO 13849-1

Safety category

**1**

Performance Level

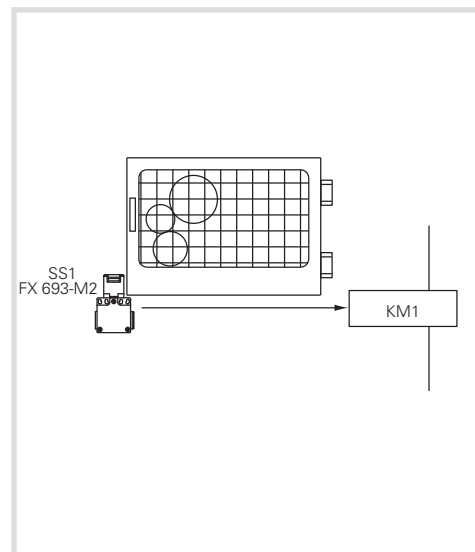
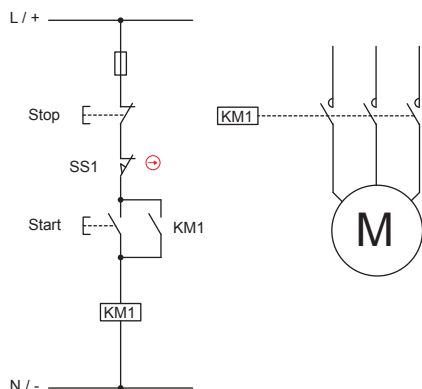
**PL c****Description of the safety function**

The control circuit illustrated above has a guard monitoring function. If the guard is open the engine must not be able to start. The hazard analysis showed that the system has no inertia or rather that the engine, once the power has been switched off, stops at a much faster rate than the opening of the guard. The risk analysis has shown that the required  $PL_r$  target is PL c. This is necessary to verify if the intended control circuit with single channel structure is provided with a PL higher or equal to  $PL_r$ .

The guard position is detected by the switch with separate actuator SS1, which operates directly on the contactor KM1. The contactor KM1 monitoring the moving parts is usually activated by the Start and Stop buttons. Though, the analysis of the working cycle has shown that the guard is opening at every switching operation too. Therefore, the number of switch operations by the contactor and by the safety switch can be considered equal.

A circuit structure is defined as single-channel without supervision (category B or 1) if there are only an Input component (switch) and an Output (contactor) component.

In case a failure on one of the two devices the safety function is not guaranteed anymore.

No measures for fault detection have been applied.

**Device data:**

- SS1 (FX 693-M2) is a switch with positive opening (in accordance with EN 60947-5-1, Annex K). The switch is a well-tried component according to EN ISO 13849-2 table D.4. The  $B_{10D}$  value of the device supplied by the manufacturer is equal to 2,000,000 switching operations.
- KM1 is a contactor operated at nominal load and is a well-tried component in compliance with EN ISO 13849-2, table D.4. The  $B_{10D}$  value of this component is equal to 1,300,000 switching operations. This value results from the tables of the applicable standard (see EN ISO 13849-1, table C.1).

**Assumption of the frequency of use**

- It is assumed that the equipment is used for a maximum of 365 days per year, for three shifts of 8 hours and 600 s cycle time. For the switch, the number of switching operations per year is equal to maximum  $N_{op} = (365 \times 24 \times 3,600) / 600 = 52,560$ .
- It is assumed that the start button is operated every 300 seconds. Therefore, the maximum number of switching operations per year is equal to  $n_{op}/year = 105,120$
- The contactor KM1 is actuated both for the normal start-stop of the machine as well as for the restart after a guard opening.  
 $n_{op}/year = 52,560 + 105,120 = 157,680$

**MTTF<sub>d calculation</sub>**

The  $MTTF_d$  of the SS1 switch is equal to:  $MTTF_d = B_{10D} / (0,1 \times n_{op}) = 2,000,000 / (0,1 \times 52560) = 381$  years

The  $MTTF_d$  of the KM1 contactor is equal to:  $MTTF_d = B_{10D} / (0,1 \times n_{op}) = 1,300,000 / (0,1 \times 157680) = 82$  years

Therefore, the  $MTTF_d$  of the single-channel circuit is equal to:  $1 / (1/381 + 1/82) = 67$  years

**Diagnostic Coverage DCavg**

No measures for fault detection have been applied and there is therefore no diagnostic coverage, a permissible condition for the circuit in question that is in category 1.

**CCF Common Cause Failures**

The CCF calculation is not required for category 1 circuits.

**PL determination**

Using the graph or the figure no. 5 of the standard, it can be verified that for a Category 1 circuit with  $MTTF_d = 95$  years the resulting PL of the control circuit is PL c. The  $PL_r$  target is therefore achieved.

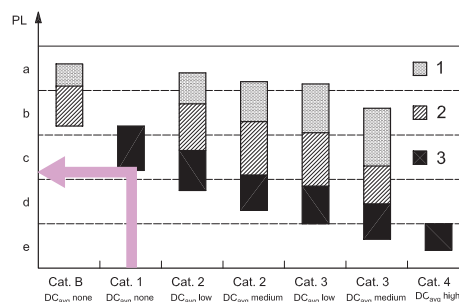



**EXAMPLE 2****Application: Emergency stop control**

Reference standard EN ISO 13849-1

Safety category

**3**

Performance Level

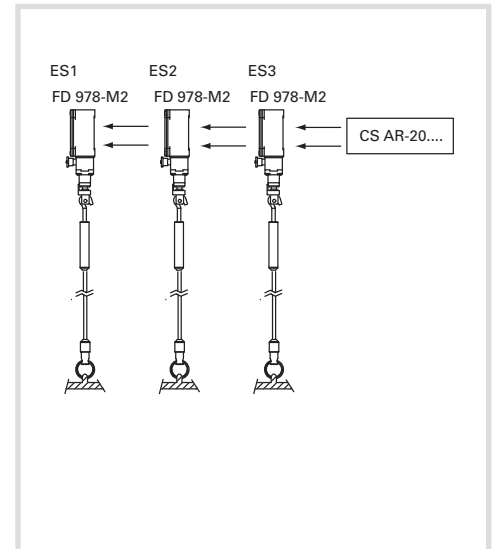
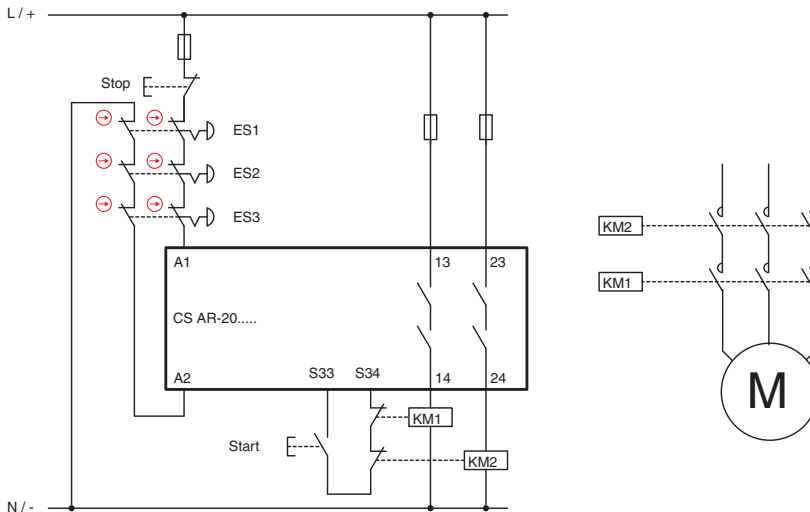
**PL e****Description of the safety function**

The operation of one of the emergency devices causes the intervention of the safety module and the two contactors KM1 and KM2. The signal of the devices ES1, ES2, ES3 is redundantly read by the CS safety module. The contactors KM1 and KM2 (with forcibly guided contacts) are monitored by the CS via the feedback circuit too.

**Device data:**

- The devices ES1, ES2, ES3 (FD 978-M2) are rope switches for emergency stop with positive opening. The  $B_{10D}$  value is 2,000,000
- KM1 and KM2 are contactors operated at nominal load. The  $B_{10D}$  value is 1,300,000 (see EN ISO 13849-1 - Table C.1)
- CS is a safety module (CS AR-20) with  $MTTF_D = 225$  years and DC High
- The circuit structure is two-channel in category 3

**Assumption of the frequency of use**

- Twice a month,  $n_{op}/year = 24$
- Start button actuation: 4 times a day
- Assuming 365 working days, the contactors will take action  $4 \times 365 + 24 = 1484$  times / year
- The switches will be operated with the same frequency.
- It is not expected that multiple buttons will be pressed simultaneously.

**MTTF<sub>d calculation</sub>**

- $MTTF_{D, ES1, ES2, ES3} = 833,333$  years
- $MTTF_{D, KM1, KM2} = 8760$  years
- $MTTF_{D, CS} = 225$  years
- $MTTF_{D, ch1} = 219$  years. The value must be limited to 100 years. The channels are symmetric, therefore  $MTTF_D = 100$  years (High)

**Diagnostic Coverage DC<sub>avg</sub>**

- The contacts of KM1 and KM2 are monitored by the CS module via the feedback circuit. DC = 99% (High)
- The safety module CS AR-20 is provided with a "High" diagnostic coverage.
- Not all failures in the series of emergency devices can be detected. The diagnostic coverage is 90% (Medium)

**CCF Common Cause Failures**

We assume a score > 65 (acc. to EN ISO 13849-1 - Annex F).

**PL determination**

A circuit in category 3 with  $MTTF_D = \text{High}$  and  $DC_{avg} = \text{High}$  can reach a PL e.

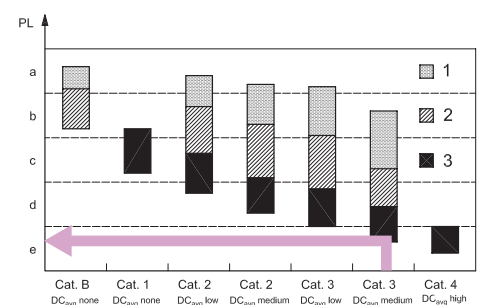

**EXAMPLE 3****Application: Guard monitoring**

Reference standard EN ISO 13849-1

Safety category

**4**

Performance Level

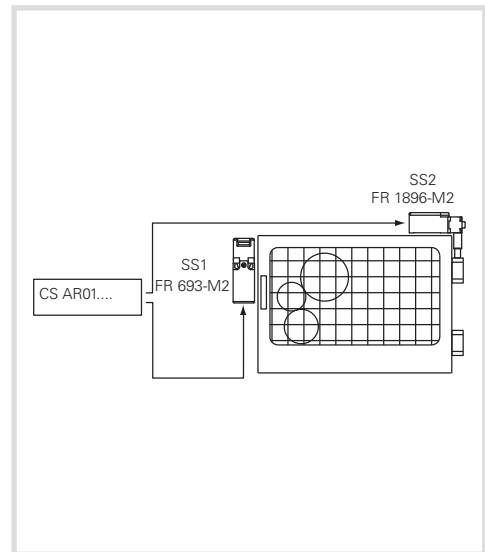
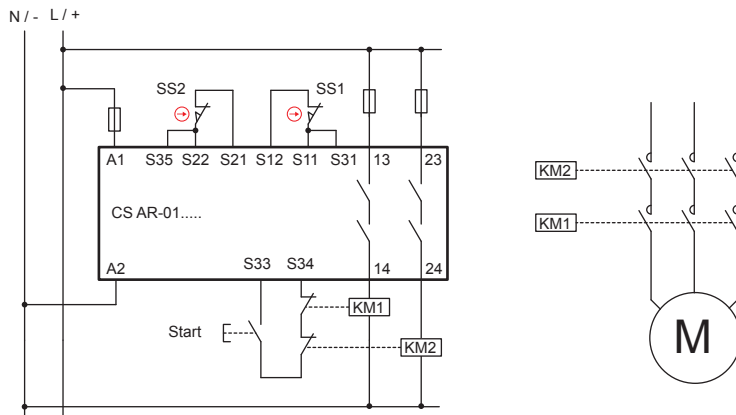
**PL e****Description of the safety function**

The guard opening causes the intervention of the switches SS1 and SS2 and, by consequence, of the safety module and the KM1 and KM2 contactors too.

The signal of the devices SS1 and SS2 is redundantly monitored by the CS safety module.

The switches have different operating principles.

The contactors KM1 and KM2 (with forcibly guided contacts) are monitored by the CS via the feedback circuit too.

**Device data:**

- The switch SS1 (FR 693-M2) is a switch with positive opening. The  $B_{10D}$  value is 2,000,000
  - The switch SS2 (FR 1896-M2) is a hinge switch with positive opening.  $B_{10D} = 5,000,000$
  - KM1 and KM2 are contactors operated at nominal load.  $B_{10D} = 1,300,000$  (see EN ISO 13849-1 - Table C.1)
  - The CS modules are safety modules (CS AR-01) with  $MTTF_d = 227$  years and DC = High
- Assumption of the frequency of use  
365 days/year, 16 h/day, 1 action every 4 minutes (240 s).  $n_{op}/year = 87,600$ .

**MTTF<sub>d calculation</sub>**

- $MTTF_{D_{SS1}} = 228$  years
- $MTTF_{D_{SS2}} = 571$  years
- $MTTF_{D_{KM1,KM2}} = 148$  years
- $MTTF_{D_{CS}} = 227$  years
- $MTTF_{D_{CH1}} = 64$  years (SS1,CS,KM1)
- $MTTF_{D_{CH2}} = 77$  years (SS2,CS,KM2)
- $MTTF_{D}$ : by calculating the average of the two channels  $MTTF_{D} = 70.7$  years (High) is achieved

**Diagnostic Coverage DC<sub>avg</sub>**

- SS1 and SS2 have DC = 99% since the SS1 and SS2 contacts are monitored by CS and have different operation principles.
- The contacts of KM1 and KM2 are monitored by the CS module via the feedback circuit. DC = 99% (High)
- CS AR-01 is provided with an internal redundant and self-monitoring circuit. DC = High
- $DC_{avg} = High$

**PL determination**

A circuit in category 4 with  $MTTF_{D} = 72.1$  years and  $DC_{avg} = High$  corresponds to PL e.

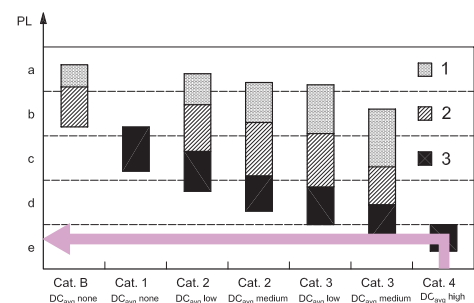

**EXAMPLE 4****Application: Guard monitoring**

Reference standard EN ISO 13849-1

Safety category

**4**

Performance Level

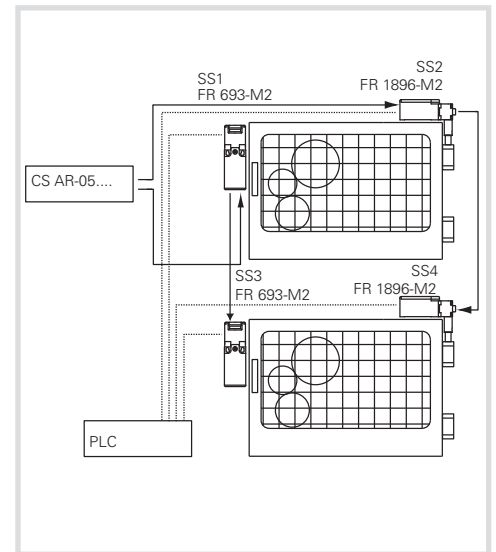
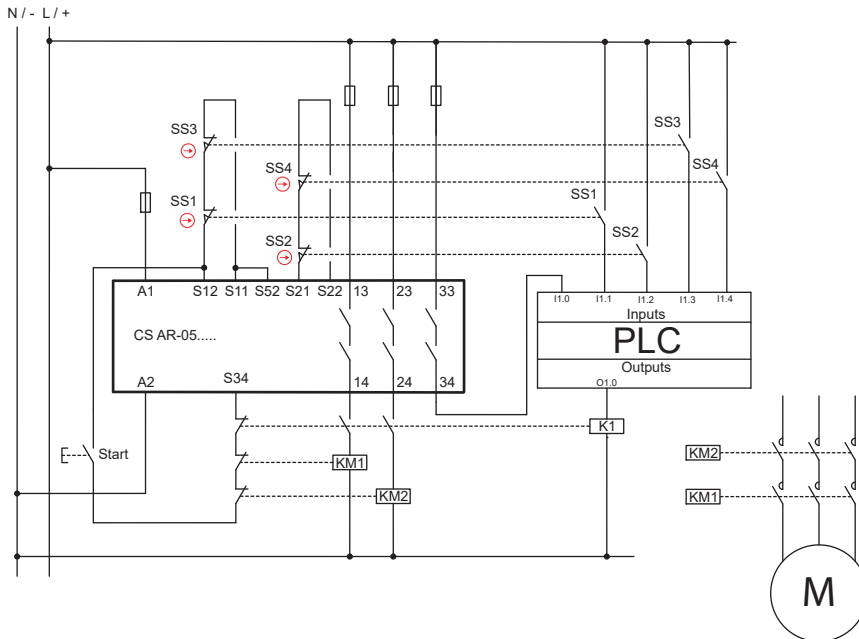
**PL e****Description of the safety function**

The opening of a guard triggers switches SS1 and SS2 on the first guard and triggers SS3, SS4 on the second; the switches trigger the safety module and both contactors KM1 and KM2.

The signal of the devices SS1, SS2 and SS3, SS4 is redundantly monitored by the CS safety module. Furthermore, an auxiliary contact of the switch is monitored by the PLC.

The switches have different operating principles.

The contactors KM1 and KM2 (with forcibly guided contacts) are monitored by the CS via the feedback circuit too.

**Device data:**

- The switches SS1, SS3 (FR 693-M2) are switches with positive opening. The  $B_{10D}$  value is 2,000,000
- The switches SS2, SS4 (FR 1896-M2) are hinge switches with positive opening.  $B_{10D} = 5,000,000$
- KM1 and KM2 are contactors operated at nominal load. The  $B_{10D}$  value is 1,300,000 (see EN ISO 13849-1 - Table C.1)
- CS is a safety module (CS AR-05) with  $MTTF_D = 152$  years and DC = High

**Assumption of the frequency of use**

- 4 times per hour for 24 h/day for 365 days/year equal to  $n_{op}/year = 35,040$
- The contactors will operate for twice the number of operations = 70,080

**MTTF**

- $MTTF_{D, calculation} = 571$  years;  $MTTF_{D, SS1, SS3} = 1,427$  years
- $MTTF_{D, KM1, KM2} = 185$  years
- $MTTF_{D, CS} = 152$  years
- $MTTF_{D, Ch1} = 73$  years (SS1, CS, KM1) / (SS3, CS, KM1)
- $MTTF_{D, Ch2} = 79$  years (SS2, CS, KM2) / (SS4, CS, KM2)
- $MTTF_D$ : by calculating the average of the two channels  $MTTF_D = 76$  years (High) is achieved

**Diagnostic Coverage DC<sub>avg</sub>**

- The contacts of KM1, KM2 are monitored by the CS module via the feedback circuit. DC = 99%
- All auxiliary contacts of the switches are monitored by the PLC. DC = 99%
- The CS AR-05 module has a DC = High
- The diagnostic coverage for both channels is 99% (High)

**CCF Common Cause Failures**

- We assume a score > 65 (acc. to EN ISO 13849-1 - Annex F).

**PL determination**

- A circuit in category 4 with  $MTTF_D = 88.6$  years (High) and  $DC_{avg} = High$  corresponds to PL e.

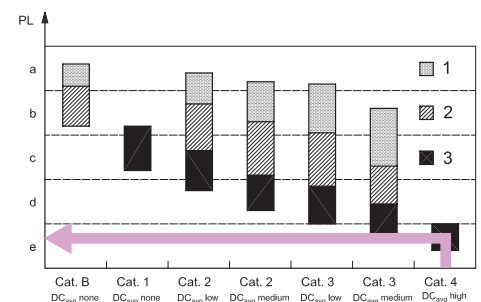

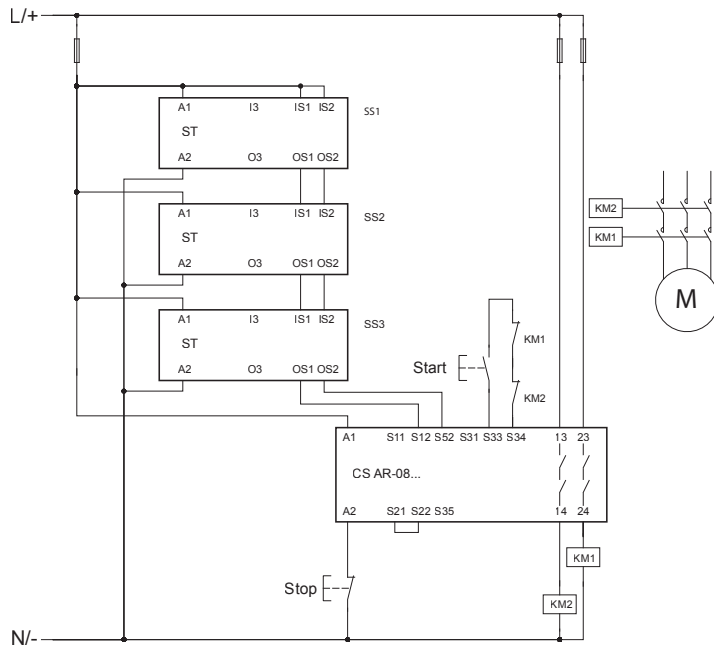
**EXAMPLE 5****Application: Guard monitoring**

Reference standard EN ISO 13849-1

Safety category

**4**

Performance Level

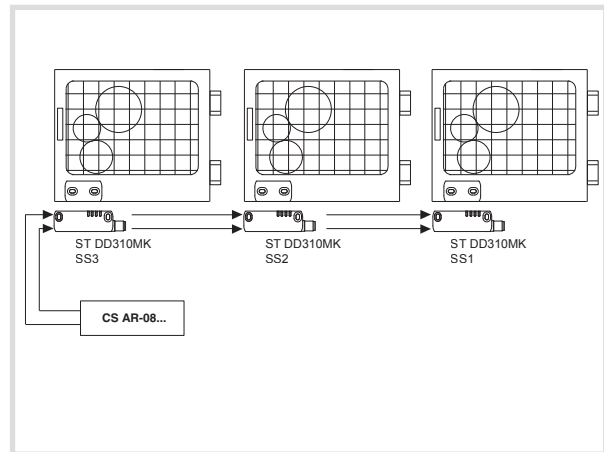
**PL e****Description of the safety function**

The opening of guards triggers the sensors SS1 on the first guard, SS2 on the second and SS3 on the third. The sensors trigger the safety module CS AR-08 and the contactors KM1 and KM2 too. The contactors KM1 and KM2 (with forcibly guided contacts) are monitored by the CS AR-08 via the feedback circuit.

**Device data**

SS1, SS2, SS3 are ST series coded sensors with RFID technology.  $PFH_D = 1.20E-11$ , PL = "e"

CS AR-08 is a safety module.  $PFH_D = 9.73E-11$ , PL = "e"

KM1 and KM2 are contactors operated at nominal load.  $B_{10D} = 1,300,000$  (see EN ISO 13849-1 - Table C.1)

**Assumption of the frequency of use**

Each door is opened every 2 minutes, 16 hours a day, for 365 days a year, equal to  $n_{op} = 175,200$

Definition of the SRP/CS and subsystems

The SRP/CS consists of 5 subsystems (SB):

SB1,2,3 represent the three ST series RFID sensors

SB4 represents the safety module CS AR-08

SB5 represents the two contactors KM1 and KM2 in redundant architecture (cat. 4)

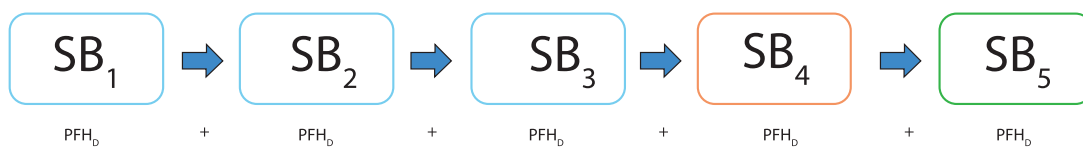
 **$PFH_D$  calculation for SB5**

$MTTF_D$  KM1, KM2 = 74.2 years.

DC = 99%, the contacts of KM1 and KM2 are monitored by the safety module via the feedback circuit.

For the CCF parameter we assume a score higher than 65 (acc. to EN ISO 13849-1 - Annex F).

A category 4 circuit with  $MTTF_D = 74.2$  years (high) and high diagnostic coverage (DC = 99%) corresponds to a failure probability of  $PFH_D = 3.4E-08$  and a PL "e".

**Calculation of the total  $PFH_D$  of the SRP/CS**

$PFH_{DTOT} = PFH_{DSB1} + PFH_{DSB2} + PFH_{DSB3} + PFH_{DSB4} + PFH_{DSB5} = 3.5E-08$

It corresponds to PL "e".

Calculation example performed with SISTEMA software, downloadable free of charge at [www.pizzato.com](http://www.pizzato.com)

**EXAMPLE 6****Application: Guard monitoring**

Reference standard EN ISO 13849-1

Safety category

**4**

Performance Level

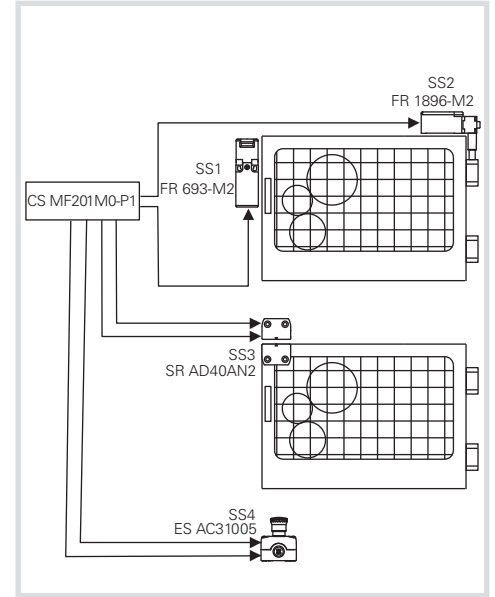
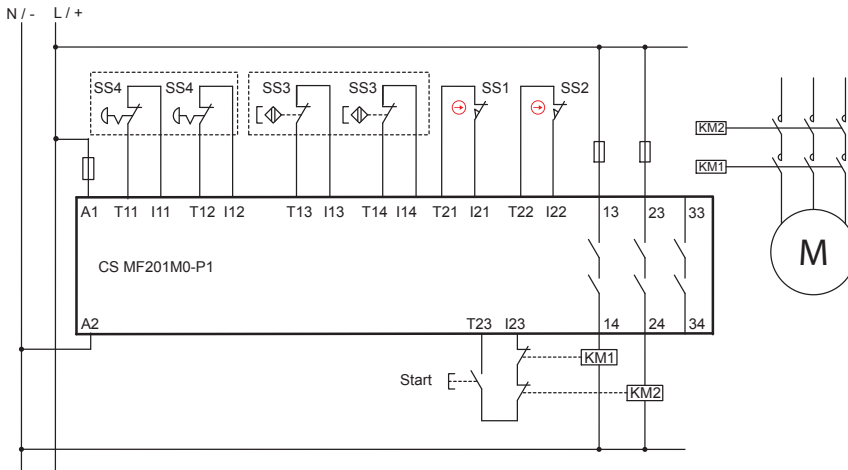
**PL e****Description of the safety function**

The opening of a guard triggers switches SS1 and SS2 on the first guard and triggers sensor SS3 on the second; the switches trigger the safety module and both contactors KM1 and KM2.

The signals from the SS1, SS2 and SS3 devices are redundantly monitored by the CS MF safety module.

There is also an emergency stop button which has a two-channel connection with the safety module too.

The contactors KM1 and KM2 (with forcibly guided contacts) are monitored by the CS MF via the feedback circuit too.

**Device data:**

- The switch SS1 (FR 693-M2) is a switch with positive opening.  $B_{10D} = 2,000,000$
- The switch SS3 (FR 1896-M2) is a hinge switch with positive opening.  $B_{10D} = 5,000,000$
- SS3 (SR AD40AN2) is a magnetic safety sensor.  $B_{10D} = 20,000,000$
- SS4 (ES AC31005) is a housing with emergency stop button (E2 1PERZ4531) provided with 2 NC contacts.  $B_{10D} = 600,000$
- KM1 and KM2 are contactors operated at nominal load.  $B_{10D} = 1,300,000$  (see EN ISO 13849-1 - Table C.1)
- CS MF201M0-P1 is a safety module with  $MTTF_D = 842$  years and  $DC = 99\%$

**Assumption of the frequency of use**

- Each door is opened 2 times per hour for 16 h/day for 365 days/year equal to  $n_{op}/year = 11,680$
- It is assumed that the emergency stop button is actuated at a maximum of once a day,  $n_{op}/year = 365$
- The contactors will operate for twice the number of operations = 23,725

**MTTF<sub>D</sub> calculation****Guard SS1/SS2**

- $MTTF_{D,SS1,SS3} = 1,712$  years
- $MTTF_{D,SS2,SS4} = 4,281$  years
- $MTTF_{D,KM1,KM2} = 548$  years
- $MTTF_{D,CS} = 842$  years
- $MTTF_{D,CH1} = 278$  years (SS1, CS, KM1)
- $MTTF_{D,CH2} = 308$  years (SS2, CS, KM2)
- $MTTF_D =$  by calculating the average of the two channels  $MTTF_D = 293$  years is achieved

**Guard SS3**

- $MTTF_{D,SS3} = 17,123$  years
- $MTTF_{D,KM1,KM2} = 548$  years
- $MTTF_{D,CS} = 842$  years
- $MTTF_D = 325$  years

**Emergency stop button SS4**

- $MTTF_{D,SS4} = 16,438$  years
- $MTTF_{D,KM1,KM2} = 548$  years
- $MTTF_{D,CS} = 842$  years
- $MTTF_D = 325$  years

**Diagnostic Coverage DC<sub>avg</sub>**

- The contacts of KM1, KM2 are monitored by the CS MF module via the feedback circuit.  $DC = 99\%$
- For the devices SS1, SS2 and SS3 it is possible to detect all faults.  $DC = 99\%$
- The CS MF201M0-P1 module has a  $DC = 99\%$
- We assume a diagnostic coverage of 99% (High)

**CCF Common Cause Failures**

- We assume a score > 65 (acc. to EN ISO 13849-1 - Annex F).

**PL determination**

- A circuit in category 4 with  $MTTF_D \geq 30$  years (High) and  $DC_{avg} =$  High corresponds to PL e.
- The safety functions associated to the guards SS1/SS2, SS3 and the emergency stop button present the level PL e.

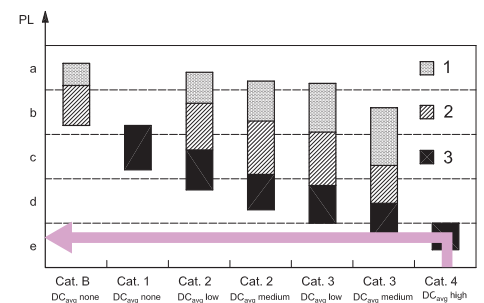

Any information or application example, connection diagrams included, described in this document are to be intended as purely descriptive. The choice and application of the products in conformity with the standards, in order to avoid damage to persons or goods, is the user's responsibility.

**EXAMPLE 7**

**Application: Guard monitoring**

Reference standard EN ISO 13849-1

Safety category

**4**

Performance Level

**PL e**

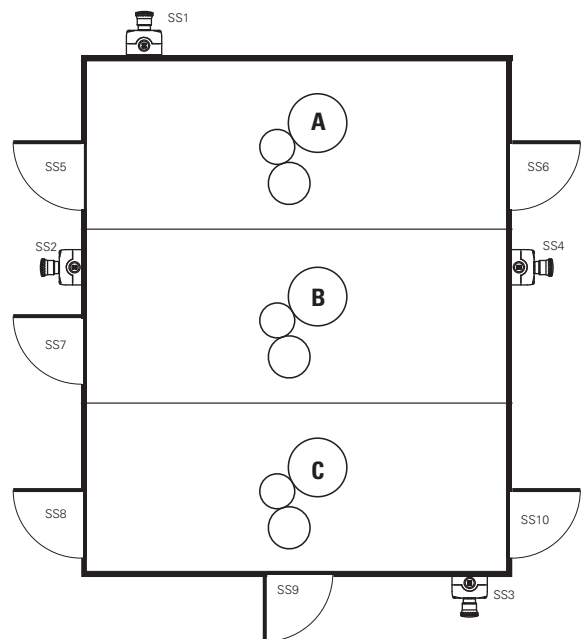
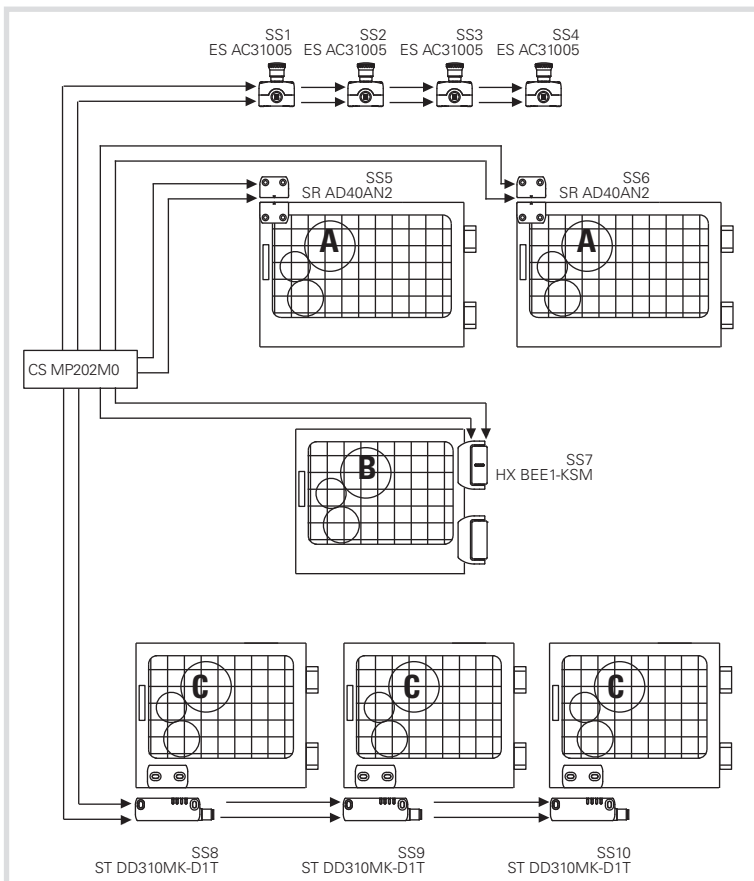
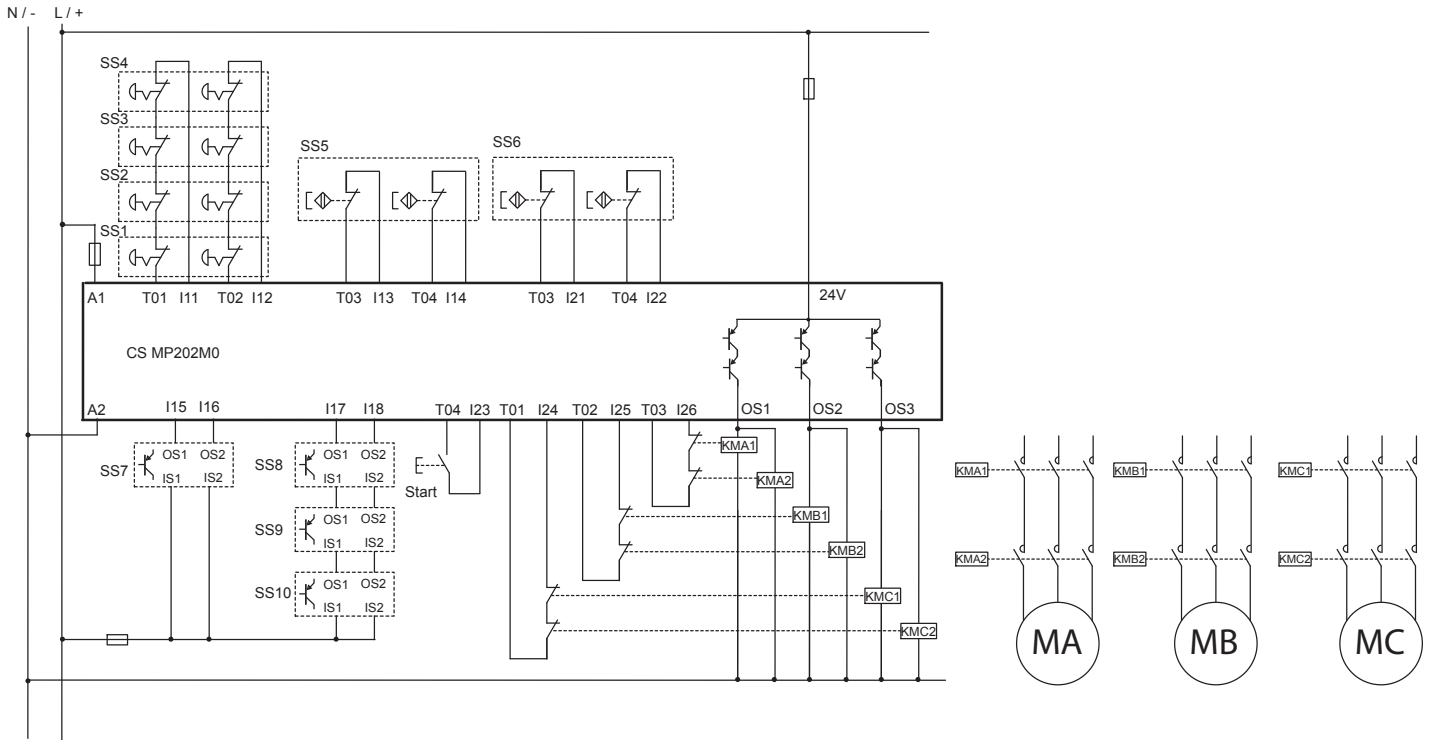

### Description of the safety function

Every machine is divided into 3 different zones. The access to each zone is monitored by the guards and 4 emergency stop buttons are present too.

The operation of an emergency stop button will trigger the CS MP safety module as well as the forcibly guided contactors KMA1/2, KMB1/2 and KMC1/2, and will therefore stop all motors.

The opening of a guard in zone A triggers the devices SS5 or SS6 and, as a consequence, the CS MP safety module as well as the contactors KMA1 and KMA2, and therefore also the stop of the MA motor. The devices SS5 and SS6 are connected to the CS MP safety module separately, with a two-channel connection.

The opening of the guard in zone B triggers the device SS7 and, as a consequence, the CS MP safety module as well as the contactors KMB1 and KMB2, and therefore also the stop of the MB motor. The SS7 hinge is provided with two OSSD outputs and is redundantly controlled by the CS MP safety module.

The opening of a guard in zone C triggers the devices SS8, SS9 or SS10 and, as a consequence, the safety module as well as the contactors KMC1 and KMC2, and therefore also the stop of the MC motor. The sensors SS8, SS9 and SS10 are interconnected via the OSSD outputs and are redundantly monitored by the CS MP safety module.

### Device data

- SS1, SS2, SS3 and SS4 (ES AC31005) are emergency stop buttons (E2 1PERZ4531) provided with 2 NC contacts.  $B_{10D} = 600,000$
- SS5 and SS6 (SR AD40AN2) are magnetic safety sensors.  $B_{10D} = 20,000,000$
- SS7 (HX BEE1-KSM) is a safety hinge with OSSD outputs.  $MTTF_D = 4,077$  years / DC = 99%
- SS8, SS9 and SS10 (ST DD310MK-D1T) are safety sensors with RFID technology and OSSD outputs.  $MTTF_D = 4,077$  years / DC = 99%
- KMA, KMB and KMC are contactors operated at nominal load.  $B_{10D} = 1,300,000$  (see EN ISO 13849-1 - Table C.1)
- CS MP202M0 is a safety module with  $MTTF_D = 2035$  years / DC = 99%

### Assumption of the frequency of use

- Each door of zone A is opened 2 times per hour for 16 h/day for 365 days/year equal to  $n_{op}/year = 11,680$ . The contactors will operate for twice the number of operations = 23,360
- The door of zone B is opened 4 times per hour for 16 h/day for 365 days/year equal to  $n_{op}/year = 23,360$ . The contactors will operate for a given number of operations = 23,360
- Each door of zone C is opened 1 time per hour for 16 h/day for 365 days/year equal to  $n_{op}/year = 5,840$ . The contactors will operate for a given number of operations = 17,520
- It is assumed that the emergency stop button is actuated at a maximum of once a week,  $n_{op}/year = 52$
- Fault Exclusion: since it is assumed that the pairs of contactors, connected in parallel to the respective safety outputs, are wired permanently within the switching cabinet, the possibility of short-circuit between +24V and the contactors is excluded (see Table D.4, item D.5.2 of EN ISO 13849-2).

### MTTF<sub>d calculation</sub>

#### Emergency stop buttons

- $MTTF_D$  SS1/SS2/SS3/SS4 = 115,384 years
- $MTTF_D$  CS = 2035 years
- $MTTF_D$  KMC1, KMC2 = 742 years
- $MTTF_D$  e-stop = 541 years

#### Guards, zone A

- $MTTF_D$  SS5/SS6 = 17,123 years
- $MTTF_D$  CS = 2035 years
- $MTTF_D$  KMA1, KMA2 = 556 years
- $MTTF_D$  A = 425 years (SS5/SS6, CS, KMA)

#### Guards, zone B

- $MTTF_D$  SS7 = 4,077 years
- $MTTF_D$  CS = 2035 years
- $MTTF_D$  KMB1, KMB2 = 556 years
- $MTTF_D$  B = 394 years (SS7, CS, KMB)

#### Guards, zone C

- $MTTF_D$  SS8/SS9/SS10 = 4,077 years
- $MTTF_D$  CS = 2035 years
- $MTTF_D$  KMC1, KMC2 = 742 years
- $MTTF_D$  C = 479 years (SS8/SS9/SS10, CS, KMC)

### Diagnostic Coverage DC<sub>avg</sub>

- The contacts of KMA, KMB and KMC are monitored by the CS MP module via the feedback circuit. DC = 99%
- All faults in the various devices can be detected. DC = 99%
- The CS MP202M0 module has a DC = 99%
- The result is a diagnostic coverage of 99% for each function

### CCF Common Cause Failures

- We assume a score > 65 for all safety functions (acc. to EN ISO 13849-1 - Annex F).

### PL determination

- A circuit in category 4 with  $MTTF_D \geq 30$  years (High) and  $DC_{avg} =$  High corresponds to PL e.
- All safety functions associated to the guards and the emergency stop buttons have PL e.

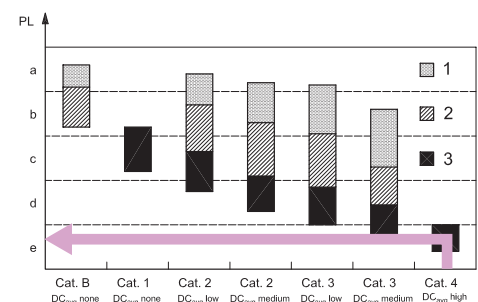

**EXAMPLE 8**

**Application: Guard monitoring**

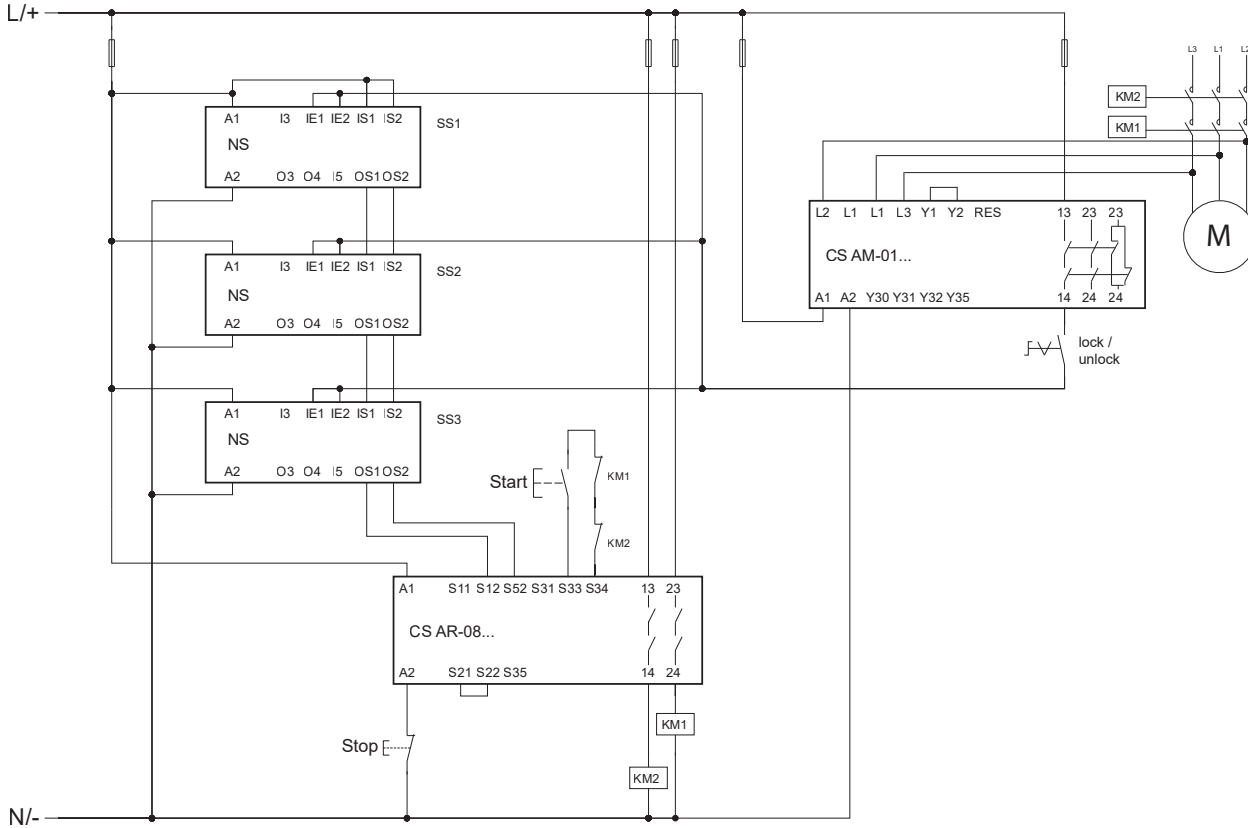

Reference standard EN ISO 13849-1

Performance Level - Safety function 1

**PL e**

Performance Level - Safety function 2

**PL d**

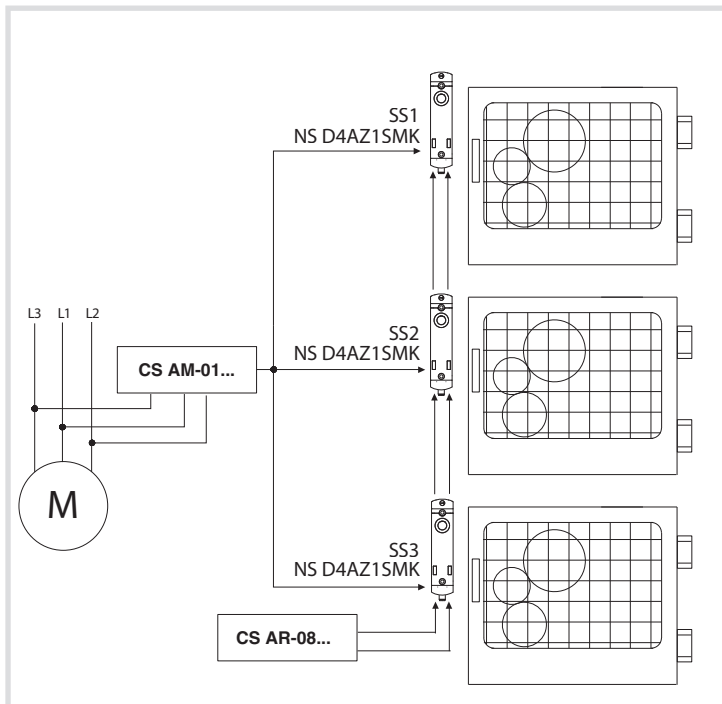



### Description of the safety function

Interlocking devices SS1, SS2 and SS3 perform two safety functions: monitoring the locked state and locking the guard. Once the guards have been released, the three sensors trigger the safety module and the contactors KM1 and KM2 too. The contactors KM1 and KM2 (with forcibly guided contacts) are monitored by the CS AR-08 via the feedback circuit. The interlock command on the three devices SS1, SS2 and SS3 is maintained until the motor standstill monitoring module CS AM-01 detects the actual stopping of movement.

### Device data

SS1, SS2, SS3 are NS series coded interlock devices with RFID technology, with guard locking device. Locked protection detection function  $PFH_D = 1.22E-09$  PL = "e", operating of locking control  $PFH_D = 2.29E-10$  PL = "e"

CS AR-08 is a safety module,  $PFH_D = 9.73 E-11$ , PL = "e"

CS AM-01 is a safety module for motor standstill monitoring,  $PFH_D = 8,70E-09$ , PL "d"

KM1 and KM2 are contactors operated at nominal load.  $B_{10D} = 1,300,000$  (see EN ISO 13849-1 - Table C.1)

### Assumption of the frequency of use

Each door is opened every 10 minutes, 16 hours a day, for 365 days a year, equal to  $n_{op}/year = 35,040$

### Definition of the SRP/CS and subsystems

This application example presents two safety functions:

1. Safety-related stop function initiated by a protective measure
2. Maintain interlock of the guard with motor M in motion

The safety function 1 is performed by an SRP/CS consisting of 5 subsystems (SB):

- SB11,12,13 represent the three RFID interlock devices of the NS series: SS1, SS2 and SS3
- SB14 represents the safety module CS AR-08
- SB15 represents the two contactors KM1 and KM2 in redundant architecture (cat. 4)

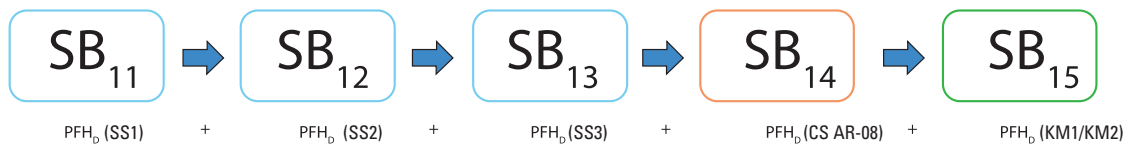

The safety function 2 is performed by 2 subsystems (SB):

- SB21 represents the CS AM-01 safety module for motor standstill monitoring
- SB22 represents the three NS series RFID interlock devices

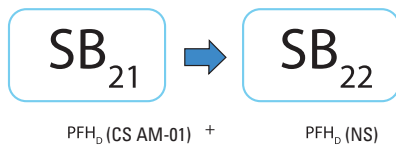

### PFH<sub>D</sub> calculation for SB15

$MTTF_D$  KM1,KM2 = 371 years.

DC = 99%, the contacts of KM1 and KM2 are monitored by the safety module via the feedback circuit.

For the CCF parameter we assume a score higher than 65 (acc. to EN ISO 13849-1 - Annex F).

A category 4 circuit with  $MTTF_D = 371$  and high diagnostic coverage (DC = 99%) corresponds to a failure probability of  $PFH_D = 6.3E-09$  and a PL "e".

### Calculation of the total PFH<sub>D</sub> of the SRP/CS safety function 1 (interlock)

$PFH_{DTOT} = PFH_{DSB11} + PFH_{DSB12} + PFH_{DSB13} + PFH_{DSB14} + PFH_{DSB15} = 1E-08$

It corresponds to PL "e".

### Calculation of the total PFH<sub>D</sub> of the SRP/CS safety function 2 (lock)

$PFH_{DTOT} = PFH_{DSB21} + PFH_{DSB22} = 8.9E-09$

That would correspond to PL "e". However, considering that the motor standstill monitoring module is characterised by a PL "d", and that the unlock command takes place via a single-channel architecture, the entire SRP/CS is downgraded to this value, therefore PL "d".

Calculation example performed with SISTEMA software, downloadable free of charge at [www.pizzato.com](http://www.pizzato.com)

**EXAMPLE 9**

**Application: Guard monitoring**

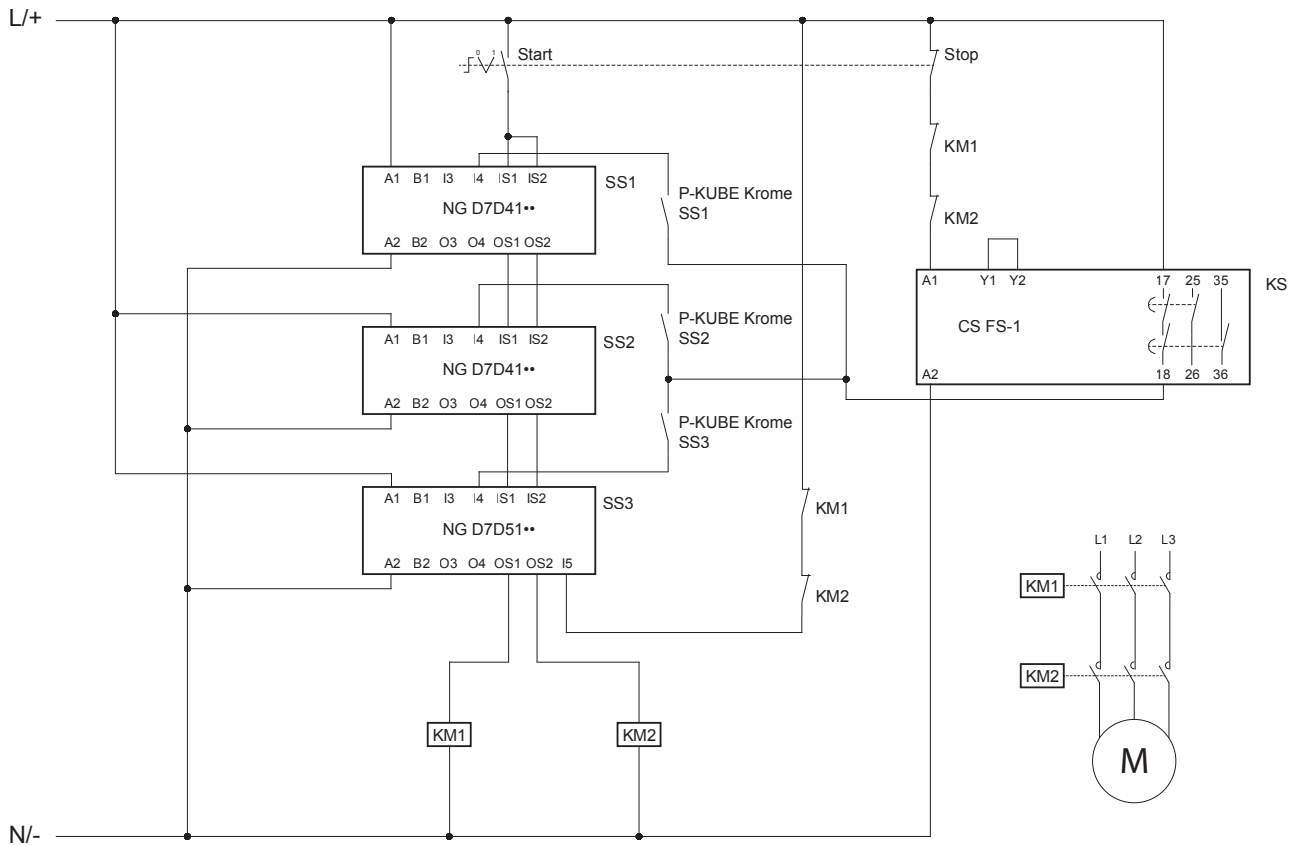

Reference standard EN ISO 13849-1

Performance Level - Safety function 1

Performance Level - Safety function 2

**PL e**

**PL d**

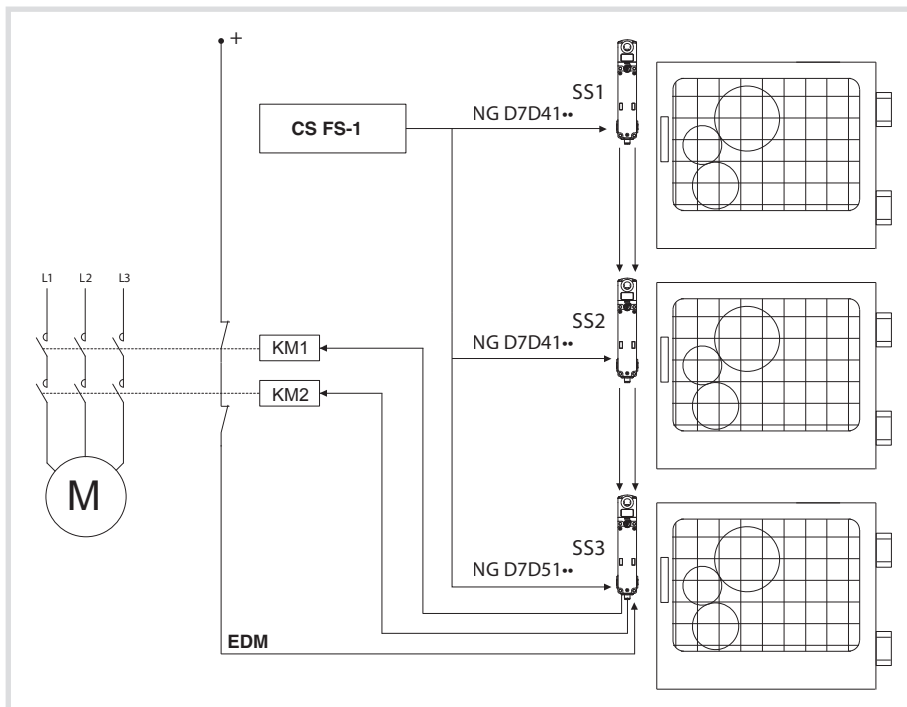

### Description of the safety function

Interlocking devices SS1, SS2 and SS3 perform two safety functions: monitoring the locked state and locking the guard. Once the guards have been released, the three sensors act directly on contactors KM1 and KM2. Contactors KM1 and KM2 (with forcibly guided contacts) are controlled by the SS3 sensor, via EDM (External Device Monitoring) input I5. The interlock command on the three devices SS1, SS2 and SS3 depends on the closure of the safe contact of a CS FS-1 safety timer module. Each device will receive the unlock command, when the button mounted on the P-KUBE Krome handle is pressed.

### Device data

SS1, SS2, SS3 are coded interlock devices with RFID technology, with guard locking device. Locked protection detection function  $PFH_d = 1,17E-09$  PL = "e"; single channel locking control function  $PFH_d = 1,51E-10$  PL = "d".

CS FS-1 is a safety timer module,  $PFH_d = 5.06E-10$ , PL "e".

KM1 and KM2 are contactors operated at nominal load.  $B_{10D} = 1,300,000$  (see EN ISO 13849-1 - Table C.1)

### Assumption of the frequency of use

Each door is opened every 10 minutes, 16 hours a day, for 365 days a year, equal to  $n_{op} = 35,040$

### Definition of the SRP/CS and subsystems

This application example presents two safety functions:

1. Safety-related stop function initiated by a protective measure
2. Maintain interlock of the guard with motor M1 in motion

The safety function 1 is performed by an SRP/CS consisting of 4 subsystems (SB):

- SB11,12,13 represent the three RFID interlock devices of the NG series: SS1, SS2 and SS3
- SB14 represents the two contactors KM1 and KM2 in redundant architecture (cat. 4)

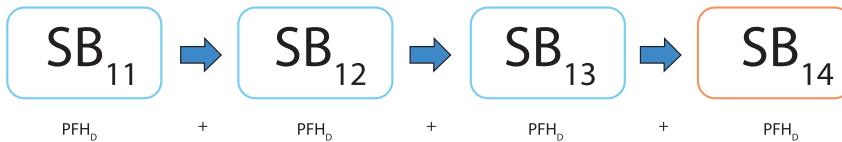

The safety function 2 is performed by 2 subsystems (SB):

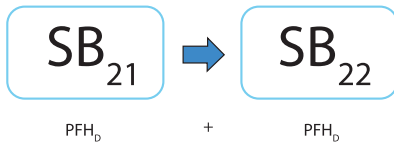

- SB21 represents the safety timer module CS FS-1

- SB22 represents the NG series RFID interlocking device

### PFH<sub>b</sub> calculation for SB14

$MTTF_D$  KM1,KM2 = 371 years.

DC = 99%, the KM1 and KM2 contacts are monitored by the last NG device in the series, via the EDM input.

For the CCF parameter we assume a score higher than 65 (acc. to EN ISO 13849-1 - Annex F).

A category 4 circuit with  $MTTF_D = 371$  and high diagnostic coverage (DC = 99%) corresponds to a failure probability of  $PFH_D = 6.3E-09$  and a PL "e".

### Calculation of the total PFH<sub>b</sub> of the SRP/CS safety function 1

$PFH_{DTOT} = PFH_{DSB11} + PFH_{DSB12} + PFH_{DSB13} + PFH_{DSB14} = 9.8E-09$

It corresponds to PL "e".

### Calculation of the total PFH<sub>b</sub> of the SRP/CS safety function 2

$PFH_{DTOT} = PFH_{DSB21} + PFH_{DSB22} = 6.6E-10$

That would correspond to PL "e". Considering however, that the NG device with single channel interlock command is characterized by a PL "d"; the entire SRP/CS is downgraded to this value; therefore PL "d".

## Definitions according to the EN 60947-1 and EN 60947-5-1 standards

### Control switches

Devices or operating mechanisms for controlling the operation of equipment, including signalling, interlocking, etc.

### Utilization category

Combination of specified requirements related to the conditions in which the switching device fulfils its purpose.

### Operating cycle

Sequence of two operations, one for opening and one for closing.

### Rated current $I_e$

This current depends on the rated operating voltage, the rated frequency, the utilization category and the type of protective enclosure, if present.

### Thermal current $I_{th}$

Maximum current for heating tests on equipment without enclosure, in free air. Its value shall be least to equal to the maximum value of the rated operational current  $I_e$  of the equipment without enclosure, in eight-hour duty.

### Electrical endurance

Number of on-load operating cycles, under the conditions defined by the corresponding product standard, which can be carried out without repair or replacement.

### Mechanical endurance

Number of no-load operating cycles (i.e. without current on the main contacts), under the conditions defined by the corresponding product standard, which can be carried out without repair or replacement of mechanical parts.

### Contact elements

The parts, fixed or movable, conducting or insulating, of a control switch necessary to close and open one single conducting path of a circuit.

### Single interruption contact elements

Contact element opening or closing the circuit's conducting path at one point only.

### Double interruption contact elements

Contact element opening or closing the circuit's conducting path at two points in series.

### Make-contact elements (normally open)

Contact element closing a circuit's conducting path when the control switch is actuated.

### Break-contact elements (normally closed)

Contact element opening a circuit's conducting path when the control switch is actuated.

### Change-over contact elements

Contact element combination including one make-contact element and one break-contact element.

### Electrically separated contact elements

Contact elements of the same control switch which are well isolated from each other and therefore can be connected to electric circuits with different voltages.

### Contact elements with independent action (snap action)

Contact element of a manual or automatic device for control circuits where the motion speed of the contact is substantially independent from the motion speed of the actuator.

### Contact elements with dependent action (slow action)

Contact element of a manual or automatic device for control circuits where the motion speed of the contact depends on the motion speed of the actuator.

### Minimum actuating force

Minimum force to be applied to the actuator that will cause all contacts to reach their switched position.

### Position switch

Control switch whose controller is actuated by a moving part of the machine, when this part arrives to a set position.

### Foot switch

Control switch whose actuator is actuated by exerting force with a foot on the pedal.

### Pre-travel of the actuator

The maximum travel of the actuator which does not cause any travel of the contact elements.

### Ambient temperature

The air temperature surrounding the complete switching device, under prescribed conditions.

### Rated operating voltage $U_e$

Voltage which, combined with the rated operational current  $I_e$ , determinates the application of the equipment and the referred utilization categories.

### Rated insulation voltage $U_i$

Reference voltage for the dielectric test voltage and the creepage distances along surfaces.

### Rated impulse withstand voltage $U_{imp}$

The highest peak value of an impulse voltage, of a prescribed shape and polarity, which does not cause destructive discharge under the specified test conditions.

### Contact block

Contact element or contact elements combination which can be combined with similar units, operated by a common actuating system.

## Markings and quality marks

### CE marking



The CE marking is a mandatory declaration made by the manufacturer of a product in order to indicate that the product satisfies all requirements foreseen by the directives (regulated by the European Community) in terms of safety and quality. Therefore, it ensures National bodies of the EU countries about the fulfilment of obligations laid down in the agreements.

### IMQ mark



The IMQ (Italian Institute of the Quality Mark) is an association in Italy (independent third body) whose task is to check and certify the compliance of materials and equipment with safety standards (CEI standards in the electric and electronic sector). This voluntary conformity certification is a guarantee of quality, safety and technical value.

### UL mark



UL (Underwriters Laboratories Inc.) is an independent non-profit body that tests materials, devices, products, equipment, constructions, methods and systems with regard to their risk for human life and goods according to the standard in force in the United States and Canada. Decisions made by UL are often recognized by many governing authorities concerning the compliance with local safety regulations.

### CCC mark



The CQC is the organization in the Chinese Popular Republic whose task is to check and certify the low voltage electrical material. This organization issues the product mark CCC which certifies the passing of electrical/mechanical conformity tests by products and the compliance of the company quality system with required standards. To obtain the mark, the Chinese body makes preliminary company visits as well as periodical check inspections. Position switches cannot be sold in the Chinese territory without this mark.

### TÜV SÜD mark



TÜV SÜD is an international authority claiming long-standing experience in the certification of operating safety for electrical, electromechanical and electronic products. In the course of type approval, TÜV SÜD closely inspects the quality throughout all the stages concerning product development, from software design and completion, to production and to the tests conducted according to ISO/IEC standards. The operating safety certification is obtained voluntarily and has a high technical value, since it not only certifies the electrical safety of the product, but also its specific operating suitability for use in safety applications according to the IEC 61508 standard.

### EAC mark



The EAC certificate of conformity is a certificate issued by a Customs Union certification body formed by Russia, Belarus and Kazakhstan, with which the conformity of a product is certified with the essential safety requirements laid down by one or more Technical Regulations (Directives) of the Customs Union.

### ECOLAB mark



ECOLAB is one of the world's leading providers of technologies and services for hygiene in food processing. ECOLAB certifies the compatibility of tested electrical devices in its own laboratories, using disinfectants and cleaning agents used in the area of food processing worldwide.

### UKCA mark



Following the withdrawal of the United Kingdom from the European Union, the UKCA mark (UKCA Conformity Assessment) takes the place of the CE marking for the British market (England, Scotland and Wales).

The UKCA mark indicates that the product satisfies the British regulations. As in the European Union, conformity can be achieved through the application of harmonised standards, the so-called "designated standards". The evaluation of the conformity can be performed through self-certification or through a certification process by an "approved body". At the time of printing this catalogue, the British government specified 1 January 2025 as the date from which the UKCA mark will be mandatory for products that are placed on the market in Great Britain.

## International and European Standards

**EN 50041:** Low voltage switchgear and controlgear for industrial use. Control switches. Position switches 42.5x80 mm. Dimensions and features.

**EN 50047:** Low voltage switchgear and controlgear for industrial use. Control switches. Position switches 30x55 mm. Dimensions and features.

**EN ISO 14119:** Safety of machinery. Interlocking devices associated with guards. Design and selection principles.

**EN ISO 12100:** Safety of machinery. General design principles. Risk assessment and risk reduction.

**EN ISO 13849-1:** Safety of machinery. Safety-related parts of control systems. Part 1: General principles for design.

**EN ISO 13850:** Safety of machinery. Emergency stop devices, functional aspects. Design principles.

**EN 61000-6-3 (equivalent to IEC 61000-6-3):** Electromagnetic compatibility. Generic emission standard. Part 1: Residential, commercial and light-industrial environments.

**EN 61000-6-2 (equivalent to IEC 61000-6-2):** Electromagnetic compatibility. Generic immunity standard. Part 2: Industrial environments.

**EN ISO 13855:** Safety of machinery. Positioning of safeguards with respect to the approach speeds of parts of the human body.

**EN ISO 14118:** Safety of machinery. Prevention of unexpected start-up.

**EN ISO 13851:** Safety of machinery. Two-hand control devices. Principles for design and choice.

**EN 60947-1 (equivalent to IEC 60947-1):** Low-voltage switchgear and controlgear. Part 1: General rules.

**EN 60947-5-1 (equivalent to IEC 60947-5-1):** Low-voltage switchgear and controlgear. Part 5: Devices for control and operation circuits. Section 1: Electromechanical control circuit devices.

**EN 60947-5-2:** Low-voltage switchgear and controlgear. Part 5-2: Control circuit devices and switching elements - Proximity switches.

**EN 60947-5-3:** Low-voltage switchgear and controlgear. Part 5-3: Control circuit devices and switching elements - Requirements for proximity devices with defined behaviour under fault conditions (PDF).

**EN 60204-1 (equivalent to IEC 60204-1):** Safety of machinery. Electrical equipment of machines. Part 1: General rules.

**EN 60529 (equivalent to IEC 60529):** Protection degree of the housings (IP codes).

**ISO 20653:** Road vehicles-degrees of protection (IP CODE).

**EN 62326-1 (equivalent to IEC 62326-1):** Printed boards. Part 1: Generic specification.

**EN 60664-1 (equivalent to IEC 60664-1):** Insulation coordination for equipment within low-voltage systems. Part 1: Principles, requirements and tests.

**EN 61508 (equivalent to IEC 61508):** Functional safety of electrical, electronic and programmable electronic systems for safety applications.

**EN 62061 (equivalent to IEC 62061):** Safety of machinery - Functional safety of safety-related electrical, electronic and programmable electronic control systems.

**EN 60079-0 (equivalent to IEC 60079-0):** Explosive atmospheres - Part 0: Equipment - General requirements.

**EN 60079-11 (equivalent to IEC 60079-11):** Explosive atmospheres - Part 11: Equipment protection by intrinsic safety "i".

**EN 60079-15 (equivalent to IEC 60079-15):** Explosive atmospheres - Part 15: Equipment protection by type of protection "n".

**EN 60079-31 (equivalent to IEC 60079-31):** Explosive atmospheres - Part 31: Equipment dust ignition protection by enclosure "t".

**EN IEC 63000:** Technical documentation for the evaluation of electrical and electronic products in relation to the restriction of hazardous substances.

**BG-GS-ET-15:** Prescriptions about how to test switches with forced contact opening to be used in safety applications (German standard).

**UL 508:** Standards for industrial control equipment. (American standard).

**CSA C22.2 No. 14:** Standards for industrial control equipment. (Canadian standard).

## European directives

2014/35/EU	Directive on low-voltage switchgear and controlgear
2006/42/EC	Machinery Directive
2014/30/EU	Directive on electromagnetic compatibility
2014/34/EU	ATEX Directive
2011/65/UE	RoHS Directive

## Regulatory Organisations

<b>CEI</b>	Comitato Elettrotecnico Italiano (IT)	<b>NF</b>	Normes Françaises (FR)
<b>CSA</b>	Canadian Standard Association (CAN)	<b>VDE</b>	Verband Deutscher Elektrotechniker (DE)
<b>CENELEC</b>	European Committee for Electrotechnical Standardisation	<b>UNI</b>	Ente Nazionale Italiano di Unificazione (IT)
<b>CEN</b>	European Committee for Standardisation	<b>UL</b>	Underwriter's Laboratories (USA)
<b>IEC</b>	International Electrotechnical Commission	<b>TÜV</b>	Technischer Überwachungs-Verein (DE)

## Protection degree of housings for electrical material according to EN 60529

The following table reports the required protection degrees according to the IEC 60529, EN 60529, CEI 70-1 standards.

The protection degrees are indicated by the abbreviation IP and 2 following digits. 2 additional letters can be reported indicating protection of persons or other features. The first digit shows the degree of protection against penetration of external solid materials. The second digit identifies instead the protection degree against liquid penetration.

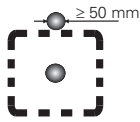
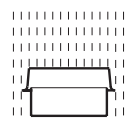
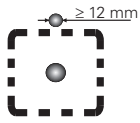
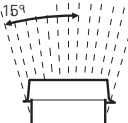
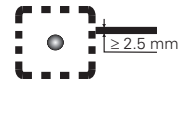
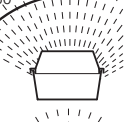
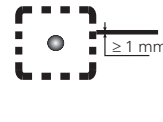
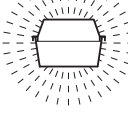
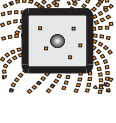
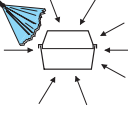
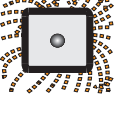
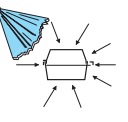
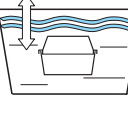
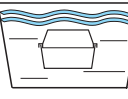
1st digit	Description	Protection for the machine	Protection for persons	2nd digit	Description	Protection for the machine
<b>0</b>		Not protected	Not protected	<b>0</b>		Not protected
<b>1</b>		Protected against solid objects greater than 50 mm	Against access to hazardous parts with the back of a hand (Ø 50 mm)	<b>1</b>		Protected against vertically falling water drops
<b>2</b>		Protected against solid objects greater than 12 mm	Against access to hazardous parts with a finger (Ø 12 mm)	<b>2</b>		Protected against water drops falling at max. 15° angle
<b>3</b>		Protected against solid objects greater than 2.5 mm	Against access to hazardous parts with a tool (Ø 2.5 mm)	<b>3</b>		Protected against rain drops falling at max. 60° angle
<b>4</b>		Protected against solid objects greater than 1 mm	Against access to hazardous parts with a wire (Ø 1 mm)	<b>4</b>		Protected against splash water from any direction
<b>5</b>		Protected against dust	Against access to hazardous parts with a wire (Ø 1 mm)	<b>5</b>		Protected against water jets from any direction
<b>6</b>		Totally protected against dust	Against access to hazardous parts with a wire (Ø 1 mm)	<b>6</b>		Protected against powerful water jets from any direction (e.g. waves)
				<b>7</b>		Protected against temporary water immersion (30 minutes at one-meter depth)
				<b>8</b>		Protected against continuous immersion in water

## Protection degree IP69K according to ISO 20653

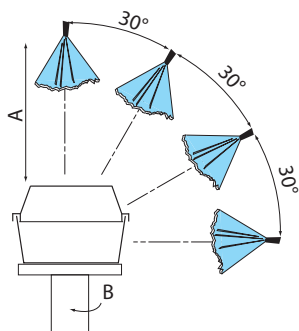

ISO 20653 envisages a particularly strenuous test. This test simulates the conditions of pressure washing in industrial environments with water jets having pressure between 80 and 100 bar, flow rate between 14 and 16 l/min. and a temperature of 80°C.

Test specifications:

Rotation speed (B):	5 ± 1 rpm
Distance from water jet (A):	100 +50/-0 mm
Water flow rate:	15 ± 1 l/min
Water pressure:	9000 ± 1000 kPa
Water temperature:	80 ± 5 °C
Test duration:	30 s per position

## Housing data in accordance with UL (UL 508) and CSA (C22-2 no.14) approvals

The features required for a housing are determined by a specific environmental designation and other features such as the kind of gasket or the use of solvent materials.

Type	Intended use and description
1	Mainly for indoor utilization, supplied with protection against contact with the internal mechanism and against a limited quantity of falling dirt.
4X	Suitable for both indoor and outdoor use, provided with protection degree against falling rain, water splashes and direct coming water from a pipe. No damage caused by ice formation on the housing. Corrosion-resistant.
12	Indoor utilization, provided with a protection degree against dust, dirt, flying fibres, dripping water and outside condensation of non-corrosive fluids.
13	Indoor utilization, supplied with a protection degree against gauze, dust penetration, outside condensation and sprinkling of water, oil and non-corrosive fluids.

## Pollution degree (of environmental conditions) according to EN 60947-1

According to the EN 60947-1 standard, the pollution degree is a conventional number based on the quantity of conducting hygroscopic dust, ionized gas or salt, and on the relative humidity and its frequency of occurrence resulting in hygroscopic absorption or condensation of moisture leading to reduction in dielectric strength and/or surface resistivity. In equipment to be used inside a housing or having an integral enclosure as part of the device, the pollution degree applies to the inner part of housing. With the purpose of evaluating the air and surface insulation distances, the following four pollution degrees are defined:

Degree	Description
1	No pollution or only dry and non-conductive pollution occurs.
2	Normally, only non-conductive pollution is present. Occasionally some temporary conductivity caused by condensation may occur.
3	Some conductive pollution is present, or some dry non-conductive pollution that becomes conductive because of condensation.
4	Pollution causes persistent conductivity, for instance due to conductive dust or rain or snow.

Where not otherwise specified by the applicable standards for the product, equipment for industrial applications are generally intended for their use in environment with pollution degree 3. Nevertheless, other degrees can be considered, depending on the micro-environment or on particular applications.

## Use in alternating and direct current of auxiliary devices acc. to EN 60947-5-1

Alternating current use		Direct current use	
Utilization category	Intended use	Utilization category	Intended use
AC12	Control of resistive loads and solid state loads with insulation by optocouplers.	DC12	Control of resistive loads and solid state loads with insulation by optocouplers.
AC13	Control of solid state loads with transformer isolation.	DC13	Control of electromagnetic loads without economy resistors in circuit.
AC14	Control of electromagnetic loads, power ≤ 72 VA.	DC14	Control of electromagnetic loads with economy resistors in circuit.
AC15	Control of electromagnetic loads, power ≥ 72 VA.		

Legend:

FA 4101-•DN → NA B110AB-DN•

The codes in grey have been replaced by the code after the arrow

Old Article	New Article	Old Article	New Article	Old Article	New Article
FA 4101-•DN →	NA B110AB-DN•	FA 4550-•DN →	NA B112LE-DN•	FA 4825-•DN →	NA L110HE-DN•
FA 4101-KDM →	NA B110AB-DMK	FA 4550-KDM →	NA B112LE-DMK	FA 4825-KDM →	NA L110HE-DMK
FA 4102-•DN →	NA B110CP-DN•	FA 4551-•DN →	NA B112KE-DN•	FA 4830-•DN →	NA L112KA-DN•
FA 4102-KDM →	NA B110CP-DMK	FA 4551-KDM →	NA B112KE-DMK	FA 4830-KDM →	NA L112KA-DMK
FA 4108-•DN →	NA B110AE-DN•	FA 4552-•DN →	NA B112KF-DN•	FA 4831-•DN →	NA L112KC-DN•
FA 4108-KDM →	NA B110AE-DMK	FA 4552-KDM →	NA B112KF-DMK	FA 4831-KDM →	NA L112KC-DMK
FA 4110-•DN →	NA B110EB-DN•	FA 4554-•DN →	NA B112KG-DN•	FA 4833-•DN →	NA L112LB-DN•
FA 4110-KDM →	NA B110EB-DMK	FA 4554-KDM →	NA B112KG-DMK	FA 4833-KDM →	NA L112LB-DMK
FA 4111-•DN →	NA B110FB-DN•	FA 4555-•DN →	NA B112KP-DN•	FA 4834-•DN →	NA L112LL-DN•
FA 4111-KDM →	NA B110FB-DMK	FA 4555-KDM →	NA B112KP-DMK	FA 4834-KDM →	NA L112LL-DMK
FA 4112-•DN →	NA B110FB-DN•H0	FA 4556-•DN →	NA B112KP-DN•	FA 4840-•DN →	NA L112KD-DN•
FA 4112-KDM →	NA B110FB-DMKHO	FA 4556-KDM →	NA B112KP-DMK	FA 4840-KDM →	NA L112KD-DMK
FA 4113-•DN →	NA B110EE-DN•	FA 4557-•DN →	NA B112KH-DN•	FA 4850-•DN →	NA L112LE-DN•
FA 4113-KDM →	NA B110EE-DMK	FA 4557-KDM →	NA B112KH-DMK	FA 4850-KDM →	NA L112LE-DMK
FA 4115-•DN →	NA B110BB-DN•	FA 4569-•DN →	NA B112LH-DN•	FA 4851-•DN →	NA L112KE-DN•
FA 4115-KDM →	NA B110BB-DMK	FA 4569-KDM →	NA B112LH-DMK	FA 4851-KDM →	NA L112KE-DMK
FA 4117-•DN →	NA B110BB-DN•H0	FA 4601-•DN →	NA G110AB-DN•	FA 4852-•DN →	NA L112KF-DN•
FA 4117-KDM →	NA B110BB-DMKHO	FA 4601-KDM →	NA G110AB-DMK	FA 4852-KDM →	NA L112KF-DMK
FA 4120-•DN →	NA B110HB-DN•	FA 4602-•DN →	NA G110CP-DN•	FA 4854-•DN →	NA L112KG-DN•
FA 4120-KDM →	NA B110HB-DMK	FA 4602-KDM →	NA G110CP-DMK	FA 4854-KDM →	NA L112KG-DMK
FA 4125-•DN →	NA B110HE-DN•	FA 4608-•DN →	NA G110AE-DN•	FA 4855-•DN →	NA L112KP-DN•
FA 4125-KDM →	NA B110HE-DMK	FA 4608-KDM →	NA G110AE-DMK	FA 4855-KDM →	NA L112KP-DMK
FA 4130-•DN →	NA B112KA-DN•	FA 4610-•DN →	NA G110EB-DN•	FA 4856-•DN →	NA L112KP-DN•
FA 4130-KDM →	NA B112KA-DMK	FA 4610-KDM →	NA G110EB-DMK	FA 4856-KDM →	NA L112KP-DMK
FA 4131-•DN →	NA B112KC-DN•	FA 4611-•DN →	NA G110FB-DN•	FA 4857-•DN →	NA L112KH-DN•
FA 4131-KDM →	NA B112KC-DMK	FA 4611-KDM →	NA G110FB-DMK	FA 4857-KDM →	NA L112KH-DMK
FA 4133-•DN →	NA B112LB-DN•	FA 4612-•DN →	NA G110FB-DN•H0	FA 4869-•DN →	NA L112LH-DN•
FA 4133-KDM →	NA B112LB-DMK	FA 4612-KDM →	NA G110FB-DMKHO	FA 4869-KDM →	NA L112LH-DMK
FA 4134-•DN →	NA B112LL-DN•	FA 4613-•DN →	NA G110EE-DN•	FF 4101-•DN →	NF B110AB-DN•
FA 4134-KDM →	NA B112LL-DMK	FA 4613-KDM →	NA G110EE-DMK	FF 4101-•SN →	NF B110AB-DN•
FA 4140-•DN →	NA B112KD-DN•	FA 4615-•DN →	NA G110BB-DN•	FF 4101-KSM →	NF B110AB-SMK
FA 4140-KDM →	NA B112KD-DMK	FA 4615-KDM →	NA G110BB-DMK	FF 4101-KDM →	NF B110AB-DMK
FA 4150-•DN →	NA B112LE-DN•	FA 4617-•DN →	NA G110BB-DN•H0	FF 4102-•DN →	NF B110CP-DN•
FA 4150-KDM →	NA B112LE-DMK	FA 4617-KDM →	NA G110BB-DMKHO	FF 4102-•SN →	NF B110CP-DN•
FA 4151-•DN →	NA B112KE-DN•	FA 4630-•DN →	NA G112KA-DN•	FF 4102-KSM →	NF B110CP-SMK
FA 4151-KDM →	NA B112KE-DMK	FA 4630-KDM →	NA G112KA-DMK	FF 4102-KDM →	NF B110CP-DMK
FA 4152-•DN →	NA B112KF-DN•	FA 4631-•DN →	NA G112KC-DN•	FF 4108-•DN →	NF B110AE-DN•
FA 4152-KDM →	NA B112KF-DMK	FA 4631-KDM →	NA G112KC-DMK	FF 4108-•SN →	NF B110AE-DN•
FA 4154-•DN →	NA B112KG-DN•	FA 4633-•DN →	NA G112LB-DN•	FF 4108-KSM →	NF B110AE-SMK
FA 4154-KDM →	NA B112KG-DMK	FA 4633-KDM →	NA G112LB-DMK	FF 4108-KDM →	NF B110AE-DMK
FA 4155-•DN →	NA B112KP-DN•	FA 4634-•DN →	NA G112LL-DN•	FF 4110-•DN →	NF B110EB-DN•
FA 4155-KDM →	NA B112KP-DMK	FA 4634-KDM →	NA G112LL-DMK	FF 4110-•SN →	NF B110EB-DN•
FA 4156-•DN →	NA B112KP-DN•	FA 4640-•DN →	NA G112KD-DN•	FF 4110-KSM →	NF B110EB-SMK
FA 4156-KDM →	NA B112KP-DMK	FA 4640-KDM →	NA G112KD-DMK	FF 4110-KDM →	NF B110EB-DMK
FA 4157-•DN →	NA B112KH-DN•	FA 4650-•DN →	NA G112LE-DN•	FF 4111-•DN →	NF B110FB-DN•
FA 4157-KDM →	NA B112KH-DMK	FA 4650-KDM →	NA G112LE-DMK	FF 4111-•SN →	NF B110FB-DN•
FA 4169-•DN →	NA B112LH-DN•	FA 4651-•DN →	NA G112KE-DN•	FF 4111-KSM →	NF B110FB-SMK
FA 4169-KDM →	NA B112LH-DMK	FA 4651-KDM →	NA G112KE-DMK	FF 4111-KDM →	NF B110FB-DMK
FA 4501-•DN →	NA B110AB-DN•	FA 4652-•DN →	NA G112KF-DN•	FF 4112-•DN →	NF B110FB-DN•H0
FA 4501-KDM →	NA B110AB-DMK	FA 4652-KDM →	NA G112KF-DMK	FF 4112-•SN →	NF B110FB-DN•H0
FA 4502-•DN →	NA B110CP-DN•	FA 4654-•DN →	NA G112KG-DN•	FF 4112-KSM →	NF B110FB-SMKHO
FA 4502-KDM →	NA B110CP-DMK	FA 4654-KDM →	NA G112KG-DMK	FF 4112-KDM →	NF B110FB-DMKHO
FA 4508-•DN →	NA B110AE-DN•	FA 4655-•DN →	NA G112KP-DN•	FF 4113-•DN →	NF B110EE-DN•
FA 4508-KDM →	NA B110AE-DMK	FA 4655-KDM →	NA G112KP-DMK	FF 4113-•SN →	NF B110EE-DN•
FA 4510-•DN →	NA B110EB-DN•	FA 4656-•DN →	NA G112KP-DN•	FF 4113-KSM →	NF B110EE-SMK
FA 4510-KDM →	NA B110EB-DMK	FA 4656-KDM →	NA G112KP-DMK	FF 4113-KDM →	NF B110EE-DMK
FA 4511-•DN →	NA B110FB-DN•	FA 4657-•DN →	NA G112KH-DN•	FF 4115-•DN →	NF B110BB-DN•
FA 4511-KDM →	NA B110FB-DMK	FA 4657-KDM →	NA G112KH-DMK	FF 4115-•SN →	NF B110BB-DN•
FA 4512-•DN →	NA B110FB-DN•H0	FA 4669-•DN →	NA G112LH-DN•	FF 4115-KSM →	NF B110BB-SMK
FA 4512-KDM →	NA B110FB-DMKHO	FA 4669-KDM →	NA G112LH-DMK	FF 4115-KDM →	NF B110BB-DMK
FA 4513-•DN →	NA B110EE-DN•	FA 4801-•DN →	NA L110AB-DN•	FF 4117-•DN →	NF B110BB-DN•H0
FA 4513-KDM →	NA B110EE-DMK	FA 4801-KDM →	NA L110AB-DMK	FF 4117-•SN →	NF B110BB-DN•H0
FA 4515-•DN →	NA B110BB-DN•	FA 4802-•DN →	NA L110CP-DN•	FF 4117-KSM →	NF B110BB-SMKHO
FA 4515-KDM →	NA B110BB-DMK	FA 4802-KDM →	NA L110CP-DMK	FF 4117-KDM →	NF B110BB-DMKHO
FA 4517-•DN →	NA B110BB-DN•H0	FA 4808-•DN →	NA L110AE-DN•	FF 4120-•DN →	NF B110HB-DN•
FA 4517-KDM →	NA B110BB-DMKHO	FA 4808-KDM →	NA L110AE-DMK	FF 4120-•SN →	NF B110HB-DN•
FA 4520-•DN →	NA B110HB-DN•	FA 4810-•DN →	NA L110EB-DN•	FF 4120-KSM →	NF B110HB-SMK
FA 4520-KDM →	NA B110HB-DMK	FA 4810-KDM →	NA L110EB-DMK	FF 4120-KDM →	NF B110HB-DMK
FA 4525-•DN →	NA B110HE-DN•	FA 4811-•DN →	NA L110FB-DN•	FF 4125-•DN →	NF B110HE-DN•
FA 4525-KDM →	NA B110HE-DMK	FA 4811-KDM →	NA L110FB-DMK	FF 4125-•SN →	NF B110HE-DN•
FA 4530-•DN →	NA B112KA-DN•	FA 4812-•DN →	NA L110FB-DN•H0	FF 4125-KSM →	NF B110HE-SMK
FA 4530-KDM →	NA B112KA-DMK	FA 4812-KDM →	NA L110FB-DMKHO	FF 4125-KDM →	NF B110HE-DMK
FA 4531-•DN →	NA B112KC-DN•	FA 4813-•DN →	NA L110EE-DN•	FF 4130-•DN →	NF B112KA-DN•
FA 4531-KDM →	NA B112KC-DMK	FA 4813-KDM →	NA L110EE-DMK	FF 4130-•SN →	NF B112KA-DN•
FA 4533-•DN →	NA B112LB-DN•	FA 4815-•DN →	NA L110BB-DN•	FF 4130-KSM →	NF B112KA-SMK
FA 4533-KDM →	NA B112LB-DMK	FA 4815-KDM →	NA L110BB-DMK	FF 4130-KDM →	NF B112KA-DMK
FA 4534-•DN →	NA B112LL-DN•	FA 4817-•DN →	NA L110BB-DN•H0	FF 4131-•DN →	NF B112KC-DN•
FA 4534-KDM →	NA B112LL-DMK	FA 4817-KDM →	NA L110BB-DMKHO	FF 4131-•SN →	NF B112KC-DN•
FA 4540-•DN →	NA B112KD-DN•	FA 4820-•DN →	NA L110HB-DN•	FF 4131-KSM →	NF B112KC-SMK
FA 4540-KDM →	NA B112KD-DMK	FA 4820-KDM →	NA L110HB-DMK	FF 4131-KDM →	NF B112KC-DMK



Old Article	New Article	Old Article	New Article	Old Article	New Article
FF 4133-•DN →	NF B112LB-DN•	FF 4520-KDM →	NF B110HB-DMK	FF 4613-KSM →	NF G110EE-SMK
FF 4133-•SN →	NF B112LB-DN•	FF 4525-•DN →	NF B110HE-DN•	FF 4613-KDM →	NF G110EE-DMK
FF 4133-KSM →	NF B112LB-SMK	FF 4525-•SN →	NF B110HE-DN•	FF 4615-•DN →	NF G110BB-DN•
FF 4133-KDM →	NF B112LB-DMK	FF 4525-KSM →	NF B110HE-SMK	FF 4615-•SN →	NF G110BB-DN•
FF 4134-•DN →	NF B112LL-DN•	FF 4525-KDM →	NF B110HE-DMK	FF 4615-KSM →	NF G110BB-SMK
FF 4134-•SN →	NF B112LL-DN•	FF 4530-•DN →	NF B112KA-DN•	FF 4615-KDM →	NF G110BB-DMK
FF 4134-KSM →	NF B112LL-SMK	FF 4530-•SN →	NF B112KA-DN•	FF 4617-•DN →	NF G110BB-DN•H0
FF 4134-KDM →	NF B112LL-DMK	FF 4530-KSM →	NF B112KA-SMK	FF 4617-•SN →	NF G110BB-DN•H0
FF 4140-•DN →	NF B112KD-DN•	FF 4530-KDM →	NF B112KA-DMK	FF 4617-KSM →	NF G110BB-SMKH0
FF 4140-•SN →	NF B112KD-DN•	FF 4531-•DN →	NF B112KC-DN•	FF 4617-KDM →	NF G110BB-DMKH0
FF 4140-KSM →	NF B112KD-SMK	FF 4531-•SN →	NF B112KC-DN•	FF 4630-•DN →	NF G112KA-DN•
FF 4140-KDM →	NF B112KD-DMK	FF 4531-KSM →	NF B112KC-SMK	FF 4630-•SN →	NF G112KA-DN•
FF 4150-•DN →	NF B112LE-DN•	FF 4531-KDM →	NF B112KC-DMK	FF 4630-KDM →	NF G112KA-DMK
FF 4150-•SN →	NF B112LE-DN•	FF 4533-•DN →	NF B112LB-DN•	FF 4631-•DN →	NF G112KC-DN•
FF 4150-KSM →	NF B112LE-SMK	FF 4533-•SN →	NF B112LB-DN•	FF 4631-•SN →	NF G112KC-DN•
FF 4150-KDM →	NF B112LE-DMK	FF 4533-KSM →	NF B112LB-SMK	FF 4631-KSM →	NF G112KC-SMK
FF 4151-•DN →	NF B112KE-DN•	FF 4533-KDM →	NF B112LB-DMK	FF 4631-KDM →	NF G112KC-DMK
FF 4151-•SN →	NF B112KE-DN•	FF 4534-•DN →	NF B112LL-DN•	FF 4633-•DN →	NF G112LB-DN•
FF 4151-KSM →	NF B112KE-SMK	FF 4534-•SN →	NF B112LL-DN•	FF 4633-•SN →	NF G112LB-DN•
FF 4151-KDM →	NF B112KE-DMK	FF 4534-KSM →	NF B112LL-SMK	FF 4633-KSM →	NF G112LB-SMK
FF 4152-•DN →	NF B112KF-DN•	FF 4534-KDM →	NF B112LL-DMK	FF 4633-KDM →	NF G112LB-DMK
FF 4152-•SN →	NF B112KF-DN•	FF 4540-•DN →	NF B112KD-DN•	FF 4634-•DN →	NF G112LL-DN•
FF 4152-KSM →	NF B112KF-SMK	FF 4540-•SN →	NF B112KD-DN•	FF 4634-•SN →	NF G112LL-DN•
FF 4152-KDM →	NF B112KF-DMK	FF 4540-KSM →	NF B112KD-SMK	FF 4634-KSM →	NF G112LL-DMK
FF 4154-•DN →	NF B112KG-DN•	FF 4540-KDM →	NF B112KD-DMK	FF 4640-•DN →	NF G112KD-DN•
FF 4154-•SN →	NF B112KG-DN•	FF 4550-•DN →	NF B112LE-DN•	FF 4640-•SN →	NF G112KD-DN•
FF 4154-KSM →	NF B112KG-SMK	FF 4550-•SN →	NF B112LE-DN•	FF 4640-KSM →	NF G112KD-SMK
FF 4154-KDM →	NF B112KG-DMK	FF 4550-KDM →	NF B112LE-DMK	FF 4640-KDM →	NF G112KD-DMK
FF 4155-•DN →	NF B112KP-DN•	FF 4551-•DN →	NF B112KE-DN•	FF 4650-•DN →	NF G112LE-DN•
FF 4155-•SN →	NF B112KP-DN•	FF 4551-•SN →	NF B112KE-DN•	FF 4650-•SN →	NF G112LE-DN•
FF 4155-KSM →	NF B112KP-SMK	FF 4551-KDM →	NF B112KE-DMK	FF 4650-KSM →	NF G112LE-SMK
FF 4155-KDM →	NF B112KP-DMK	FF 4552-•DN →	NF B112KF-DN•	FF 4650-KDM →	NF G112LE-DMK
FF 4156-•DN →	NF B112KP-DN•	FF 4552-•SN →	NF B112KF-DN•	FF 4651-•DN →	NF G112KE-DN•
FF 4156-•SN →	NF B112KP-DN•	FF 4552-KSM →	NF B112KF-SMK	FF 4651-•SN →	NF G112KE-DN•
FF 4156-KSM →	NF B112KP-SMK	FF 4552-KDM →	NF B112KF-DMK	FF 4651-KSM →	NF G112KE-SMK
FF 4156-KDM →	NF B112KP-DMK	FF 4554-•DN →	NF B112KG-DN•	FF 4651-KDM →	NF G112KE-DMK
FF 4157-•DN →	NF B112KH-DN•	FF 4554-•SN →	NF B112KG-DN•	FF 4652-•DN →	NF G112KF-DN•
FF 4157-•SN →	NF B112KH-DN•	FF 4554-KSM →	NF B112KG-SMK	FF 4652-•SN →	NF G112KF-DN•
FF 4157-KSM →	NF B112KH-SMK	FF 4554-KDM →	NF B112KG-DMK	FF 4652-KSM →	NF G112KF-SMK
FF 4157-KDM →	NF B112KH-DMK	FF 4555-•DN →	NF B112KP-DN•	FF 4652-KDM →	NF G112KF-DMK
FF 4169-•DN →	NF B112LH-DN•	FF 4555-•SN →	NF B112KP-DN•	FF 4654-•DN →	NF G112KG-DN•
FF 4169-KSM →	NF B112LH-SMK	FF 4555-KDM →	NF B112KP-SMK	FF 4654-•SN →	NF G112KG-DN•
FF 4169-KDM →	NF B112LH-DMK	FF 4555-KDM →	NF B112KP-DMK	FF 4654-KSM →	NF G112KG-SMK
FF 4501-•DN →	NF B110AB-DN•	FF 4556-•DN →	NF B112KP-DN•	FF 4654-KDM →	NF G112KG-DMK
FF 4501-•SN →	NF B110AB-DN•	FF 4556-•SN →	NF B112KP-DN•	FF 4655-•DN →	NF G112KP-DN•
FF 4501-KSM →	NF B110AB-SMK	FF 4556-KSM →	NF B112KP-SMK	FF 4655-•SN →	NF G112KP-DN•
FF 4501-KDM →	NF B110AB-DMK	FF 4556-KDM →	NF B112KP-DMK	FF 4655-KSM →	NF G112KP-SMK
FF 4502-•DN →	NF B110CP-DN•	FF 4557-•DN →	NF B112KH-DN•	FF 4655-KDM →	NF G112KP-DMK
FF 4502-•SN →	NF B110CP-DN•	FF 4557-•SN →	NF B112KH-DN•	FF 4656-•DN →	NF G112KP-DN•
FF 4502-KSM →	NF B110CP-SMK	FF 4557-KSM →	NF B112KH-SMK	FF 4656-•SN →	NF G112KP-DN•
FF 4502-KDM →	NF B110CP-DMK	FF 4557-KDM →	NF B112KH-DMK	FF 4656-KDM →	NF G112KP-DMK
FF 4508-•DN →	NF B110AE-DN•	FF 4569-•DN →	NF B112LH-DN•	FF 4657-•DN →	NF G112KH-DN•
FF 4508-•SN →	NF B110AE-DN•	FF 4569-•SN →	NF B112LH-DN•	FF 4657-•SN →	NF G112KH-DN•
FF 4508-KSM →	NF B110AE-SMK	FF 4569-KSM →	NF B112LH-SMK	FF 4657-KSM →	NF G112KH-SMK
FF 4508-KDM →	NF B110AE-DMK	FF 4569-KDM →	NF B112LH-DMK	FF 4657-KDM →	NF G112KH-DMK
FF 4510-•DN →	NF B110EB-DN•	FF 4601-•DN →	NF G110AB-DN•	FF 4669-•DN →	NF G112LH-DN•
FF 4510-•SN →	NF B110EB-DN•	FF 4601-•SN →	NF G110AB-DN•	FF 4669-•SN →	NF G112LH-DN•
FF 4510-KSM →	NF B110EB-SMK	FF 4601-KSM →	NF G110AB-SMK	FF 4669-KSM →	NF G112LH-SMK
FF 4510-KDM →	NF B110EB-DMK	FF 4601-KDM →	NF G110AB-DMK	FF 4669-KDM →	NF G112LH-DMK
FF 4511-•DN →	NF B110FB-DN•	FF 4602-•DN →	NF G110CP-DN•	FF 4801-•DN →	NF L110AB-DN•
FF 4511-•SN →	NF B110FB-DN•	FF 4602-•SN →	NF G110CP-DN•	FF 4801-KSM →	NF L110AB-SMK
FF 4511-KSM →	NF B110FB-SMK	FF 4602-KSM →	NF G110CP-SMK	FF 4801-KDM →	NF L110AB-DMK
FF 4511-KDM →	NF B110FB-DMK	FF 4602-KDM →	NF G110CP-DMK	FF 4802-•DN →	NF L110CP-DN•
FF 4512-•DN →	NF B110FB-DN•H0	FF 4608-KDM →	NF G110AE-DMK	FF 4802-•SN →	NF L110CP-DN•
FF 4512-•SN →	NF B110FB-DN•H0	FF 4610-•DN →	NF G110EB-DN•	FF 4802-KDM →	NF L110CP-DMK
FF 4512-KSM →	NF B110FB-SMKH0	FF 4610-•SN →	NF G110EB-DN•	FF 4808-•DN →	NF L110AE-DN•
FF 4512-KDM →	NF B110FB-DMKH0	FF 4610-KSM →	NF G110EB-SMK	FF 4808-•SN →	NF L110AE-DN•
FF 4513-•DN →	NF B110EE-DN•	FF 4610-KDM →	NF G110EB-DMK	FF 4808-KDM →	NF L110AE-SMK
FF 4513-•SN →	NF B110EE-DN•	FF 4611-•DN →	NF G110FB-DN•	FF 4810-•DN →	NF L110AE-DMK
FF 4513-KSM →	NF B110EE-SMK	FF 4611-•SN →	NF G110FB-DN•	FF 4810-•SN →	NF L110EB-DN•
FF 4513-KDM →	NF B110EE-DMK	FF 4611-KSM →	NF G110FB-SMK	FF 4810-KSM →	NF L110EB-SMK
FF 4515-•DN →	NF B110BB-DN•	FF 4612-•DN →	NF G110FB-DN•H0	FF 4810-KDM →	NF L110EB-DMK
FF 4515-•SN →	NF B110BB-DN•	FF 4612-•SN →	NF G110FB-DN•H0	FF 4811-•DN →	NF L110FB-DN•
FF 4515-KSM →	NF B110BB-SMK	FF 4612-KSM →	NF G110FB-SMKH0	FF 4811-•SN →	NF L110FB-DN•
FF 4515-KDM →	NF B110BB-DMK	FF 4612-KDM →	NF G110FB-DMKH0	FF 4811-KSM →	NF L110FB-SMK
FF 4517-•DN →	NF B110BB-DN•H0	FF 4613-•DN →	NF G110EE-DN•	FF 4811-KDM →	NF L110FB-DMK
FF 4517-•SN →	NF B110BB-DN•H0	FF 4613-•SN →	NF G110EE-DN•	FF 4812-•DN →	NF L110FB-DN•H0
FF 4517-KSM →	NF B110BB-SMKH0				
FF 4517-KDM →	NF B110BB-DMKH0				
FF 4520-•DN →	NF B110HB-DN•				
FF 4520-•SN →	NF B110HB-DN•				
FF 4520-KSM →	NF B110HB-SMK				

Old Article	New Article	Old Article	New Article
FF 4812-•SN →	NF L110FB-DN•H0	FK ••••-W →	FK ••••-W3
FF 4812-KSM →	NF L110FB-SMKH0	FK ••••-W1 →	FK ••••-W3
FF 4812-KDM →	NF L110FB-DMKH0	FK •15-1 →	FK •15-R28
FF 4813-•DN →	NF L110EE-DN•	FK •15-1W3 →	FK •15-W3R28
FF 4813-•SN →	NF L110EE-DN•	FM ••••-W →	FM ••••-W3
FF 4813-KSM →	NF L110EE-SMK	FM ••••-W1 →	FM ••••-W3
FF 4813-KDM →	NF L110EE-DMK	FM •01-72 →	FM •F1-M2
FF 4815-•DN →	NF L110BB-DN•	FM •15 →	FM •15-R28
FF 4815-•SN →	NF L110BB-DN•	FM •15-1M2-EX7 →	FM •15-M2R28-EX7
FF 4815-KSM →	NF L110BB-SMK	FM •15-W3 →	FM •15-W3M2R28
FF 4815-KDM →	NF L110BB-DMK	FR ••••-W →	FR ••••-W3
FF 4817-•DN →	NF L110BB-DN•H0	FR ••••-W1 →	FR ••••-W3
FF 4817-•SN →	NF L110BB-DN•H0	FR •01-72 →	FR •F1-M2
FF 4817-KSM →	NF L110BB-SMKH0	FR •15-1 →	FR •15-R28
FF 4817-KDM →	NF L110BB-DMKH0	FR •15-1W3 →	FR •15-W3R28
FF 4820-•DN →	NF L110HB-DN•	FX ••••-W →	FX ••••-W3
FF 4820-•SN →	NF L110HB-DN•	FX ••••-W1 →	FX ••••-W3
FF 4820-KSM →	NF L110HB-SMK	FX •01-72 →	FX •F1-M2
FF 4820-KDM →	NF L110HB-DMK	FX •15-1 →	FX •15-R28
FF 4825-•DN →	NF L110HE-DN•	FX •15-1W3 →	FX •15-W3R28
FF 4825-•SN →	NF L110HE-DN•	FZ ••••-W →	FZ ••••-W3
FF 4825-KSM →	NF L110HE-SMK	FZ ••••-W1 →	FZ ••••-W3
FF 4825-KDM →	NF L110HE-DMK	FZ •01-72 →	FZ •F1-M2
FF 4830-•DN →	NF L112KA-DN•	FZ •15 →	FZ •15-R28
FF 4830-•SN →	NF L112KA-DN•	FZ •15-W3 →	FZ •15-W3R28
FF 4830-KSM →	NF L112KA-SMK	VF L••-1 →	VF L••-R24
FF 4830-KDM →	NF L112KA-DMK	VF L••-2 →	VF L••-R25
FF 4831-•DN →	NF L112KC-DN•	VF L••-3 →	VF L••-R26
FF 4831-•SN →	NF L112KC-DN•	VF L••-4 →	VF L••-R27
FF 4831-KSM →	NF L112KC-SMK	VF LE••-1 →	VF LE••-R24
FF 4831-KDM →	NF L112KC-DMK	VF LE••-2 →	VF LE••-R25
FF 4833-•DN →	NF L112LB-DN•	VF LE••-3 →	VF LE••-R26
FF 4833-•SN →	NF L112LB-DN•	VF LE••-4 →	VF LE••-R27
FF 4833-KSM →	NF L112LB-SMK	VF IL•••••• →	VF SL••••••
FF 4833-KDM →	NF L112LB-DMK	VF LE30	VN A00KA
FF 4834-•DN →	NF L112LL-DN•	VF LE30-R23	VN A00KA-R23
FF 4834-•SN →	NF L112LL-DN•	VF LE31	VN A00KB
FF 4834-KSM →	NF L112LL-SMK	VF LE31-R24	VN A00KB-R24
FF 4834-KDM →	NF L112LL-DMK	VF LE31-R25	VN A00KB-R25
FF 4840-•DN →	NF L112KD-DN•	VF LE31-R5	VN A00KB-R5
FF 4840-•SN →	NF L112KD-DN•	VF LE33	VN A00LB
FF 4840-KSM →	NF L112KD-SMK	VF LE34	VN A00LL
FF 4840-KDM →	NF L112KD-DMK	VF LE50	VN A00LE
FF 4850-•DN →	NF L112LE-DN•	VF LE51	VN A00KE
FF 4850-•SN →	NF L112LE-DN•	VF LE51-R24	VN A00KE-R24
FF 4850-KSM →	NF L112LE-SMK	VF LE51-R25	VN A00KE-R25
FF 4850-KDM →	NF L112LE-DMK	VF LE51-R26	VN A00KE-R26
FF 4851-•DN →	NF L112KE-DN•	VF LE51-R5	VN A00KE-R5
FF 4851-•SN →	NF L112KE-DN•	VF LE52	VN A00KF
FF 4851-KSM →	NF L112KE-SMK	VF LE52-R24	VN A00KF-R24
FF 4851-KDM →	NF L112KE-DMK	VF LE52-R25	VN A00KF-R25
FF 4852-•DN →	NF L112KF-DN•	VF LE52-R5	VN A00KF-R5
FF 4852-•SN →	NF L112KF-DN•	VF LE53	VN A00LP
FF 4852-KDM →	NF L112KF-DMK	VF LE54	VN A00KG
FF 4852-KSM →	NF L112KF-SMK	VF LE54-R24	VN A00KG-R24
FF 4854-•DN →	NF L112KG-DN•	VF LE54-R26	VN A00KG-R26
FF 4854-•SN →	NF L112KG-DN•	VF LE54-R5	VN A00KG-R5
FF 4854-KDM →	NF L112KG-DMK	VF LE55	VN A00KP
FF 4854-KSM →	NF L112KG-SMK	VF LE55-R24	VN A00KP-R24
FF 4855-•DN →	NF L112KP-DN•	VF LE55-R25	VN A00KP-R25
FF 4855-•SN →	NF L112KP-DN•	VF LE55-R26	VN A00KP-R26
FF 4855-KDM →	NF L112KP-DMK	VF LE55-R27	VN A00KP-R27
FF 4855-KSM →	NF L112KP-SMK	VF LE55-R5	VN A00KP-R5
FF 4856-•DN →	NF L112KP-DN•	VF LE56	VN A00KP
FF 4856-•SN →	NF L112KP-DN•	VF LE56-R24	VN A00KP-R24
FF 4856-KDM →	NF L112KP-DMK	VF LE56-R25	VN A00KP-R25
FF 4856-KSM →	NF L112KP-SMK	VF LE56-R26	VN A00KP-R26
FF 4857-•DN →	NF L112KH-DN•	VF LE56-R27	VN A00KP-R27
FF 4857-•SN →	NF L112KH-DN•	VF LE56-R5	VN A00KP-R5
FF 4857-KDM →	NF L112KH-DMK	VF LE57	VN A00KH
FF 4857-KSM →	NF L112KH-SMK	VF LE57-R24	VN A00KH-R24
FF 4869-•DN →	NF L112LH-DN•	VF LE69	VN A00LH
FF 4869-•SN →	NF L112LH-DN•		
FF 4869-KDM →	NF L112LH-DMK		
FF 4869-KSM →	NF L112LH-SMK		

# General terms and conditions of sale

## Order procedures:

Purchasing orders must always be sent in writing (e-mail). We reserve the right to not accept e-mail orders in case of missing characteristics necessary to correctly identify the sender or to not process them in case of virus infected attachments or attachments of dubious origin.

## Minimum billing amount:

Unless specifically agreed, the minimum billing amount is EUR 200 net (VAT excluded). For invoices of less than 200 Euro, a fee of 10 Euro will be charged if delivery is within the EU, or 30 Euro if delivery is outside the EU. Invoices are issued weekly.

## Prices:

The prices quoted in the price list do not include VAT, custom taxes or any other charges. Unless otherwise agreed, the prices quoted in the price list are not binding and may undergo changes without prior notice.

## Order quantities:

Some products are shipped in packs. The ordered quantities of these items must be multiples of the quantities contained in the packages.

## Order cancellation/changes:

Order changes might be accepted depending on the job order status. Changes or cancellation of special article orders will not be accepted. All terms and conditions stated in the order confirmation shall be deemed to be accepted without reservation after 2 working days from the date of the confirmation. What is stated in the customer's purchase order is not binding.

## Supply:

The supply includes only what is expressly stated in the order confirmation. As per article 1461 of the Italian Civil Code, we reserve the right to stop supply in case of changes in the customer's financial standing.

## Delivery:

The delivery is indicated in the order confirmation and reports the period in which the goods can be available at the factories of Pizzato Elettrica and not the date of arrival at the customer's premises. This date is an approximate value and cannot be used as a reason of the order non-fulfilment. A list of items in stock can be found at [www.pizzato.com](http://www.pizzato.com)

## Packaging:

Packaging is free. For more than six boxes pallets can be necessary for the transport.

## Shipment:

Unless expressly agreed between the parties, Pizzato Elettrica ships goods X works, in accordance with Incoterms® 2020 (published by the ICC). In the event that the customer requests transport against payment on the invoice, all parties agree that the goods always travel at the risk and peril of the customer. The customer must check that the forwarder delivers the number of boxes indicated in the delivery note, that the boxes are intact and that the weight corresponds to what is stated in the documents. In case of any inconsistencies, always accept the goods SUBJECT TO VERIFICATION, clearly specifying the type of damage. Any discrepancy or mistakes should be reported in writing within 8 days of receipt of the goods at [info@pizzato.com](mailto:info@pizzato.com).

## Warranty:

The warranty has a validity of 12 months starting from the shipping date of the material. The warranty does not cover improper use of the material, negligence or wrong installation/assembling. The warranty does not cover parts subjected to wear or products used beyond the technological limits described in the catalogue, or items that have not received the right maintenance. Pizzato Elettrica engages itself to repair and/or replace parts or the complete product for those elements that present evident manufacturing defects, provided that they are still covered by warranty. Pizzato Elettrica is only responsible for the value of the product and requests for compensation due to machine downtime, repairs or costs for direct or indirect damages resulting from product malfunctions will not be accepted, even if these occur during the warranty period. It is the responsibility of the manufacturer to evaluate the importance of the products used and the possible damage caused by their malfunction and to adopt the necessary technical measures to minimize consequences on machines also for personal safety purposes (redundancy systems, self-controlled systems, etc). The warranty will be subject to the customer's compliance with the payment terms. Any samples provided free of charge or bearing the phrase "SAMPLE" must be considered as purely demonstrative and are not covered by the guarantee.

## Products:

Products can be subjected to technical improvements in any moment without prior notice.

## Payment terms:

Payments should be settled within the terms agreed in the order confirmation. The payment method is always at the risk of the buyer, regardless of the means chosen. In case of delayed payment, Pizzato Elettrica reserves the right to stop the delivery of any current orders and charge interest at the rate envisaged by European Directive 2011/7/EU. Any technical or commercial complaints do not entitle the claimant to suspend the due payments.

## Returns:

Any products returned for any reason will not be accepted unless they are previously APPROVED and AUTHORISED in writing. Otherwise, Pizzato Elettrica reserves the right to reject the goods and return them "freight collect" at the expense of the buyer, in the same way by which they were forwarded. Returns have to be sent back within 3 months from the authorization date and no later. After this period, returns will not be accepted. The request to return goods will lead to their sales price being devalued and will be considered if relative to standard items and materials shipped no more than 12 months ago. The returned goods and the relative packaging must be intact and free from damage. The customer shall bear the packaging costs for returns.

## Ownership:

The delivered products remain property of Pizzato Elettrica until full settlement of the invoices.

## Proper Law:

The Court of Vicenza shall have jurisdiction in any disputes.

For the updated terms of sale, please consult the website [www.pizzato.it](http://www.pizzato.it)





















General Catalogue  
Detection



General Catalogue  
HMI



General Catalogue  
Safety



General Catalogue  
Lift



Website  
[www.pizzato.com](http://www.pizzato.com)



**Pizzato Elettrica s.r.l.** via Torino, 1 - 36063 Marostica (VI) Italy  
Phone: +39 0424 470 930  
E-mail: [info@pizzato.com](mailto:info@pizzato.com)  
Website: [www.pizzato.com](http://www.pizzato.com)

ZE GCP05A22-ENG

